

REVISONS		DATE	DWN	APVD
LOC	DIST	DESCRIPTION		
AG	REV PER ECO	15-018502	2-16-16	CT CD

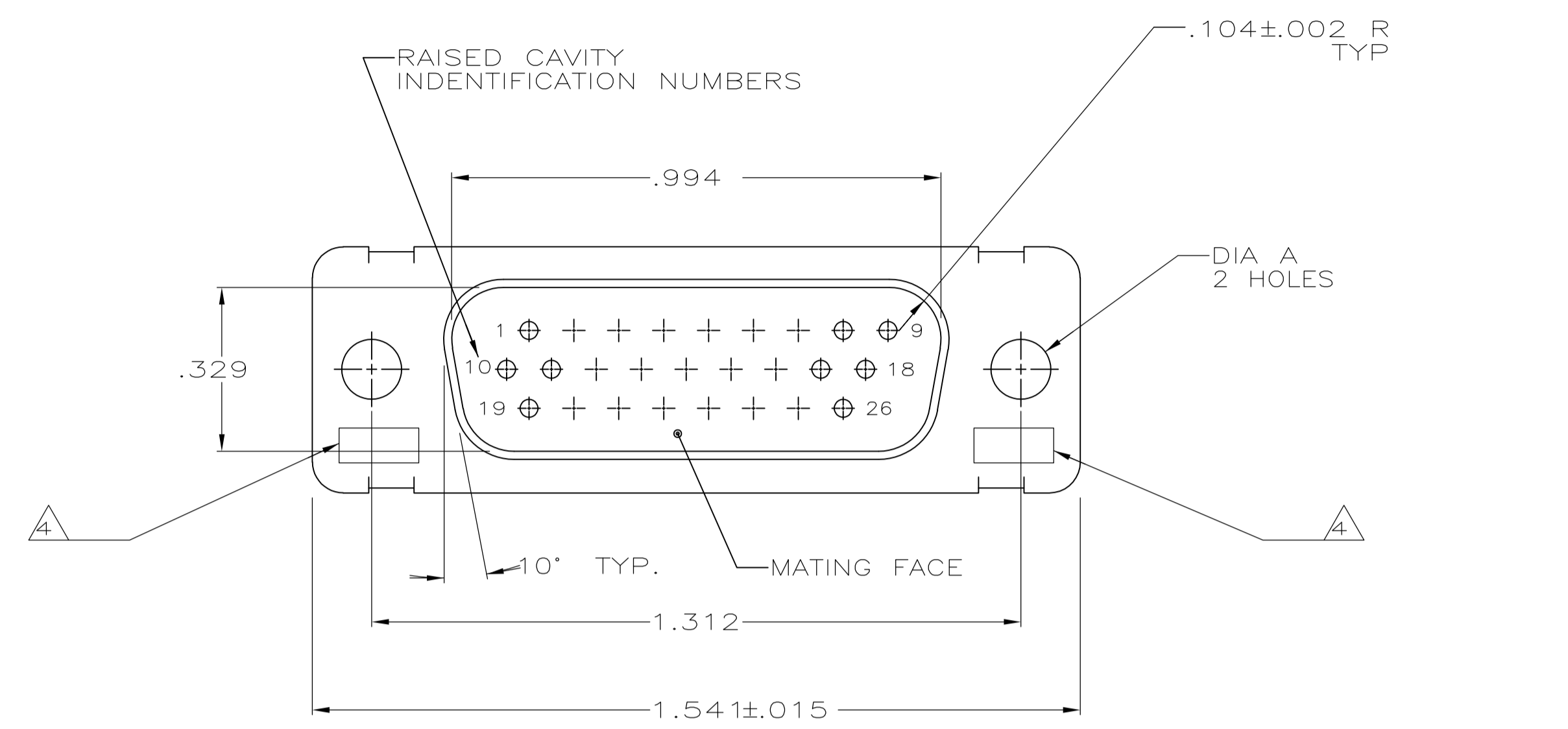

1. THIS PLUG WILL MATE WITH ANY RECEPTACLE CONNECTOR WITH THE SAME INSERT ARRANGEMENT AS DEFINED BY MS18274-2.
2. MAXIMUM WIRE INSULATION USED WITH THIS PLUG IS .054 DIA.
3. Be-Cu RETENTION CLIPS ARE INCLUDED IN INSERTS.
4. UL/CSA DESIGNATION STAMPED IN THIS AREA, OPTIONAL.
5. INSPECTION REQUIREMENTS PER R4383.
6. CONNECTOR SUPPLIED WITH 29 CONTACTS, TE PART NUMBER 204370-8.
7. CUSTOMER PART NUMBER MAY BE SPLIT BETWEEN FRONT AND REAR SHELLS, SAME SIDE.
8. 36 CONTACTS, TE PART NUMBER 204370-8, SUPPLIED WITH EACH CONNECTOR.
9. CONNECTOR LOADED WITH POSTED CONTACTS, INSPECTION REQUIREMENTS PER GENERAL ELECTRIC DOCUMENT 20025720.
10. RESTRICTED TO CAE ELECTRONICS ONLY.
11. THESE CONNECTORS ARE QUALIFIED TO GODDARD SPACE FLIGHT CENTER SPECIFICATION S-311-P-4.
12. CONNECTOR LOADED WITH POSTED CONTACTS.
13. PRELIMINARY PART NO, NOT RELEASED FOR PRODUCTION
14. CONNECTORS LOADED WITH POSTED CONTACTS. INSPECTION REQUIREMENTS PER LOCKHEED-MARTIN DOCUMENT 20131204

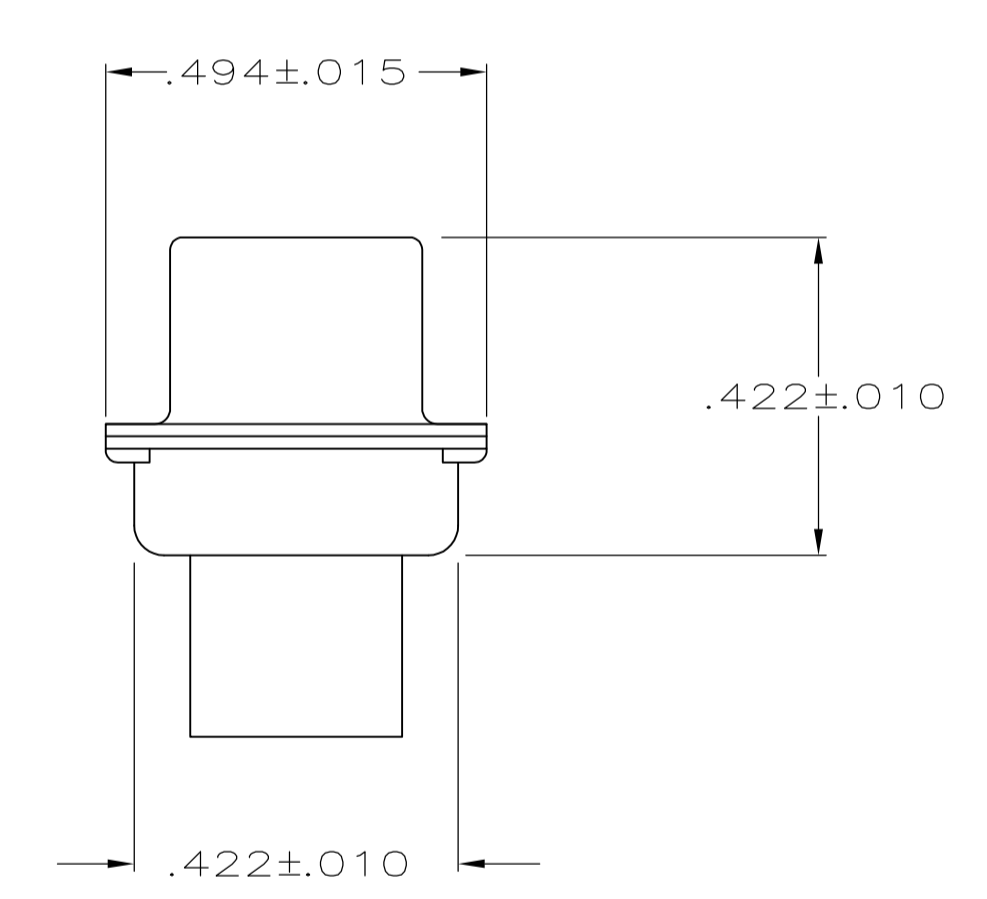
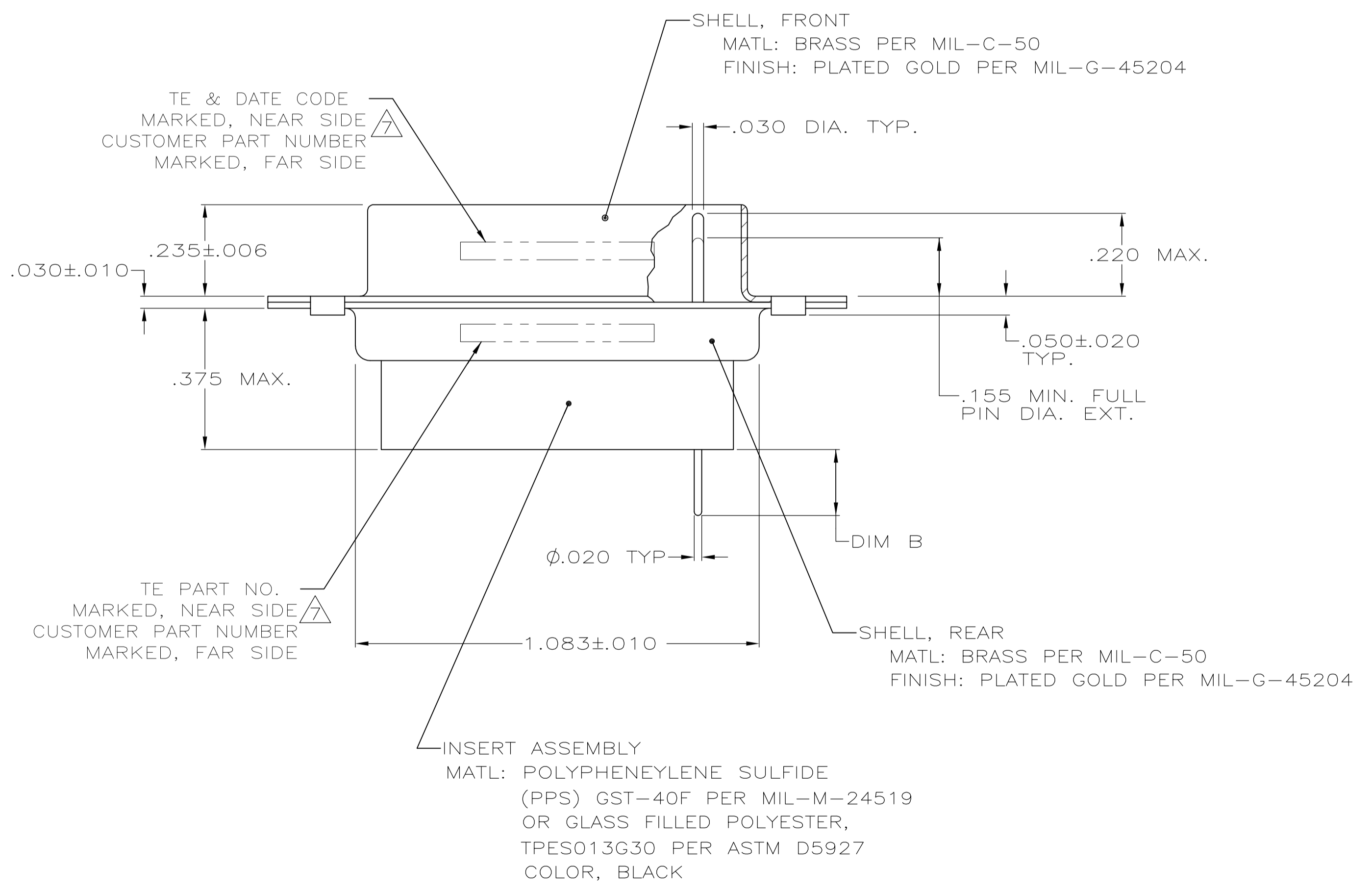

CONTACT P/N 204370-8  
GSFC G-08-P1  
(SUPPLIED WITH 206500-6 AND 206500-8 ONLY)

DIM B	REMARKS	DIA A	MARKED CUSTOMER P/N	MARKED AMP P/N	TE PART NUMBER
.150±.025	13, 14	.120	EJM023-105G08P032	1-206500-4	1-206500-4
.150±.025	13, 14	.120	20131204P2026P	1-206500-3	1-206500-3
.175±.025		.120	570566-8	1-206500-2	1-206500-2
.150±.025	11, 12, 10, 9, 8	.120	-	1-206500-1	1-206500-1
		.120	311P407-2P-B-12	206500-4	1-206500-0
		.120	20025720P2026P	206500-9	206500-9
		.120	3261113-9	206500-8	206500-8
		.154	1622251-004	206500-7	206500-7
		.120	R4383P26P	206500-6	206500-6
		.120	R4383P26P-2	206500-5	206500-5
		.120	311P407-2P-B-12	206500-4	206500-4
		.154		206500-3	206500-3
		.120	R9259P26P	206500-2	206500-2
		.154	311P407-2P-B-15	206500-1	206500-1

THIS DRAWING IS A CONTROLLED DOCUMENT.

DIMENSIONS: INCHES	TOLERANCES UNLESS OTHERWISE SPECIFIED:	0 PLC ± -	1 PLC ± -	2 PLC ± -	3 PLC ± .005	4 PLC ± -	ANGLES ± -
--------------------	--	-----------	-----------	-----------	--------------	-----------	------------

MATERIAL: SEE CALLOUTS. FINISH: SEE CALLOUTS.

APPROVED: MANJUNATH G. MANJUNATH, CHARLES THOMAS, G. DERRICK. DATE: 05JUN2015.

NAME: PLUG ASSEMBLY, AMPLITE, 26 POSITION, NONMAGNETIC, SIZE 2, SERIES 90.

SIZE: A1. CAGE CODE: 00779. DRAWING NO: 206500. WEIGHT: -. RESTRICTED TO: -.

CUSTOMER DRAWING. SCALE: 4:1. SHEET: 1 OF 1. REV: AG.