

- 1
- 2
- 3
- 4
- 5
- 6
- 7
- 8
- 9
- 10
- 11
- 12
- 13
- 14
- 15
- 16
- 17
- 18

**MATERIAL**

Aluminium.

**GRUB SCREWS**

AISI 304 stainless steel with hexagon socket.

**STANDARD EXECUTIONS**

- **MSM-B-ANB**: anodised aluminium, black colour.
- **MSM-B-MT**: natural aluminium, matte finish.

**KEY TO TABLE DIMENSIONS**

d = hole diameter for shaft tolerance h11.  
 d1= holes for clamping screws with threading as indicated in the table.  
 d2= clamping screws which can be replaced with clamping kit type GN 511 (see page 924).  
 f = fixing holes centre distance: it allows matching and fixing to magnetic bases MSM-RM (see page 915).

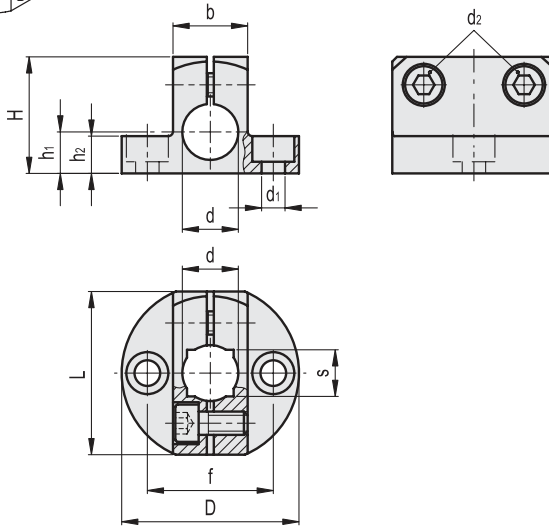
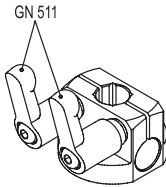

Conversion Table	
1 mm = 0.039 inch	
d	
mm	inch
8	0.31
10	0.39
12	0.47
15	0.59
16	0.63
20	0.79

**METRIC**

**MSM-B-ANB**

Code	Description	d	d1	d2	L	D	H	b	h1	h2	f	s	d2 Clamping kit	⚖️
500001	MSM-B-8-ANB	8	M4	M4	29	31.5	20	14	7	7	22	-	GN 511-M4-14	23
500005	MSM-B-10-ANB	10	M5	M5	35	38	24	16	8	8	27	8	GN 511-M5-16	36
500009	MSM-B-12-ANB	12	M5	M5	35	38	25	16	8	8	27	10	GN 511-M5-16	33
500013	MSM-B-15-ANB	15	M6	M6	41	45	30	20	10	10	32	12	GN 511-M 6-20	57
500017	MSM-B-16-ANB	16	M6	M6	41	45	31	20	10	10	32	-	GN 511-M6-20	57
500021	MSM-B-20-ANB	20	M6	M6	44	50	35	25	12.5	12.5	36	16	GN 511-M6-25	80

**METRIC**

**MSM-B-MT**

Code	Description	d	d1	d2	L	D	H	b	h1	h2	f	s	d2 Clamping kit	⚖️
500003	MSM-B-8-MT	8	M4	M4	29	31.5	20	14	7	7	22	-	GN 511-M4-14	23
500007	MSM-B-10-MT	10	M5	M5	35	38	24	16	8	8	27	8	GN 511-M5-16	36
500011	MSM-B-12-MT	12	M5	M5	35	38	25	16	8	8	27	10	GN 511-M5-16	33
500015	MSM-B-15-MT	15	M6	M6	41	45	30	20	10	10	32	12	GN 511-M6-20	57
500019	MSM-B-16-MT	16	M6	M6	41	45	31	20	10	10	32	-	GN 511-M6-20	57
500023	MSM-B-20-MT	20	M6	M6	44	50	35	25	12.5	12.5	36	16	GN 511-M6-25	76

Levelling feet and supports