

| PART NUMBER | REV | FIRST USED |
|-------------|-----|------------|
| 1385287 -1 | C | 854400-1 |
| 1385287 -2 | C | 565435-5 |
| 1385287 -3 | C | 354500-1 |

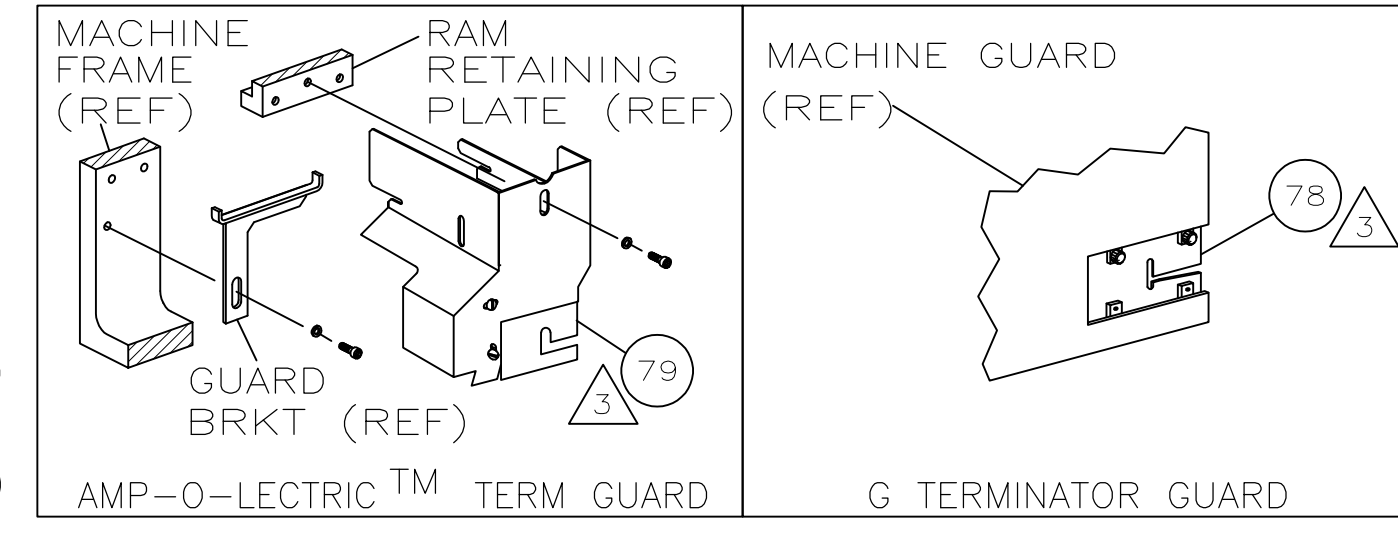

| TERMINAL NAME: .070 RCPT CONTACT | | CRIMPING DATA | | | |
|-------------------------------------|-----------|---------------|------------|----|--|
| PAD | LTR | CRIMP HEIGHT | WIRE SIZE | | |
| 184030 | | A | .067 ±.002 | 14 | |
| 184289 | | B | .057 ±.002 | 16 | |
| | | C | .049 ±.002 | 18 | |
| | | D | .046 ±.002 | 20 | |
| CRIMP | SIZE | TYPE | RANGE | | |
| WIRE | .090 | F | 20-14 | | |
| INSUL | .140 | SCROLL | .079-.106 | | |
| FEED | APPL INST | SET UP GAGE | LAYOUT | | |
| .386 | 408-8040 | 458637-1 | L1625 | | |
| TERM APPL SPEC 114-8004/6 | | | | | |
| WIRE STRIP LENGTH | | .155-.177 | | | |

| LOC | DIST | REVISIONS | | | |
|-----|------|---------------|--------|-----|------|
| F | LTR | DESCRIPTION | DATE | DRN | APPO |
| A | 66 | | | | |
| C | | ECR-07-014046 | 6-2007 | MY | GB |

| | | |
|----|---------------|----------------|
| -1 | LEADMAKER | MECH POST FEED |
| -2 | BENCH MODEL K | MECH PRE FEED |
| -3 | BENCH MODEL G | MECH PRE FEED |

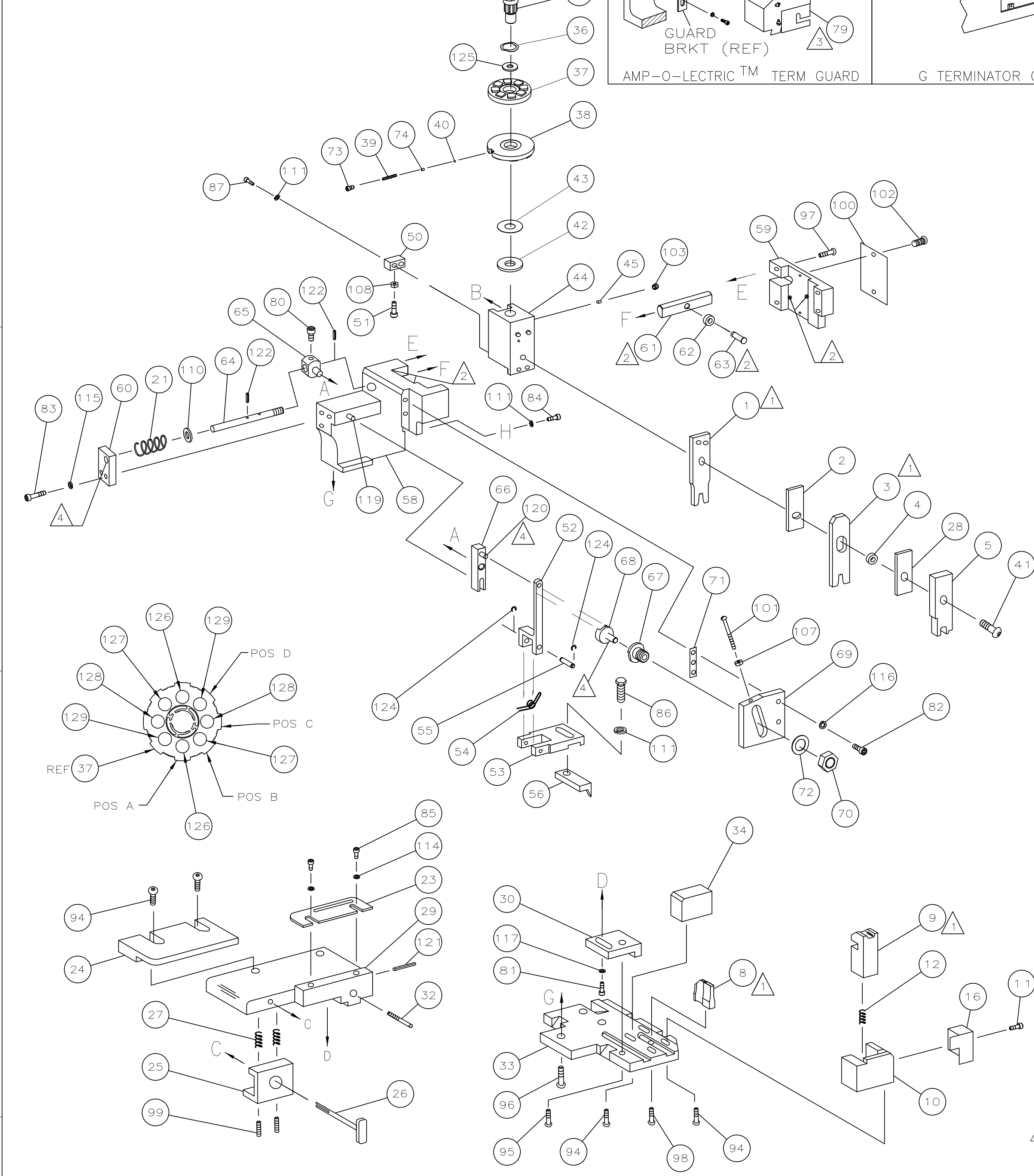

| | | | | | | |
|-------------------|-----|------------|-----|------------|---------------------------------|---------|
| 2 | 2 | 2 | - | 3-354779-2 | PIN, WIRE DISC (.3150)D | 129 |
| 2 | 2 | 2 | - | 2-354779-6 | PIN, WIRE DISC (.3120)C | 128 |
| 2 | 2 | 2 | - | 354779-9 | PIN, WIRE DISC (.3035)B | 127 |
| 2 | 2 | 2 | - | 8-354778-6 | PIN, WIRE DISC (.2925)A | 126 |
| 1 | 1 | 1 | - | 986950-1 | WASHER, FLAT PRECISION | 125 |
| REF | REF | REF | - | 21045-3 | RING,RET "C"(Φ.187)FD FING PIN | 124 |
| REF | REF | REF | - | | | 123 |
| REF | REF | REF | - | 5-21028-1 | PIN,SLT SPR(Φ.125x.50)ADJ ROD | 122 |
| 1 | 1 | 1 | - | 4-21028-0 | PIN,SLT SPR(Φ.093x.75)ST GDE PL | 121 |
| REF | REF | REF | - | 1-21030-1 | PIN,DOWEL(Φ.187x.50)LEVER | 120 |
| REF | REF | REF | - | 1-21030-6 | PIN,DOWEL(Φ.187x1.25)HOUSING | 119 |
| | | | | | | 118 |
| 1 | 1 | 1 | - | 21024-5 | WASHER, LOCK(#10)ADJ BLOCK | 117 |
| REF | REF | REF | - | 21024-5 | WASHER,LOCK(#10)ADJ PLATE | 116 |
| REF | REF | REF | - | 21024-5 | WASHER,LOCK(#10)FEED GDE ROD | 115 |
| 2 | 2 | 2 | - | 21024-2 | WASHER,LOCK(#4)FRONT STP GUIDE | 114 |
| | | | | | | 113 |
| | | | | | | 112 |
| 4 | 4 | 4 | - | 21024-4 | WASHER,LOCK(#8)STRIPPER | 111 |
| REF | REF | REF | - | 21899-4 | WASHER,FLAT(Φ5/16)SCREW ADJ | 110 |
| | | | | | | 109 |
| 1 | 1 | 1 | - | 21018-5 | NUT,HEX(NO.6)HOLDDOWN | 108 |
| REF | REF | REF | - | 21018-5 | NUT,HEX(6-32)FEED ADJ | 107 |
| | | | | | | 106 |
| | | | | | | 105 |
| | | | | | | 104 |
| 1 | 1 | 1 | - | 21009-2 | SCR,SKT SET(1/4-20x.25 LW)RAM | 103 |
| 2 | 2 | 2 | - | 21017-2 | SCR,DRIVE(#2x.19)ID PLATE | 102 |
| REF | REF | REF | - | 6-23715-5 | SCR,PAN HD(6-32x1.50)FEED ADJ | 101 |
| 1 | 1 | 1 | - | 461264-1 | PLATE, IDENTIFICATION | 100 |
| 2 | 2 | 2 | - | 5-21006-6 | SCR,SET(10-32x.75)DRAG | 99 |
| 1 | 1 | 1 | - | 22733-8 | SCR,BHC(8-32x.38 LW)ANVIL | 98 |
| REF | REF | REF | - | 2-21002-9 | SCR,BHC(10-32x.75)CAP | 97 |
| REF | REF | REF | - | 2-22733-8 | SCR,BHC(1/4-20x.62)HOUSING | 96 |
| REF | REF | REF | - | 2-21002-7 | SCR,BHC(10-32x.50)SG ADJ BLOCK | 95 |
| 6 | 6 | 6 | - | 2-21002-2 | SCR,BHC(8-32x.50)SHEAR | 94 |
| | | | | | | 93 |
| | | | | | | 92 |
| 1 | 1 | 1 | - | 1-21002-7 | SCR,BHC(6-32x.38)CAM | 91 |
| | | | | | | 90 |
| | | | | | | 89 |
| | | | | | | 88 |
| 2 | 2 | 2 | - | 2-21000-7 | SCR,SHC(8-32x.50)DEP-HOLD | 87 |
| 1 | 1 | 1 | - | 2-22603-0 | SCR,HEX HD(8-32x.31)FEED FINGER | 86 |
| 2 | 2 | 2 | - | 1-21000-3 | SCR,SHC(4-40x.25)F ST GUIDE | 85 |
| 1 | 1 | 1 | - | 2-21000-7 | SCR,SHC(8-32x.50)STRIPPER | 84 |
| REF | REF | REF | - | 3-21000-7 | SCR,SHC(10-32x.75)FEED ROD GD | 83 |
| REF | REF | REF | - | 3-21000-6 | SCR,SHC(10-32x.62)FD ADJ BLK | 82 |
| 1 | 1 | 1 | - | 3-21000-4 | SCR,SHC(10-32x.38)SG ADJ BL | 81 |
| REF | REF | REF | - | 3-21000-4 | SCR,SHC(10-32x.38)PIVOT BLK | 80 |
| - | REF | - | - | 455749-1 | GUARD, WINDOW | 79 |
| REF | - | - | - | 679532-1 | INSERT, GUARD | 78 |
| | | | | | | 77 |
| | | | | | | 76 |
| | | | | | | 75 |
| 1 | 1 | 1 | - | 690603-1 | SPRING, ASSIST | 74 |
| 1 | 1 | 1 | - | 23030-1 | SCR,SHC(6-32x.25 SL)INS DISC | 73 |
| REF | REF | REF | - | 458109-1 | WASHER, SPECIAL | 72 |
| REF | REF | REF | - | 690517-1 | SPACER | 71 |
| -3 | -2 | -1 | U/M | PART NO | DESCRIPTION | ITEM NO |
| QTY REQD PER ASSY | | PARTS LIST | | | ITEM NO | |

| REF | REF | REF | - | QTY | DESCRIPTION | ITEM NO |
|-------------------|-----|------------|-----|------------|-----------------------------|---------|
| REF | REF | REF | - | 22594-8 | NUT,HEX(1/2-20) | 70 |
| REF | REF | REF | - | 240628-1 | PLATE, ADJUSTMENT | 69 |
| REF | REF | REF | - | 240626-1 | SHAFT, PIVOT | 68 |
| REF | REF | REF | - | 240633-1 | BUSHING | 67 |
| REF | REF | REF | - | 455680-1 | LEVER, INTERMEDIATE | 66 |
| REF | REF | REF | - | 240629-1 | BLOCK, PIVOT | 65 |
| REF | REF | REF | - | 240632-2 | SCREW, ADJ FEED ROD | 64 |
| REF | REF | REF | - | 240659-3 | PIN, CAM ROLLER | 63 |
| REF | REF | REF | - | 240658-1 | ROLLER, CAM | 62 |
| REF | REF | REF | - | 454398-2 | ROD, FEED | 61 |
| REF | REF | REF | - | 454178-1 | GUIDE, FEED ROD | 60 |
| REF | REF | REF | - | 454220-1 | CAP, RAM | 59 |
| REF | REF | REF | - | 454485-1 | HOUSING | 58 |
| | | | | | | 57 |
| 1 | 1 | 1 | - | 458537-2 | PAWL, FEED | 56 |
| REF | REF | REF | - | 240624-1 | PIN, FEED FINGER | 55 |
| REF | REF | REF | - | 691499-1 | SPRING, FEED FINGER | 54 |
| REF | REF | REF | - | 690541-1 | HOLDER, FEED FINGER | 53 |
| REF | REF | REF | - | 455679-1 | LEVER, TERMINAL FEED ARM | 52 |
| 1 | 1 | 1 | - | 811242-2 | BUMPER, HOLDDOWN | 51 |
| 1 | 1 | 1 | - | 690753-1 | SPACER, TONKER | 50 |
| 1 | - | - | - | 690602-6 | CAM, PRE-FEED 1 5/8 ST | 49 |
| - | 1 | - | - | 690602-5 | CAM, PRE-FEED 1 1/8 ST | 48 |
| - | - | 1 | - | 690501-4 | CAM, POST-FEED 1 5/8 ST | 47 |
| 1 | 1 | 1 | - | 459456-1 | APPLICATOR, BASIC (SUBASSY) | 46 |
| 1 | 1 | 1 | - | 690191-1 | PLUG, NYLON | 45 |
| 1 | 1 | 1 | - | 455673-1 | RAM | 44 |
| 1 | 1 | 1 | - | 690125-1 | WASHER, LAMINATED | 43 |
| 1 | 1 | 1 | - | 690124-1 | WASHER, RAM | 42 |
| 1 | 1 | 1 | - | 7-21002-9 | BOLT, CRIMPER(5/16x1.00) | 41 |
| 1 | 1 | 1 | - | 23241-6 | BALL, STEEL | 40 |
| 1 | 1 | 1 | - | 690170-1 | SPRING, COMPRESSION | 39 |
| 1 | 1 | 1 | - | 1-690142-1 | DISC, INSULATION | 38 |
| 1 | 1 | 1 | - | 354777-1 | WIRE DISC, PLASTIC | 37 |
| 1 | 1 | 1 | - | 22480-5 | WASHER, SPRING | 36 |
| 1 | 1 | 1 | - | 690212-1 | POST, RAM | 35 |
| 1 | 1 | 1 | - | 690786-1 | SUPPORT, TERMINAL | 34 |
| REF | REF | REF | - | 455675-1 | PLATE, BASE | 33 |
| 1 | 1 | 1 | - | 690432-3 | SCREW, ADJUSTMENT | 32 |
| | | | | | | 31 |
| REF | REF | REF | - | 455689-1 | BLOCK, STRIP GUIDE ADJ | 30 |
| 1 | 1 | 1 | - | 455671-1 | PLATE, STRIP GUIDE | 29 |
| 1 | 1 | 1 | - | 455888-8 | SPACER, FRONT SHEAR DEP | 28 |
| 2 | 2 | 2 | - | 1-22284-0 | SPRING, DRAG | 27 |
| 1 | 1 | 1 | - | 690546-1 | LEVER, DRAG RELEASE | 26 |
| 1 | 1 | 1 | - | 240792-1 | DRAG, TERMINAL | 25 |
| 1 | 1 | 1 | - | 7-690504-6 | GUIDE, STRIP (REAR) | 24 |
| 1 | 1 | 1 | - | 690438-1 | GUIDE, STRIP (FRONT) | 23 |
| - | - | 1 | - | 690472-2 | STRIPPER | 22 |
| REF | REF | REF | - | 4-22284-9 | SPRING, FEED RETURN | 21 |
| | | | | | | 20 |
| 1 | 1 | - | - | 691353-1 | STRIPPER | 19 |
| | | | | | | 18 |
| | | | | | | 17 |
| 1 | 1 | 1 | - | 318563-1 | GUARD, CHIP (FRONT) | 16 |
| | | | | | | 15 |
| | | | | | | 14 |
| | | | | | | 13 |
| 1 | 1 | 1 | - | 3-22280-3 | SPRING, SHEAR | 12 |
| 1 | 1 | 1 | - | 690461-1 | STOP, SHEAR | 11 |
| 1 | 1 | 1 | - | 690459-1 | HOLDER, SHEAR (FRONT) | 10 |
| 1 | 1 | 1 | - | 1-454276-9 | SHEAR, FLOAT (FRONT) | 9 |
| 1 | 1 | 1 | - | 1-189717-8 | ANVIL | 8 |
| | | | | | | 7 |
| | | | | | | 6 |
| 1 | 1 | 1 | - | 2-455889-0 | DEPRESSOR, SHEAR (FRONT) | 5 |
| 1 | 1 | 1 | - | 1-238011-0 | SPACER, BLOCK CRIMPER | 4 |
| 1 | 1 | 1 | - | 1424367-2 | CRIMPER, INSULATION | 3 |
| 1 | 1 | 1 | - | 455888-7 | SPACER, CRIMPER | 2 |
| 1 | 1 | 1 | - | 3-456406-3 | CRIMPER, WIRE | 1 |
| -3 | -2 | -1 | U/M | PART NO | DESCRIPTION | ITEM NO |
| QTY REQD PER ASSY | | PARTS LIST | | | ITEM NO | |

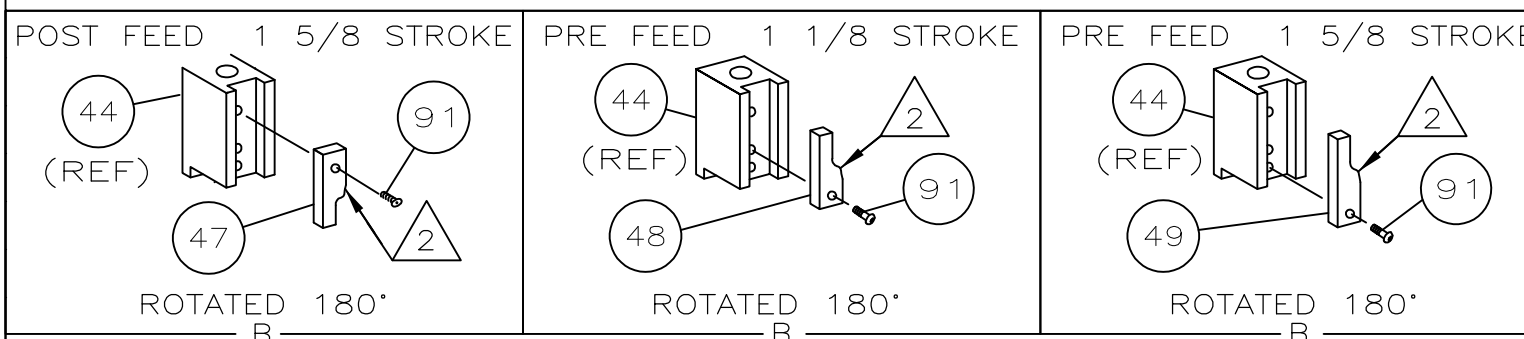

- 1. RECOMMENDED SPARE PARTS.
- 2. GREASE LIGHTLY.
- 3. GUARD MUST BE IN PLACE WHEN OPERATING APPLICATOR IN A BENCH MACHINE.
- 4. LUBRICATE DAILY USING NO. 20 MACHINE OIL.
- 5. ITEMS WITH QTY OF REF SPECIFIED (EXCEPT ITEMS 78 AND 79) ARE USED ON ITEM 46.
- 6. APPLICATOR APPLIES A SCROLL INSUL. CRIMP IN PLACE OF A SEAL. DISREGARD SECTIONS COVERING SEALS.

THIS DRAWING IS A CONTROLLED DOCUMENT.

| | | | |
|--------------------|----------------------------------------|---------------------|------------------|
| DIMENSIONS: INCHES | TOLERANCES UNLESS OTHERWISE SPECIFIED: | DRAWING NO: 1385287 | REV: C |
| MATERIAL | FINISH | SIZE: A1 | CAGE CODE: 00779 |
| CUSTOMER DRAWING | | SCALE: - | SHEET 1 OF 1 |

Tyco Electronics Corporation
Harrisburg, PA 17105-3608

NAME: SIDE FEED HDM APPLICATOR

APPROVED: T. ELBIN