

- NOTES:**
- HOUSING MAT'L.: POLYESTER, UNFILLED, 94V-0. COLOR: BLACK. TERMINAL MATERIAL: BRASS ALLOY
 - PLATINGS:
 - .000035/(.00090) MIN. REFLOWED MATTE TIN OVER .000020/(.00050) MIN. COPPER (PREPLATE) (FINISH IS BRIGHT IN APPEARANCE, THICKNESS AS APPLIED PRIOR TO REFLOW)
 - .000030/(.00076) MIN. SELECT GOLD AND .000100/(.00254) MIN. SELECT MATTE TIN OVER .000050/(.00127) MIN. NICKEL OVERALL.
 - .000100/(.00254) MIN. MATTE TIN OVER .000050/(.00127) MIN. NICKEL
 - PRODUCT SPECIFICATION PS-5556-003
 - PACKAGING SPECIFICATION: BULK PER PK-30069-001 TRAY PER 300690000-PK
 - PART IS DESIGNED FOR USE WITH #4 OR M3 SELF TAPPING SCREWS.
 - PART MATES WITH RECEPTACLE 30067-*
 - THIS PART CONFORMS TO CLASS 'B' REQUIREMENTS OF COSMETIC SPECIFICATION PS-45499-002.

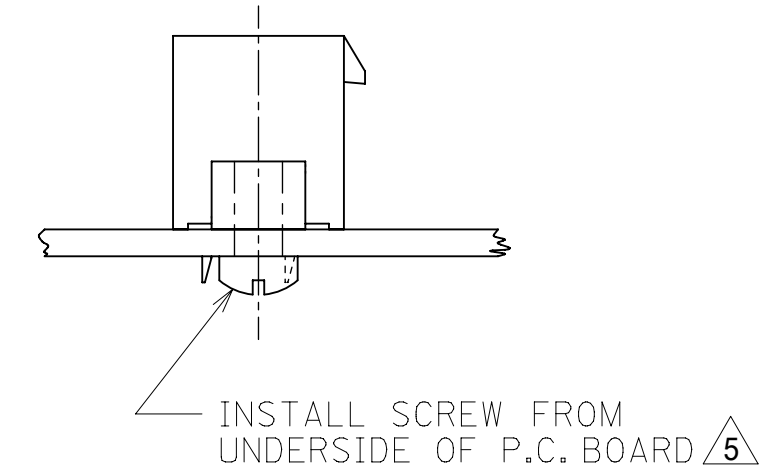

PCB LAYOUT FOR 2-16 CIRCUIT PARTS WITH FLANGES

RECOMMENDED INSTALLATION OF HEADER TO P.C. BOARD

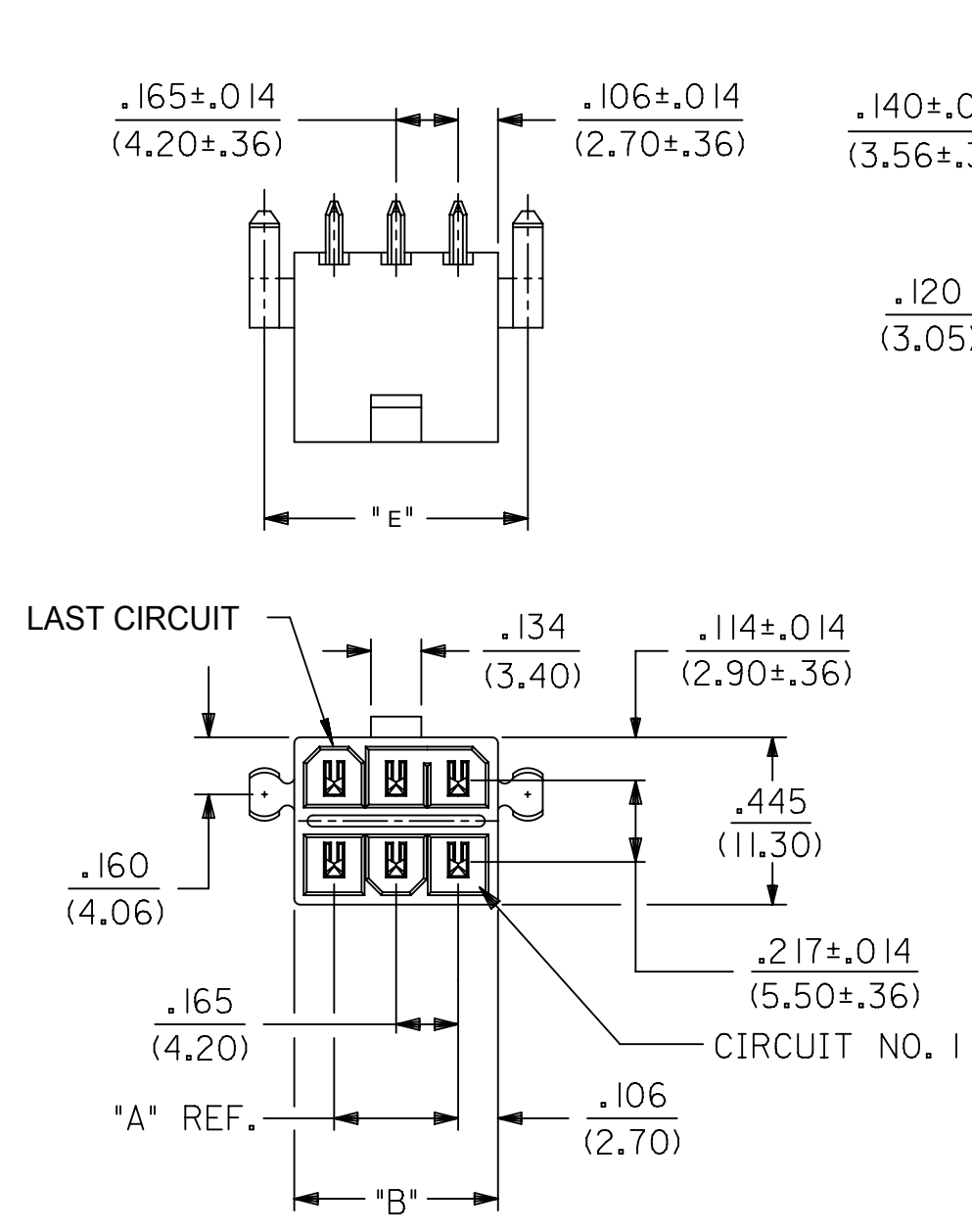

WITH PEGS

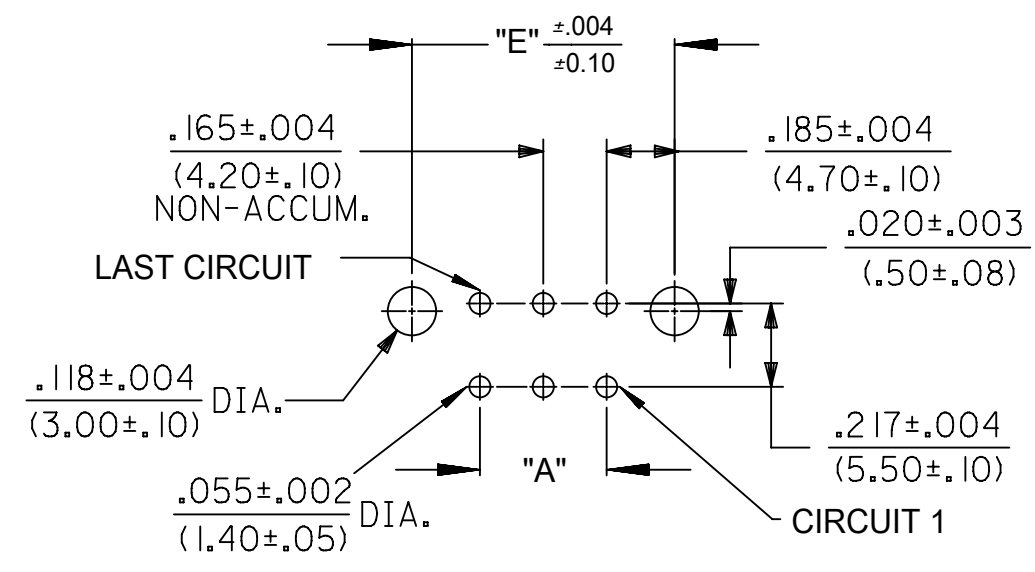
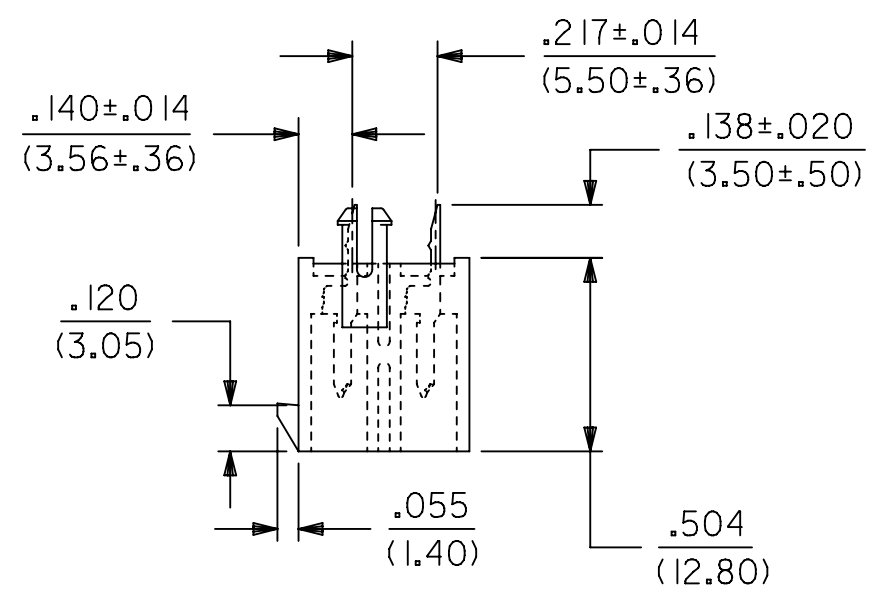

RECOMMENDED HOLE LAYOUT FOR .070/(1.78) MAX. THICK P.C. BOARD

PCB LAYOUT FOR 2-16 CIRCUIT PARTS

THIS DRAWING CONTAINS INFORMATION THAT IS PROPRIETARY TO MOLEX ELECTRONIC TECHNOLOGIES, LLC AND SHOULD NOT BE USED WITHOUT WRITTEN PERMISSION											
SYMBOLS		DIMENSION UNITS		SCALE		CURRENT REV DESC: INITIAL RELEASE					
△ = 0		IN/MM		2:1		EC NO: 173061 DRWN: AZAHIROVIC 2018/02/26 CHK'D: JBELL 2018/04/06 APPR: FSMITH 2018/04/13 INITIAL REVISION: DRWN: FJR 1991/19/09 APPR: FSMITH 2012/03/08 THIRD ANGLE PROJECTION DRAWING SERIES C-SIZE 30069					
▽ = 0		GENERAL TOLERANCES (UNLESS SPECIFIED)									
▽ = 0						4 PLACES ±		MM		INCH	
▽ = 0						3 PLACES ±		± 0.01			
▽ = 0						2 PLACES ±		0.25		± 0.014	
▽ = 0						1 PLACE ±		0.36		±	
⊠ = 0						0 PLACES ±		±			
■ = 0						ANGULAR TOL		± 0.5 °			
▽ = 0						DRAFT WHERE APPLICABLE MUST REMAIN WITHIN DIMENSIONS					
						DOCUMENT NUMBER		DOC TYPE		DOC PART	
						300690000-SD		PSD		000 A	
						MATERIAL NUMBER		CUSTOMER		SHEET NUMBER	
						SEE CHARTS		GENERAL MARKET		1 OF 3	

TIN-PLATED ASSEMBLIES WITH PEGS								GOLD-PLATED ASSEMBLIES WITH PEGS						
CKT. SIZE	ENG. NO.	EDP. NO.	DIM. "A"	DIM. "B"	DIM. "E"	DIM. "D"	PACKAGING	ENG. NO.	EDP. NO.	DIM. "A"	DIM. "B"	DIM. "E"	DIM. "D"	PACKAGING
2	A-30069-02C1	15-97-7023	----	<u>.213</u> (5.40)	<u>.370</u> (9.40)	----	BULK			----	<u>.213</u> (5.40)	<u>.370</u> (9.40)	----	BULK
4	A-30069-04C1	15-97-7043	<u>.165</u> (4.20)	<u>.378</u> (9.60)	<u>.535</u> (13.60)	----	BULK	A-30069-04C2	15-97-7045	<u>.165</u> (4.20)	<u>.378</u> (9.60)	<u>.535</u> (13.60)	----	BULK
6			<u>.331</u> (8.40)	<u>.543</u> (13.80)	<u>.701</u> (17.80)	----	BULK			<u>.331</u> (8.40)	<u>.543</u> (13.80)	<u>.701</u> (17.80)	----	BULK
8	A-30069-08C1	15-97-7083	<u>.496</u> (12.60)	<u>.709</u> (18.00)	<u>.866</u> (22.00)	----	BULK	A-30069-08C2	15-97-7085	<u>.496</u> (12.60)	<u>.709</u> (18.00)	<u>.866</u> (22.00)	----	BULK
10	A-30069-10C1	15-97-7103	<u>.661</u> (16.80)	<u>.874</u> (22.20)	<u>1.031</u> (26.20)	----	BULK	A-30069-10C2	15-97-7105	<u>.661</u> (16.80)	<u>.874</u> (22.20)	<u>1.031</u> (26.20)	----	TRAY
12	A-30069-12C1	15-97-7123	<u>.827</u> (21.00)	<u>1.039</u> (26.40)	<u>1.197</u> (30.40)	----	BULK	A-30069-12C2	15-97-7125	<u>.827</u> (21.00)	<u>1.039</u> (26.40)	<u>1.197</u> (30.40)	----	TRAY
14	A-30069-14C1	NOT TOOLED	<u>.992</u> (25.20)	<u>1.205</u> (30.60)	<u>1.362</u> (34.60)	----	BULK	A-30069-14C2	NOT TOOLED	<u>.992</u> (25.20)	<u>1.205</u> (30.60)	<u>1.362</u> (34.60)	----	TRAY
16	A-30069-16C1	NOT TOOLED	<u>1.157</u> (29.40)	<u>1.370</u> (34.80)	<u>1.528</u> (38.80)	----	BULK	A-30069-16C2	15-97-7165	<u>1.157</u> (29.40)	<u>1.370</u> (34.80)	<u>1.528</u> (38.80)	----	TRAY

LEGEND

A - 30069 - *** **

CIRCUIT SIZE
(2 - 16)

HOUSING STYLE
A = FLANGES
C = PEGS

PLATING
1 = TIN OVER COPPER
2 = GOLD OVER NICKEL
3 = MATTE TIN OVER NICKEL

TIN-PLATED ASSEMBLIES WITH FLANGES								GOLD-PLATED ASSEMBLIES WITH FLANGES						
CKT. SIZE	ENG. NO.	EDP. NO.	DIM. "A"	DIM. "B"	DIM. "C"	DIM. "D"	PACKAGING	ENG. NO.	EDP. NO.	DIM. "A"	DIM. "B"	DIM. "C"	DIM. "D"	PACKAGING
2	A-30069-02A1	15-97-7022	----	<u>.213</u> (5.40)	<u>.354</u> (9.00)	<u>.606</u> (15.40)	BULK	A-30069-02A2	15-97-7024	----	<u>.213</u> (5.40)	<u>.354</u> (9.00)	<u>.606</u> (15.40)	BULK
4	A-30069-04A1	15-97-7042	<u>.165</u> (4.20)	<u>.378</u> (9.60)	<u>.520</u> (13.20)	<u>.772</u> (19.60)	BULK	A-30069-04A2	15-97-7044	<u>.165</u> (4.20)	<u>.378</u> (9.60)	<u>.520</u> (13.20)	<u>.772</u> (19.60)	BULK
6	A-30069-06A1	15-97-7062	<u>.331</u> (8.40)	<u>.543</u> (13.80)	<u>.685</u> (17.40)	<u>.937</u> (23.80)	BULK	A-30069-06A2	15-97-7064	<u>.331</u> (8.40)	<u>.543</u> (13.80)	<u>.685</u> (17.40)	<u>.937</u> (23.80)	BULK
8	A-30069-08A1	15-97-7082	<u>.496</u> (12.60)	<u>.709</u> (18.00)	<u>.850</u> (21.60)	<u>1.102</u> (28.00)	BULK	A-30069-08A2	15-97-7084	<u>.496</u> (12.60)	<u>.709</u> (18.00)	<u>.850</u> (21.60)	<u>1.102</u> (28.00)	TRAY
10	A-30069-10A1	15-97-7102	<u>.661</u> (16.80)	<u>.874</u> (22.20)	<u>1.016</u> (25.80)	<u>1.268</u> (32.20)	BULK	A-30069-10A2	15-97-7104	<u>.661</u> (16.80)	<u>.874</u> (22.20)	<u>1.016</u> (25.80)	<u>1.268</u> (32.20)	BULK
12	A-30069-12A1	15-97-7122	<u>.827</u> (21.00)	<u>1.039</u> (26.40)	<u>1.181</u> (30.00)	<u>1.433</u> (36.40)	BULK	A-30069-12A2	15-97-7124	<u>.827</u> (21.00)	<u>1.039</u> (26.40)	<u>1.181</u> (30.00)	<u>1.433</u> (36.40)	BULK
14	A-30069-14A1	NOT TOOLED	<u>.992</u> (25.20)	<u>1.205</u> (30.60)	<u>1.346</u> (34.20)	<u>1.598</u> (40.60)	BULK	A-30069-14A2	NOT TOOLED	<u>.992</u> (25.20)	<u>1.205</u> (30.60)	<u>1.346</u> (34.20)	<u>1.598</u> (40.60)	BULK
16	A-30069-16A1	15-97-7162	<u>1.157</u> (29.40)	<u>1.370</u> (34.80)	<u>1.512</u> (38.40)	<u>1.764</u> (44.80)	BULK	A-30069-16A2	15-97-7164	<u>1.157</u> (29.40)	<u>1.370</u> (34.80)	<u>1.512</u> (38.40)	<u>1.764</u> (44.80)	BULK

SYMBOLS	THIS DRAWING CONTAINS INFORMATION THAT IS PROPRIETARY TO MOLEX ELECTRONIC TECHNOLOGIES, LLC AND SHOULD NOT BE USED WITHOUT WRITTEN PERMISSION									
	DIMENSION UNITS		SCALE		CURRENT REV DESC: INITIAL RELEASE					
	IN/MM		1:1		EC NO: 173061 DRWN: AZAHIROVIC 2018/02/26 CHK'D: JBELL 2018/04/06 APPR: FSMITH 2018/04/13 INITIAL REVISION: DRWN: FJR 1991/19/09 APPR: FSMITH 2012/03/08					
	GENERAL TOLERANCES (UNLESS SPECIFIED)									
▽ = 0	4 PLACES	±		MM	INCH	DOCUMENT NUMBER: 300690000-SD DOC TYPE: PSD DOC PART: 000 REVISION: A MATERIAL NUMBER: SEE CHARTS CUSTOMER: GENERAL MARKET SHEET NUMBER: 2 OF 3				
▽ = 0	3 PLACES	±		± 0.01						
▽ = 0	2 PLACES	±	0.25	± 0.014						
▽ = 0	1 PLACE	±	0.36	±						
⊠ = 0	0 PLACES	±				DRAWING: C-SIZE				
■ = 0	ANGULAR TOL		± 0.5 °	THIRD ANGLE PROJECTION		SERIES: 30069				
▽ = 0	DRAFT WHERE APPLICABLE MUST REMAIN WITHIN DIMENSIONS				DRAWING: C-SIZE		SERIES: 30069			

MATTE TIN-PLATED ASSEMBLIES WITH PEGS						
CKT. SIZE	MATERIAL NUMBER	DIM. "A"	DIM. "B"	DIM. "E"	DIM. "D"	PACKAGING
2	30069-0233	----	<u>.213</u> (5.40)	<u>.370</u> (9.40)	----	TRAY
4	30069-0433	<u>.165</u> (4.20)	<u>.378</u> (9.60)	<u>.535</u> (13.60)	----	TRAY
6		<u>.331</u> (8.40)	<u>.543</u> (13.80)	<u>.701</u> (17.80)	----	TRAY
8	30069-0833	<u>.496</u> (12.60)	<u>.709</u> (18.00)	<u>.866</u> (22.00)	----	TRAY
10	30069-1033	<u>.661</u> (16.80)	<u>.874</u> (22.20)	<u>1.031</u> (26.20)	----	TRAY
12	30069-1233	<u>.827</u> (21.00)	<u>1.039</u> (26.40)	<u>1.197</u> (30.40)	----	TRAY
14	NOT TOOLED	<u>.992</u> (25.20)	<u>1.205</u> (30.60)	<u>1.362</u> (34.60)	----	TRAY
16	30069-1633	<u>1.157</u> (29.40)	<u>1.370</u> (34.80)	<u>1.528</u> (38.80)	----	TRAY

MATTE TIN-PLATED ASSEMBLIES WITH FLANGES						
CKT. SIZE	MATERIAL NUMBER	DIM. "A"	DIM. "B"	DIM. "C"	DIM. "D"	PACKAGING
2	30069-0213	----	<u>.213</u> (5.40)	<u>.354</u> (9.00)	<u>.606</u> (15.40)	TRAY
4	30069-0413	<u>.165</u> (4.20)	<u>.378</u> (9.60)	<u>.520</u> (13.20)	<u>.772</u> (19.60)	TRAY
6	30069-0613	<u>.331</u> (8.40)	<u>.543</u> (13.80)	<u>.685</u> (17.40)	<u>.937</u> (23.80)	TRAY
8	30069-0813	<u>.496</u> (12.60)	<u>.709</u> (18.00)	<u>.850</u> (21.60)	<u>1.102</u> (28.00)	TRAY
10	30069-1013	<u>.661</u> (16.80)	<u>.874</u> (22.20)	<u>1.016</u> (25.80)	<u>1.268</u> (32.20)	TRAY
12	30069-1213	<u>.827</u> (21.00)	<u>1.039</u> (26.40)	<u>1.181</u> (30.00)	<u>1.433</u> (36.40)	TRAY
14	NOT TOOLED	<u>.992</u> (25.20)	<u>1.205</u> (30.60)	<u>1.346</u> (34.20)	<u>1.598</u> (40.60)	TRAY
16	30069-1613	<u>1.157</u> (29.40)	<u>1.370</u> (34.80)	<u>1.512</u> (38.40)	<u>1.764</u> (44.80)	TRAY

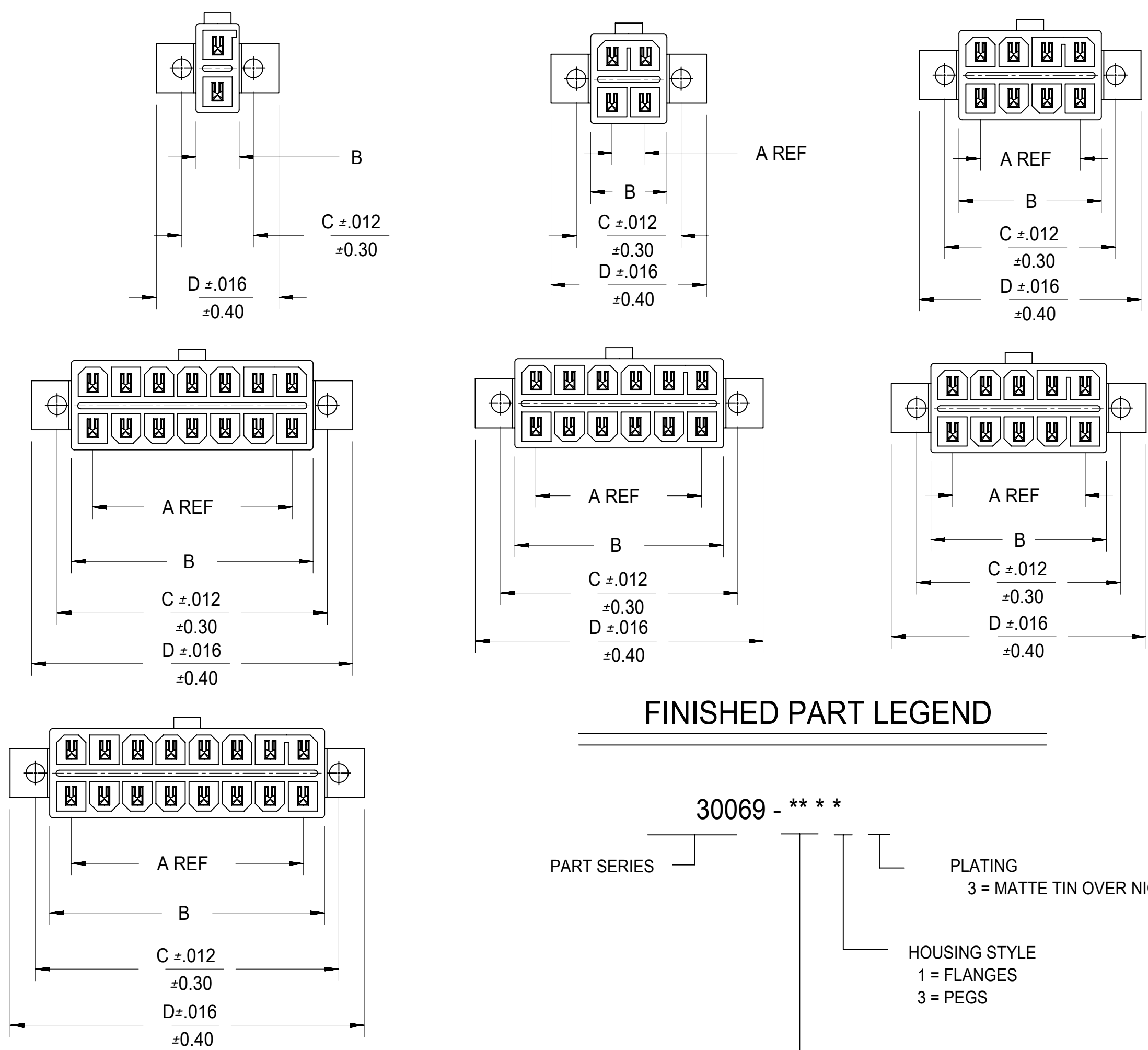

SYMBOLS				THIS DRAWING CONTAINS INFORMATION THAT IS PROPRIETARY TO MOLEX ELECTRONIC TECHNOLOGIES, LLC AND SHOULD NOT BE USED WITHOUT WRITTEN PERMISSION			
▽ = 0	▽ = 0	▽ = 0	▽ = 0	IN/MM	SCALE	CURRENT REV DESC: INITIAL RELEASE	
▽ = 0	▽ = 0	▽ = 0	▽ = 0	1:1		EC NO: 173061	
▽ = 0	▽ = 0	▽ = 0	▽ = 0	GENERAL TOLERANCES (UNLESS SPECIFIED)		DRWN: AZAHIROVIC	2018/02/26
▽ = 0	▽ = 0	▽ = 0	▽ = 0	MM	INCH	CHK'D: JBELL	2018/04/06
▽ = 0	▽ = 0	▽ = 0	▽ = 0	4 PLACES ±	±	APPR: FSMITH	2018/04/13
▽ = 0	▽ = 0	▽ = 0	▽ = 0	3 PLACES ±	± 0.01	INITIAL REVISION:	
▽ = 0	▽ = 0	▽ = 0	▽ = 0	2 PLACES ±	± 0.25 ± 0.014	DRWN: FJR	1991/19/09
▽ = 0	▽ = 0	▽ = 0	▽ = 0	1 PLACE ±	± 0.36 ±	APPR: FSMITH	2012/03/08
▽ = 0	▽ = 0	▽ = 0	▽ = 0	0 PLACES ±	±	DRAWING SERIES	
▽ = 0	▽ = 0	▽ = 0	▽ = 0	ANGULAR TOL ±	± 0.5 °	C-SIZE	30069
▽ = 0	▽ = 0	▽ = 0	▽ = 0	DRAFT WHERE APPLICABLE MUST REMAIN WITHIN DIMENSIONS		MATERIAL NUMBER CUSTOMER SHEET NUMBER	
▽ = 0	▽ = 0	▽ = 0	▽ = 0			SEE CHARTS	GENERAL MARKET 3 OF 3

molex

MINI-FIT T.P.A.
VERTICAL HEADER ASSEMBLY

PRODUCT CUSTOMER DRAWING

DOCUMENT NUMBER 300690000-SD DOC TYPE PSD DOC PART 000 REVISION A

SEE CHARTS GENERAL MARKET 3 OF 3