

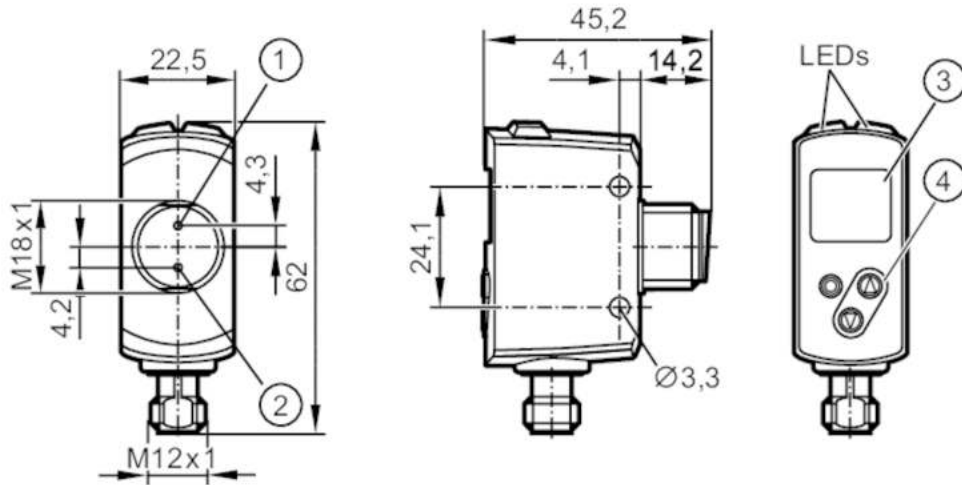

Photoelectric distance sensor

OGDLFPKG/IO-LINK/US



- 1 receiving element
- 2 transmitting element
- 3 alphanumeric display , 3-digit
- 4 programming buttons



Product characteristics

Type of light	red light
Laser protection class	1
Housing	rectangular with M18 thread

Application

Application	[m]	0.03...1.5
-------------	-----	------------

Electrical data

Operating voltage	[V]	10...30 DC; ("supply class 2" to cULus)
Current consumption	[mA]	< 75; (24 V)
Protection class		III
Reverse polarity protection		yes
Type of light		red light
Wave length	[nm]	650
Typ. lifetime	[h]	50000

Outputs

Electrical design		PNP
Output function		2 x normally open, 2 x normally closed; (parameterisable)
Permanent current rating of switching output DC	[mA]	100; (per output)
Type of short-circuit protection		pulsed
Overload protection		yes

Detection zone

Max. light spot width	[mm]	5
Max. light spot height	[mm]	5
Light spot dimensions refer to		at maximum range



Photoelectric distance sensor

OGDLFPKG/IO-LINK/US

Background suppression	[m]	0.03...20
------------------------	-----	-----------

Measuring/setting range

Measuring range	[m]	0.025...1.5
Sampling rate	[Hz]	< 33

Interfaces

Communication interface	IO-Link	
Transmission type	COM2 (38,4 kBaud)	
IO-Link revision	1.1	
SDCI standard	IEC 61131-9	
Profiles	Smart Sensor: Sensor Identification; Binary Data Channel; Process Value; Sensor Diagnosis	
SIO mode	yes	
Required master port type	A	
Process data analogue	2	
Process data binary	2	
Min. process cycle time	[ms]	6
Supported DeviceIDs	Type of operation	DeviceID
	Default	925

Operating conditions

Ambient temperature	[°C]	-25...60
Note on ambient temperature	In ambient temperatures < -10 °C a warm-up time is necessary.	
	Laser is off.	
Storage temperature	[°C]	-30...80
Protection	IP 65; IP 67	

Tests / approvals

EMC	EN 60947-5-2	
Laser protection class	1	
Notes on laser protection	Caution:	laser light
	laser class:	1
		EN / IEC60825-1:2007
		EN / IEC60825-1:2014
	Complies with 21 CFR 1040 except for deviations pursuant to Laser Notice No. 50, dated June 2007.	
MTTF	[years]	172

Mechanical data

Weight	[g]	205.5
Housing	rectangular with M18 thread	
Dimensions	[mm]	61.7 x 22.5 x 45.2
Thread designation	M18 x 1	
Materials	housing: stainless steel (1.4404 / 316L); PPSU; ABS; PMMA; PBT / PC; EPDM; front pane: glass	
Lens alignment	side lens	

OGD580



Photoelectric distance sensor

OGDLFPKG/IO-LINK/US

Displays / operating elements

Display	switching status	2 x LED, yellow 1 x alphanumeric display, 3-digit
---------	------------------	--

Accessories

Items supplied	lock nuts: 2
----------------	--------------

Remarks

Pack quantity	1 pcs.
---------------	--------

Electrical connection

Connector: 1 x M12; coding: A

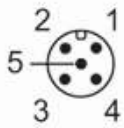

Connection

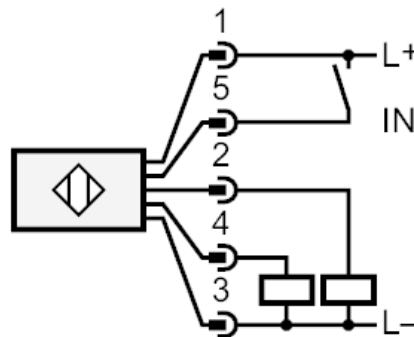

- 2: OUT2: switching output
- 4: OUT1: switching output or IO-Link
- 5: IN1: Laser On/ Off

OGD580



Photoelectric distance sensor

OGDLFPKG/IO-LINK/US

Other data		
Parameter	Setting range	Factory setting
Uni	cm, inch	cm
OU1	Hno, Hnc, Fno, Fnc, OFF	Hno
SP1 [cm]	3...150	150
nP1 [cm]	3...150	20
FSP1 [cm]	3...150	25
OU2	Hno, Hnc, Fno, Fnc, OFF	Hno
SP2 [cm]	3...150	3
nP2 [cm]	3...150	30
FP2 [cm]	3...150	35
dS1 [s]	0...0.1...5	0
dr1 [s]	0...0.1...5	0
dS2 [s]	0...0.1...5	0
dr2 [s]	0...0.1...5	0
dFo [s]	0...0.1...5	0.1
dIS	ON / OFF	ON

Repeatability: 6 σ

	repeatability of the measured values	
distance	white (90 % remission)	black (6 %...90 % remission)
25 mm	8.0 mm	15.0 mm
750 mm	8.0 mm	15.0 mm
1500 mm	20.0 mm	60.0 mm

The values apply at

Extraneous light on the object	< 10 klx
constant ambient conditions	23 °C / 960 hPa
minimum power-on time in minutes	15



Photoelectric distance sensor

OGDLFPKG/IO-LINK/US

Diagrams and graphs

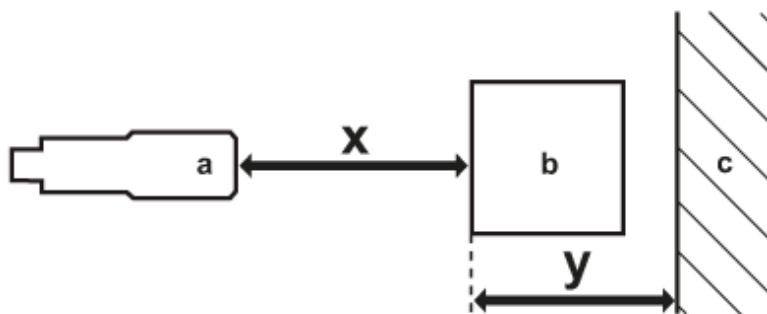

- a: sensor
- b: object
- c: background
- x: distance sensor/object [mm]
- y: min. distance object/background [mm]

hysteresis curve for distance measurement

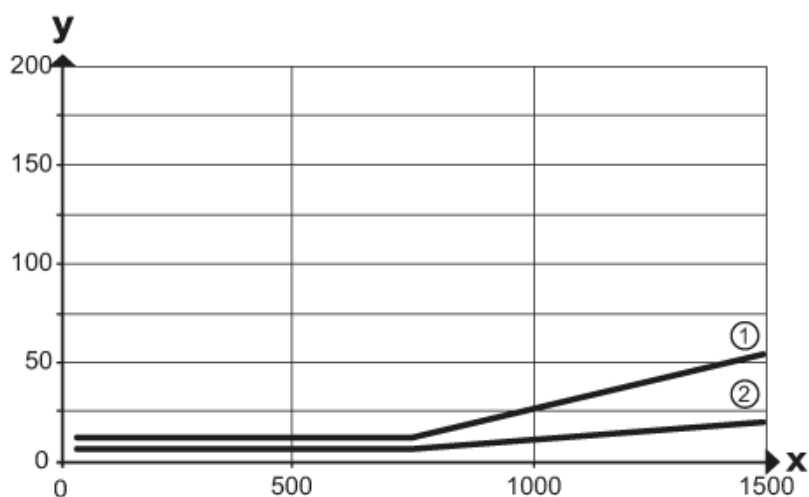

- x: distance sensor/object [mm]
- y: min. distance object/background [mm]
- 1 = background (black 6 % remission)
- 2 = Hintergrund_weiss_90_Remission