

LOC		DIST		REVISIONS			
P	LTR	DESCRIPTION	DATE	DMN	APVD		
E	REV PER ECO	10-009372	6-22-10	CT	DM		

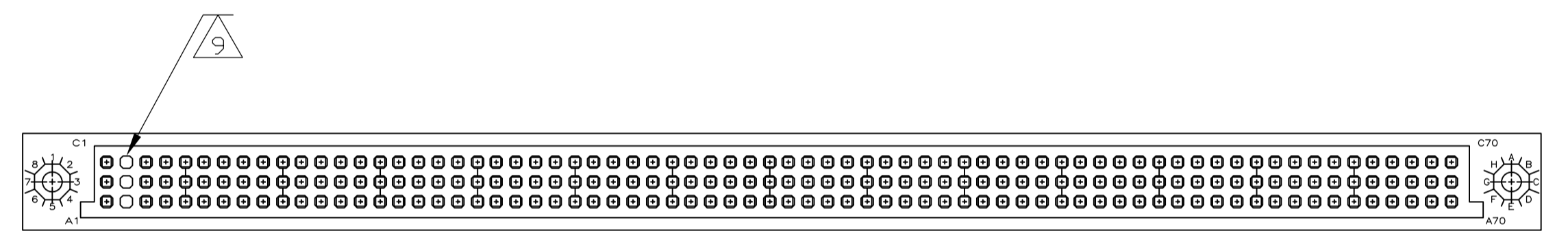

1996169-1

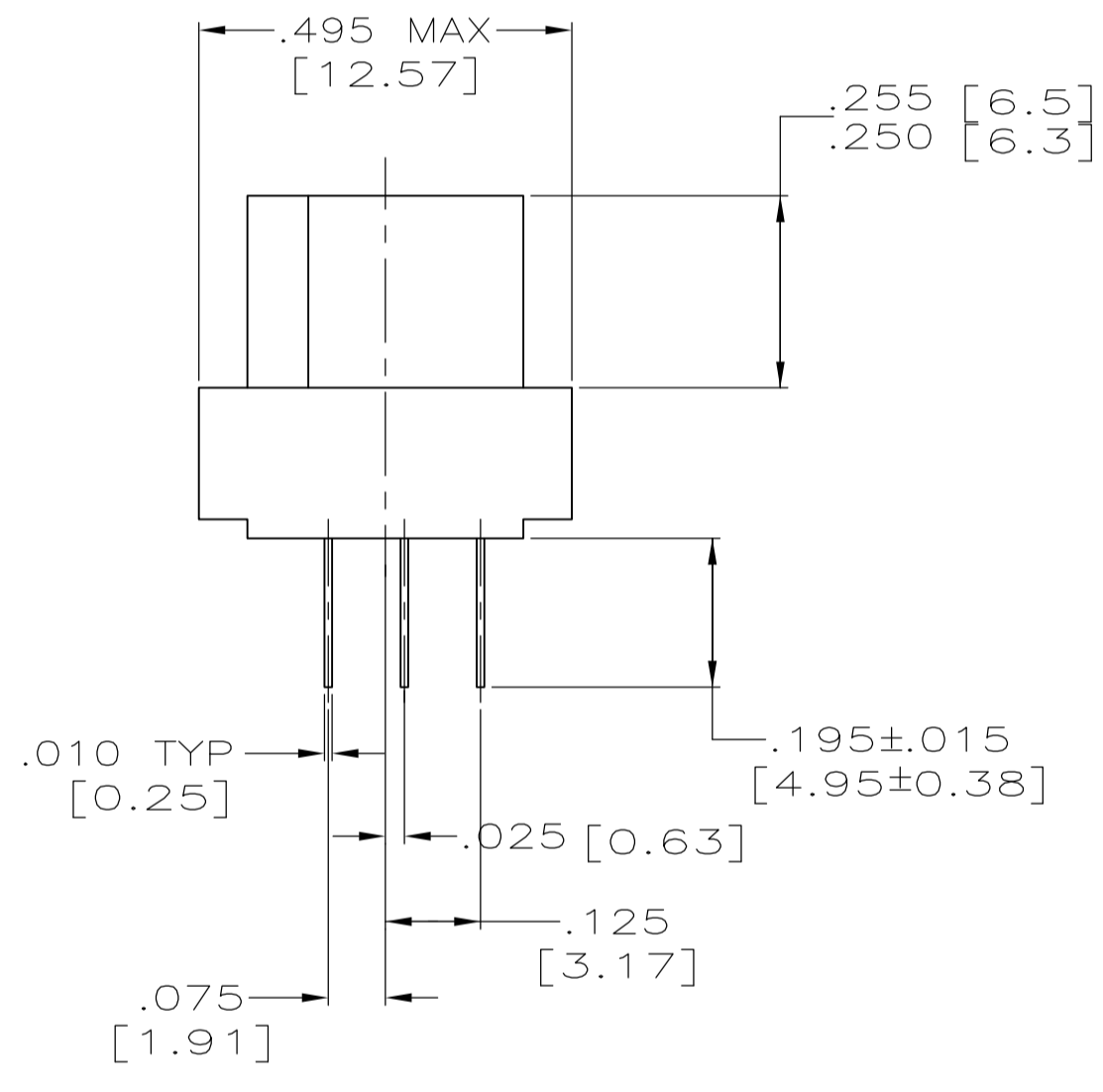
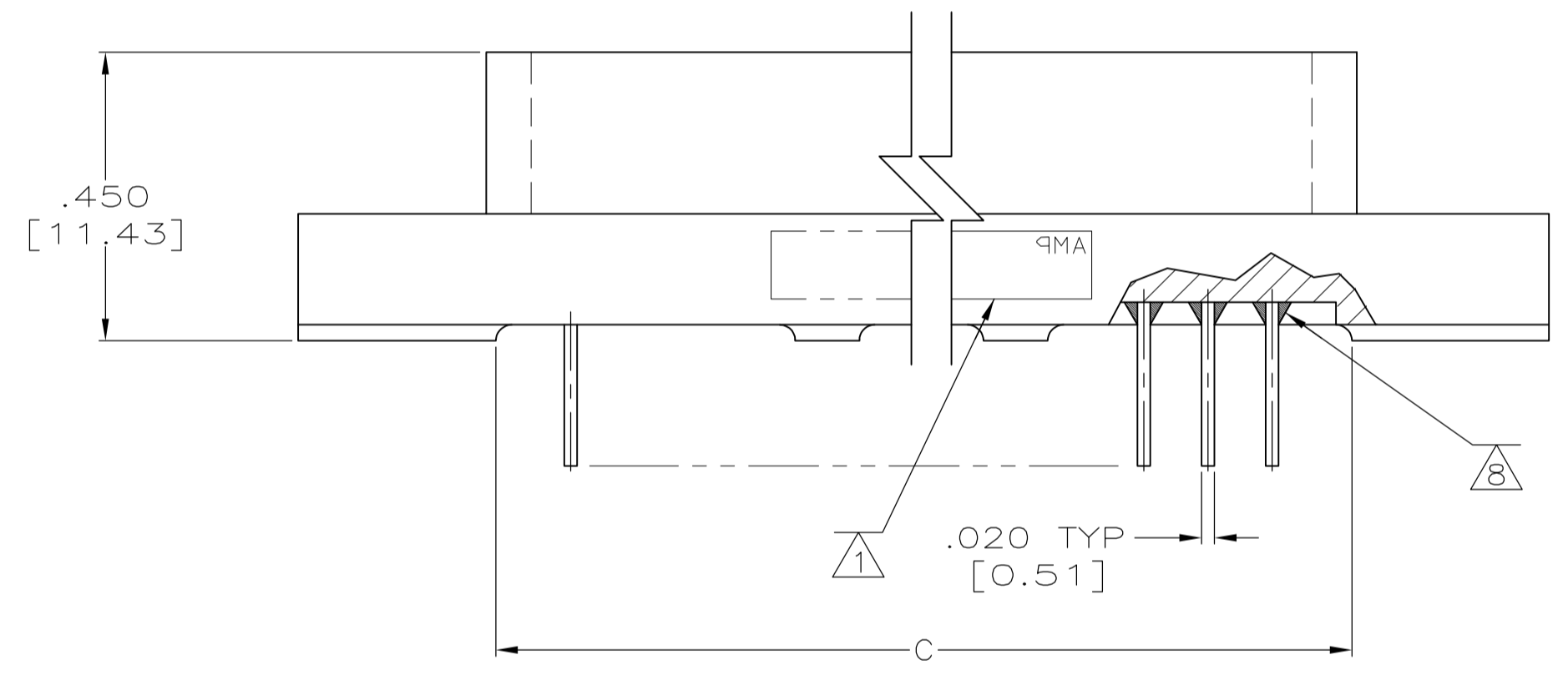
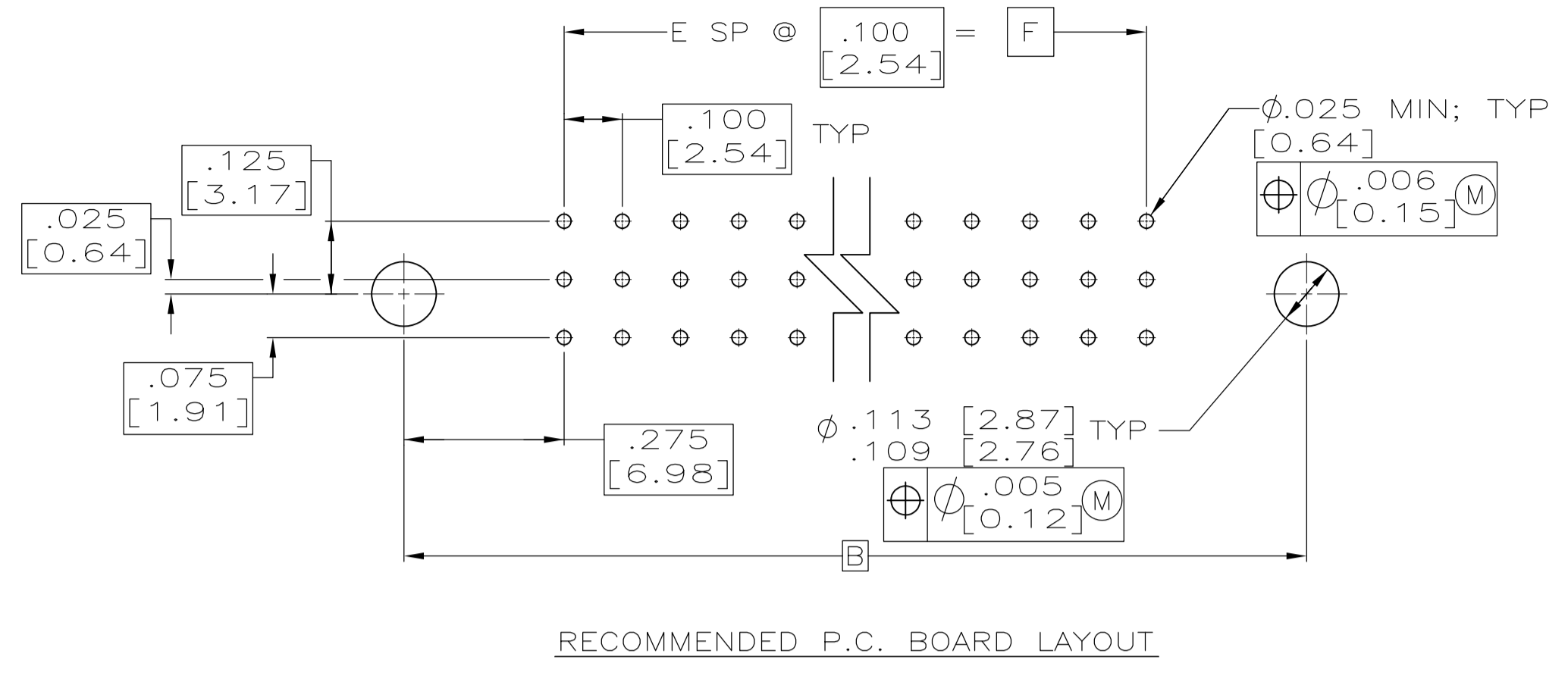
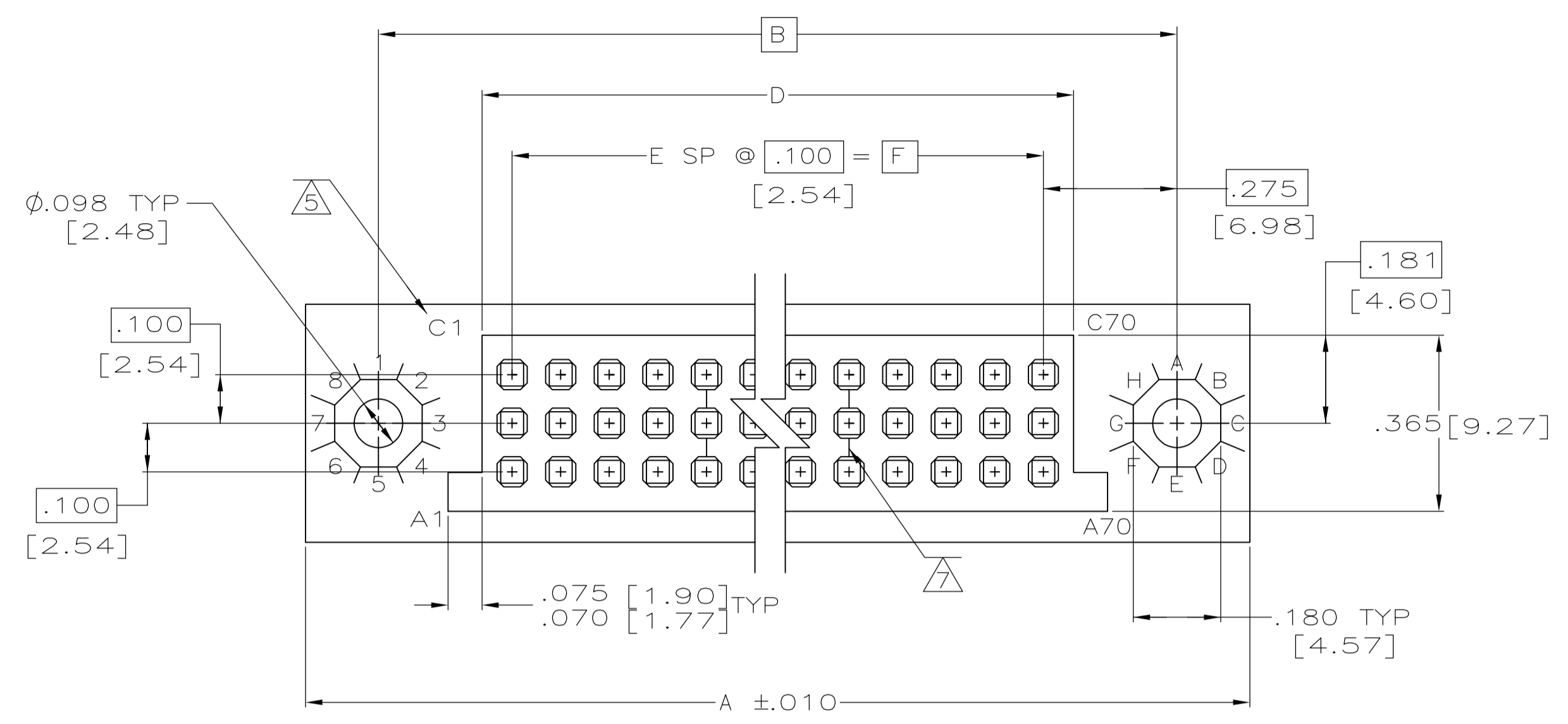
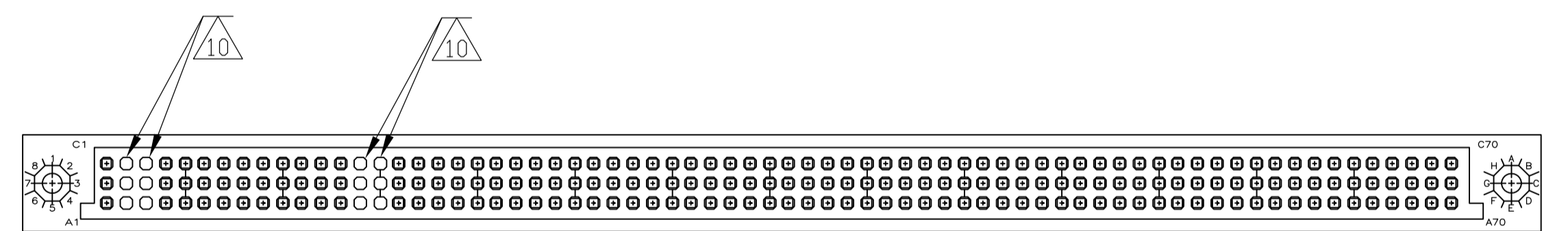

1996169-2

- 1 CUSTOMER CAGE CODE AND PART NO.(SEE TABLE), 00779, DATE CODE, TE PART NO. AND AMP MARKED ON OPPOSITE SIDE.
- 2 HOUSING MAT'L: POLYPHENYLENE SULFIDE, GST-40F PER MIL-M-24519. COLOR: BROWN.
- 3 CONTACT MAT'L: BERYLLIUM COPPER PER ASTM B194 OR COPPER-NICKEL-SILICON PER UNS-C70260.
- 4 CONTACT FINISH: .000050" [0.00127] GOLD IN CONTACT AREA, .000100" [0.0025] TIN-LEAD ON SOLDER TAILS OVER .000030 [0.00076] NICKEL ON ENTIRE CONTACT.
- 5 LETTERS INDICATING OUTSIDE ROWS AND NUMBERS INDICATING END CAVITIES MARKED ON THIS SURFACE.
- 6 MEETS ALL REQUIREMENTS OF MIL-C-55302.
- 7 LINES INDICATING EVERY FIVE CAVITIES MARKED ON MATING FACE EXCEPT END CAVITIES STARTING AT POSN. #1.
- 8 EPOXY SEALANT ADDED TO PREVENT WICKING OF FLUX OR CONFORMAL COATING INTO THE CONTACT ENGAGEMENT AREA.
- 9 CONTACT REMOVED FROM POSITION A2, B2 & C2 FOR 1996169-1 ONLY. EMPTY CAVITIES ARE SEALED WITH EPOXY.
- 10 CONTACT REMOVED FROM POSITION A2, B2, C2, A3, B3, C3, A14, B14, C14, A15, B15 & C15 FOR 1996169-2 ONLY. EMPTY CAVITIES ARE SEALED WITH EPOXY.

REMARKS	CUSTOMER P/N	F	E	D	C	B	A	POSN	PART NO
10	04804-4A48273H04	6.900 [175.26]	69	7.024 [178.41]	7.125 [180.97]	7.450 [189.23]	7.750 [196.85]	198	1996169-2
9	04804-4A48273H03	6.900 [175.26]	69	7.024 [178.41]	7.125 [180.97]	7.450 [189.23]	7.750 [196.85]	207	1996169-1

THIS DRAWING IS A CONTROLLED DOCUMENT.

DIMENSIONS: INCHES [mm]	TOLERANCES UNLESS OTHERWISE SPECIFIED:	DMN: C.C.THOMAS 2-6-08	APVD: J.WEAVER 2-6-08	NAME: J.WEAVER	PRODUCT SPEC: --	APPLICATION SPEC: --	SIZE: A1	SCALE: 4:1	SHEET: 1 OF 1	REV: E
0 PLC ± -	1 PLC ± -	2 PLC ± -	3 PLC ± .005 [0.13]	4 PLC ± -	ANGLES ± -	FINISH: --	WEIGHT: --	CUSTOMER DRAWING	SCALE: 4:1	SHEET: 1 OF 1

Tyco Electronics Corporation  
 Harrisburg, PA 17105-3608

BOX RECEPTACLE ASS'Y, .100 C/L, 3-ROW, SEALED, .010 X .020 SOLDER TAIL, .025 OFFSET, SELECT LOAD

00779 1996169