

THE INFORMATION CONTAINED HEREIN IS CONSIDERED "PROPRIETARY" TO BEL FUSE INC. AND SHALL NOT BE COPIED, REPRODUCED OR DISCLOSED WITHOUT THE WRITTEN APPROVAL OF BEL FUSE INC.

RoHS



**ELECTRICAL CHARACTERISTICS @ 25°C**

**URNS RATIO**

TX	1CT : 1
RX	1CT : 1
QCL @ 100kHz/100mVRMS	350µH MIN.
8mA DC BIAS	
INS. LOSS	
1MHZ TO 100MHZ	-1.0 dB MAX
RET. LOSS (MIN)	
1MHZ-30MHZ	-18 dB
30MHZ-60MHZ	-18+20LOG(F/30MHZ) dB
60MHZ-80MHZ	-12 dB
CROSS TALK (TX - RX)	
500kHz - 100 MHz	-35 dB MIN
CM TO CM REJ	
100kHz - 100 MHz	-30 dB MIN
CM TO DM REJ	
100kHz - 100 MHz	-40 dB MIN

HIPOT (Isolation Voltage): 1500 Vrms  
 100% OF PRODUCTION TESTED TO COMPLY WITH IEEE 802.3 ISOLATION REQUIREMENTS.

LED 1			
VF (FORWARD VOLTAGE)	IF=20mA	YELLOW	2.1V TYP.
λD (DOMINANT WAVELENGTH)	IF=20mA	YELLOW	590nm TYP.
LED 2			
VF (FORWARD VOLTAGE)	IF=20mA	ORANGE	2.0V TYP.
		GREEN	2.2V TYP.
λD (DOMINANT WAVELENGTH)	IF=20mA	ORANGE	605nm TYP.
		GREEN	570nm TYP.

OPERATING TEMPERATURE: 0°C TO 70°C.

LED1 POLARITY			LED2 POLARITY		
PIN 7	PIN 8	COLOR	PIN 9	PIN 10	COLOR
-	+	YELLOW	+	-	ORANGE
/	/	/	-	+	GREEN

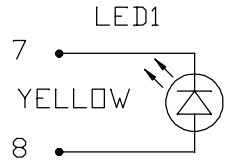

**SCHEMATIC**

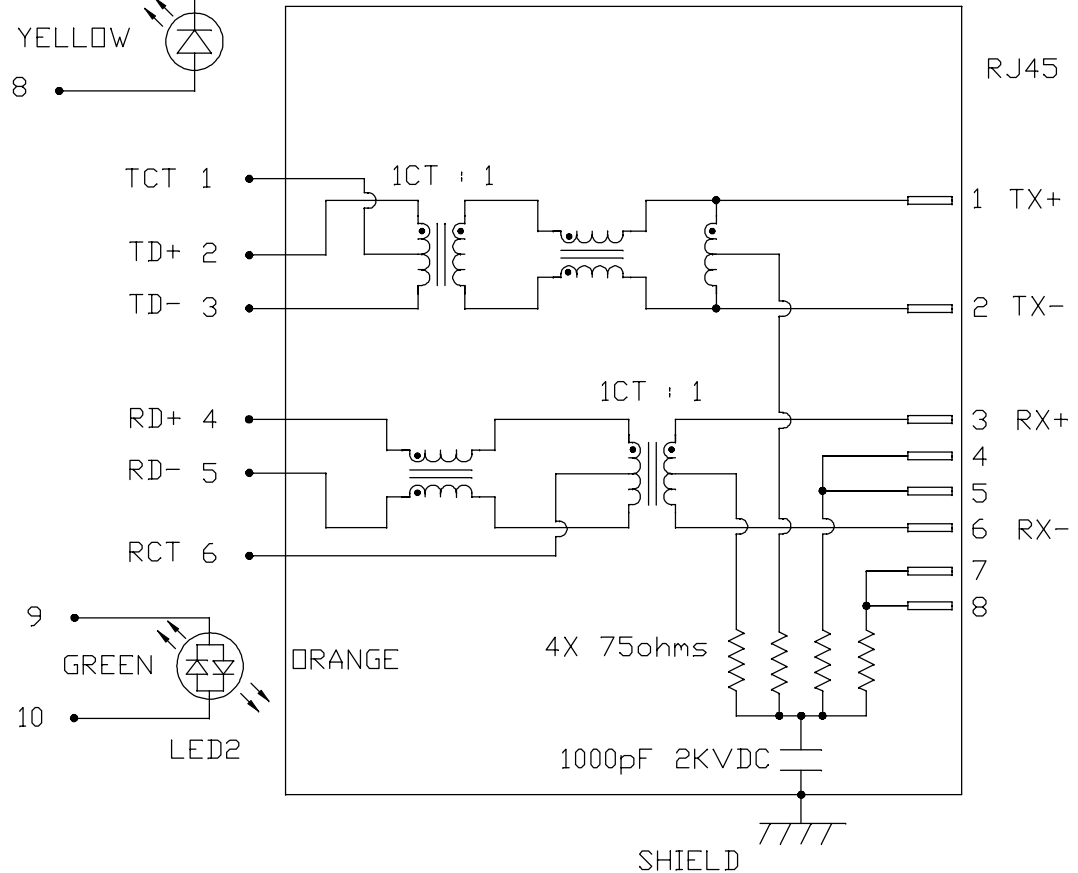

ORIGINATED BY CHOW WANGCHUNG DATE 2018-12-17
DRAWN BY XIE YIMING DATE 2018-12-17

TITLE  MagJack® (CM Termination) 08B0-1X1T-03-F
---

PART NO. / DRAWING NO. 08B01X1T03-F
FILE NAME 08B01X1T03-F_D.DWG

STANDARD DIM. TOL. IN INCH	[ ] METRIC DIM. AS REF.
.X	UNIT : INCH [mm]
.XX	SCALE : N/A
.XXX	SIZE : A4

REV. : D	PAGE : 2
----------	----------



THE INFORMATION CONTAINED HEREIN IS CONSIDERED 'PROPRIETARY' TO BEL FUSE INC. AND SHALL NOT BE COPIED, REPRODUCED OR DISCLOSED WITHOUT THE WRITTEN APPROVAL OF BEL FUSE INC.

MECHANICAL SPECIFICATION

RoHS

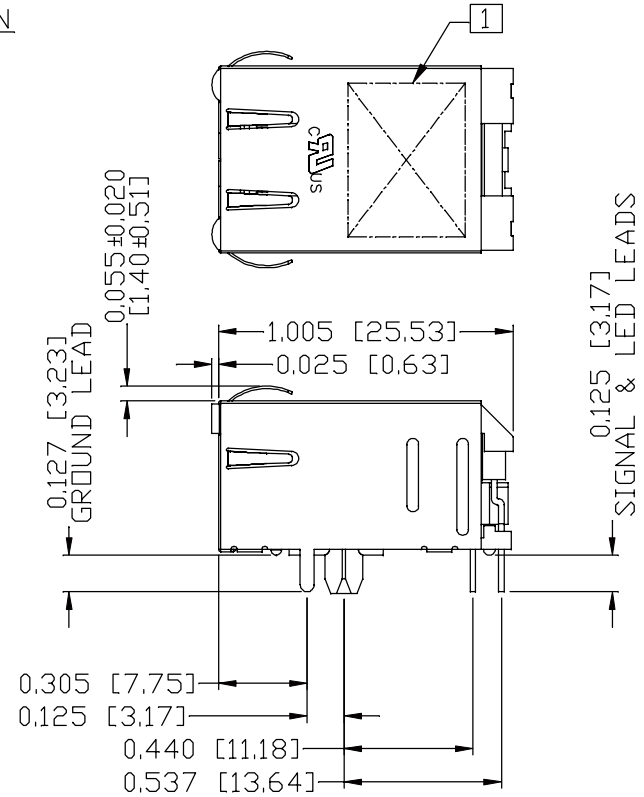
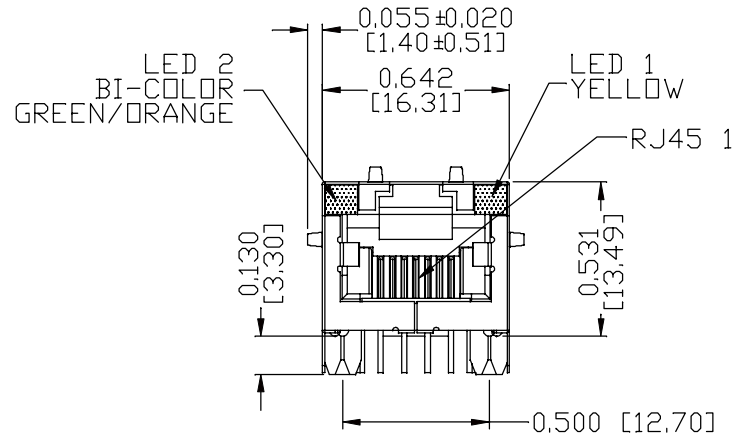

NOTES:

- PLASTIC HOUSING: THERMOPLASTIC PBT, BLACK  
FLAMMABILITY RATING UL 94V-0
- CONTACTS PLATING: 15 MICRO-INCH HARD GOLD PLATING OR EQUIVALENT.
- PINS: TIN-COATED COPPER WIRE, DIA 0.018 INCH.  
100 MICRO-INCH MIN MATTE TIN.  
PINS ARE SOLDER DIPPED.
- METAL SHIELD: PRE-PLATED NICKEL ON COPPER ALLOY.  
(ALL GROUND LEADS ARE SOLDER DIPPED)

1. MARK PART WITH MFG LOGO, MFG NAME, PART NUMBER AND DATE CODE.

- 2. THE PRODUCT IS RoHS COMPLIANT.
- 3. JACK CAVITY CONFORMS TO FCC RULES AND REGULATIONS, PART 68 SUBPART F.
- 4. THE AXIAL RETENTION FORCE OF RJ PORT IS 10 LBS MINIMUM.
- 5. THE PART IS RECOMMENDED FOR WAVE SOLDERING. THE SUGGESTED PEAK WAVE SOLDERING CONDITION IS 260°C MAX AND 10 SECONDS MAX.

UL RECOGNIZED - FILE #E196366 AND E169987.

REV. : D      PAGE : 3

ORIGINATED BY  
LI QUANKUN  
DATE 2018-12-17  
DRAWN BY  
LV YONGDONG  
DATE 2018-12-17

TITLE  
MagJack®  
(CM Termination)  
08B0-1X1T-03-F

PART NO. / DRAWING NO.  
08B01X1T03-F  
FILE NAME  
08B01X1T03-F\_D.DWG

STANDARD DIM. TOL. IN INCH	[ ] METRIC DIM. AS REF.
.X	UNIT : INCH [mm]
.XX	SCALE : N/A
.XXX	SIZE : A4



THE INFORMATION CONTAINED HEREIN IS CONSIDERED "PROPRIETARY" TO BEL FUSE INC. AND SHALL NOT BE COPIED, REPRODUCED OR DISCLOSED WITHOUT THE WRITTEN APPROVAL OF BEL FUSE INC.

RoHS



RECOMMENDED PCB FOOTPRINT  
COMPONENT SIDE VIEW

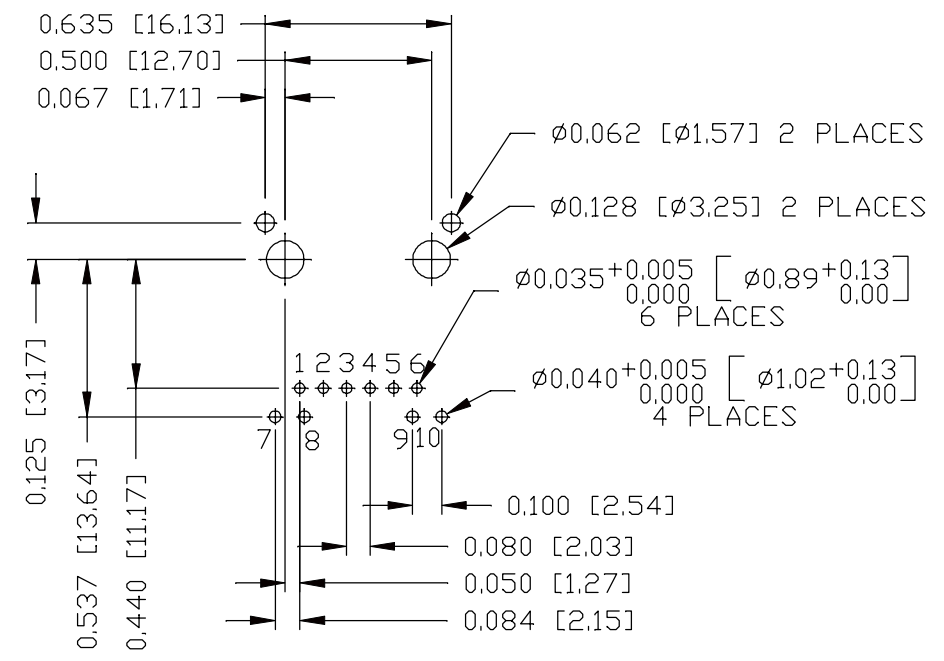
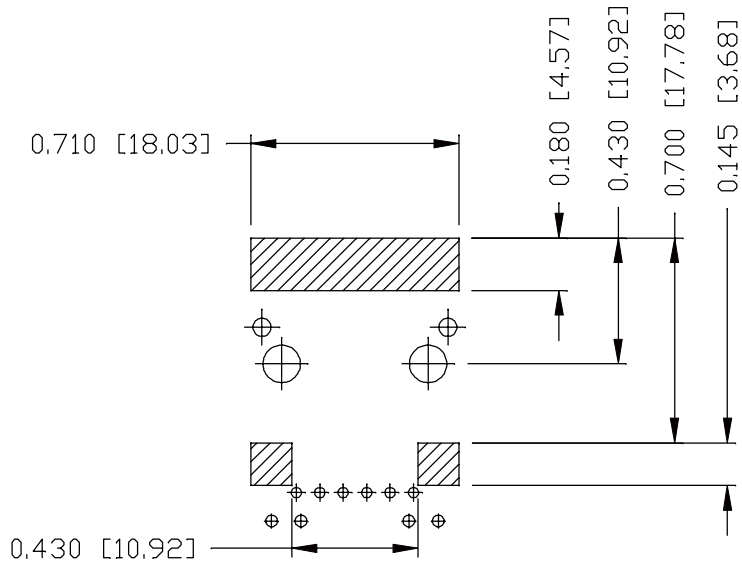

NOTES:

THE SHADED AREA ON THE CUSTOMER BOARD ARE RECOMMENDED TO BE CLEAR OFF ANY VIA HOLE OR COMPONENT PAD.

REV. : D PAGE : 4

ORIGINATED BY  
LI QUANKUN  
DATE 2018-12-17  
DRAWN BY  
LV YONGDONG  
DATE 2018-12-17

TITLE  
MagJack®  
(CM Termination)  
08B0-1X1T-03-F

PART NO. / DRAWING NO.  
08B01X1T03-F  
FILE NAME  
08B01X1T03-F\_D.DWG

STANDARD DIM. TOL. IN INCH	[ ] METRIC DIM. AS REF.
.X	UNIT : INCH [mm]
.XX	SCALE : N/A
.XXX ±0.004	SIZE : A4



THE INFORMATION CONTAINED HEREIN IS CONSIDERED "PROPRIETARY" TO BEL FUSE INC. AND SHALL NOT BE COPIED, REPRODUCED OR DISCLOSED WITHOUT THE WRITTEN APPROVAL OF BEL FUSE INC.



SUGGESTED PANEL OPENING

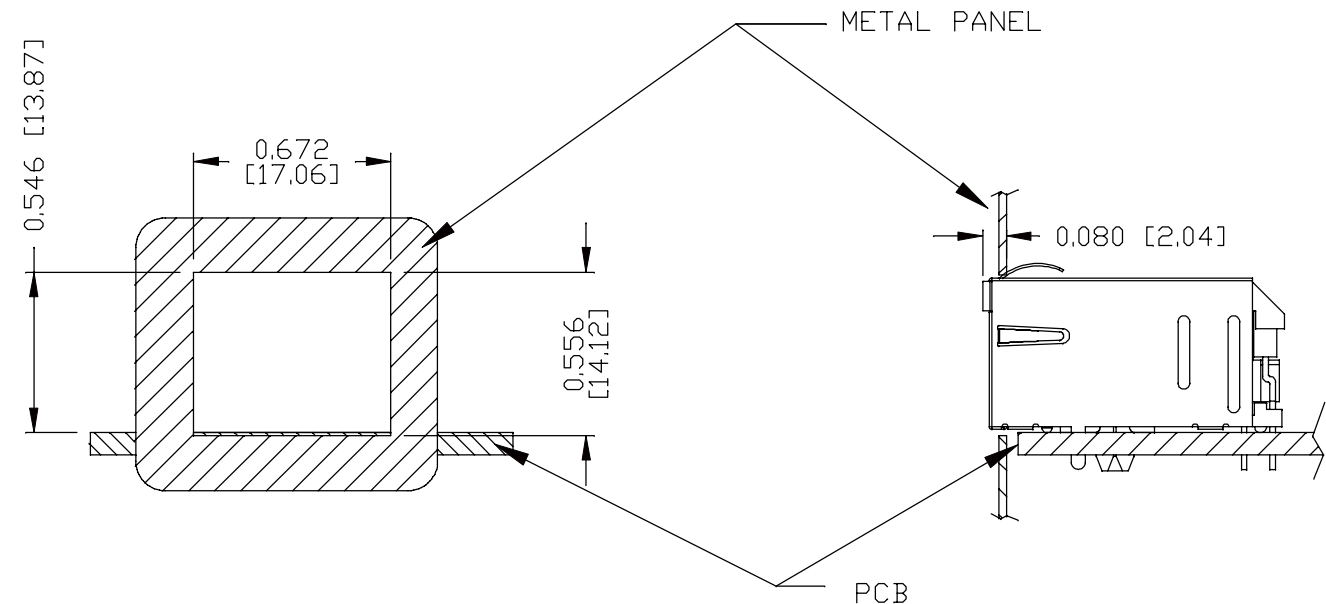

NOTE:

THE DISTANCE OF PANEL INSIDE SURFACE RELATIVE TO FRONT SURFACE OF PART IS ONLY A SUGGESTION. IN CASE THIS DISTANCE IS DIFFERENT, THE REQUIRED PANEL OPENING DIMENSIONS CHANGE ACCORDINGLY.

PACKING INFORMATION

PACKING TRAY : 0200-9999-D4(TOP)  
0200-9999-D5(BOTTOM)

PACKING QUANTITY : 60 PCS FINISHED GOODS PER TRAY  
11 TRAYS (660 PCS FINISHED GOODS) PER CARTON BOX

NOTE : CARDBOARDS ARE PLACED BETWEEN LAYERS OF PACKING TRAY INSIDE CARTON BOX  
(INCLUDE THE UPPERMOST AND LOWERMOST TRAY)

REV. : D	PAGE : 5
----------	----------

ORIGINATED BY LI QUANKUN DATE 2018-12-17 DRAWN BY LV YONGDONG DATE 2018-12-17	TITLE  MagJack® (CM Termination) 08B0-1X1T-03-F	PART NO. / DRAWING NO. 08B01X1T03-F	STANDARD DIM. TOL. IN INCH .X	[ ] METRIC DIM. AS REF.
		FILE NAME 08B01X1T03-F_D.DWG	UNIT : INCH [mm] SCALE : N/A	SIZE : A4
		±0.005		

