

PowerFilm[®]

MADE IN THE USA

SOLAR

AEM-PF-EVK Solar Development Kit with e-peas PMIC (DEV-EPEAS)

System Overview

The AEM-PF-EVK Solar Development Kit with e-peas PMIC (DEV-EPEAS) makes integrating solar into electronics simple. It includes an e-peas high-performance energy harvesting PMIC with integrated power management designed and optimized for PowerFilm's thin-film indoor and outdoor solar panels. Use Indoor Light series panels for indoor applications and use Classic Application panels for outdoor environments.

The AEM-PF-EVK efficiently extracts energy from the solar modules, which can be stored in a rechargeable element while also providing two independent regulated voltages to power IoT devices. The integrated power management supports multiple storage element charge configurations, including, Li-Po, Li-ion, LiFePO4, Solid State, and Single/Double cell supercapacitors. Configurations are easily selected by moving pin jumpers to desired positions.

See Quick Start Guide for details on configuring storage element type and other board options.

Kit Contents

- AEM-PF-EVK Dev Kit PCBA
- (2) MPT2.4-21 Classic Application Solar Panel with 6" leads
- (2) LL200-2.4-37 Indoor Solar Panel with 6" leads
- 60mAh rechargeable Li-Polymer battery
- Instructions and product documentation

Use Cases - Power Source For

- BLE Beacons and Tags
- E-Paper Displays
- Telematics
- Smart Locks
- Thermostats
- Smart Windows and Shades
- Wireless Sensors
- Wearables
- Field and Herd Monitoring
- Other Low Power Electronics

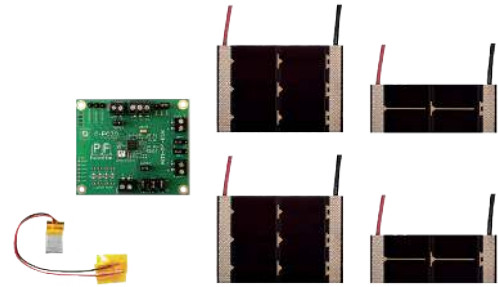

Solar panel leads cropped for photo

Panel Specifications

Indoor Series	Classic Application
LL200-2.4-37	MPT2.4-21
1000 lux:	100% Sun
• 0.449mW	• 34mW
• 0.214mA	• 14.2mA
• 2.1V	• 2.4V
200 lux:	25% Sun
• 0.068mW	• 7.7mW
• 0.043mA	• 3.2mA
• 1.6V	• 2.4V

System Diagram

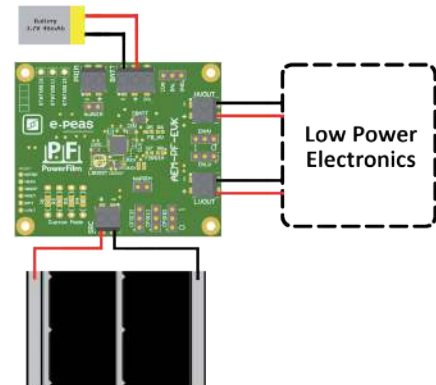

PowerFilm[®]

MADE IN THE USA

SOLAR

Features

Energy Harvester and Power Management

- Cold start at $3\mu\text{W}$ 380mV
- Global quiescent current of 400nA
- MPPT ratio configured to 70%
- Storage element voltage protection
- Primary battery with minimum voltage protection
- Two LDO power output rails with enable pins
- Dual cell supercapacitor balancing circuit
- Internal boost converter (up to 95%): 50mV to 5V

Connectors

- Screw connector for PowerFilm PV cell
- Screw connector for storage element
- Multiple PCB footprints for supercapacitors
- Screw connector for primary battery
- Screw connector for HVOUT LDO output (80mA)
- Screw connector for LVOU LDO output (20mA)

Configuration

- CFG selection jumpers for storage element type
- Resistors footprints for custom mode
- Jumpers for output enable/disable
- Jumpers for primary battery option
- Jumper for supercapacitor cell balancing circuit enable

Size

- 58 mm x 49 mm
- 4 x M 2.5 Mounting holes

Board Layout

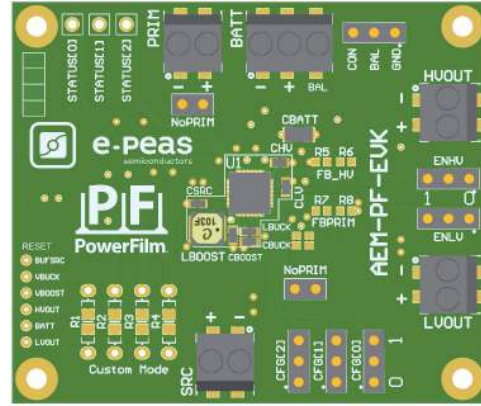

IV Curves

Indoor Series

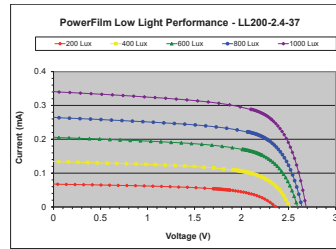

Classic Application

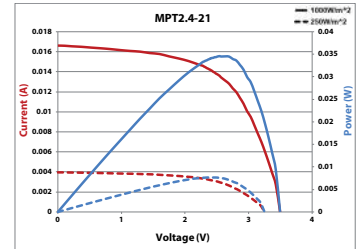

Notes

Harvesting indoor light with the paired LL200-2.4-37 panel provides approximately $80\mu\text{W}$ in a low light luminosity (200 lux). After eight hours of exposure, the AEM10941 harvester will collect about 1.8 J of energy. Harvesting outdoor light with the paired MPT2.4-21 panel provides approximately 6.8mW under indirect or ambient sunlight (25% of direct sunlight). After eight hours of exposure, the AEM10941 harvester will collect about 156 J of energy.

