



KA78XXE/KA78XXAE 3-Terminal 1A Positive Voltage Regulator

Features

- Output Current up to 1A
- Output Voltages of 5, 6, 8, 9, 10, 12, 15, 18, 24V
- Thermal Overload Protection
- Short Circuit Protection
- Output Transistor Safe Operating Area Protection

Description

The KA78XXE/KA78XXAE series of three-terminal positive regulator are available in the TO-220/D-PAK package and with several fixed output voltages, making them useful in a wide range of applications. Each type employs internal current limiting, thermal shut down and safe operating area protection, making it essentially indestructible. If adequate heat sinking is provided, they can deliver over 1A output current. Although designed primarily as fixed voltage regulators, these devices can be used with external components to obtain adjustable voltages and currents.

Ordering Information

Part Number	Output Voltage Tolerance	Package	Operating Temperature		
KA7805E / KA7806E	±4%	TO-220	0 to +125°C		
KA7808E / KA7809E					
KA7810E					
KA7812E / KA7815E					
KA7818E / KA7824E					
KA7805AE / KA7806AE	±2%			D-PAK	0 to +125°C
KA7808AE / KA7809AE					
KA7810AE					
KA7812AE/KA7815AE					
KA7818AE/KA7824AE					
KA7805ER / KA7806ER	±4%	D-PAK	0 to +125°C		
KA7808ER / KA7809ER					
KA7812ER					

Block Diagram

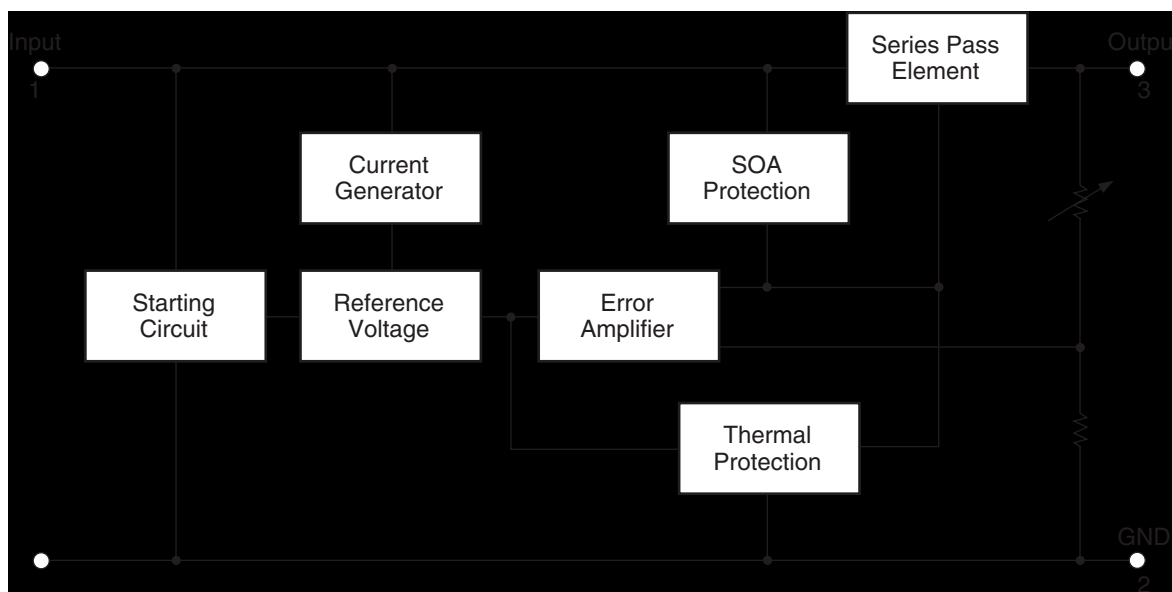

Figure 1.

Pin Assignment

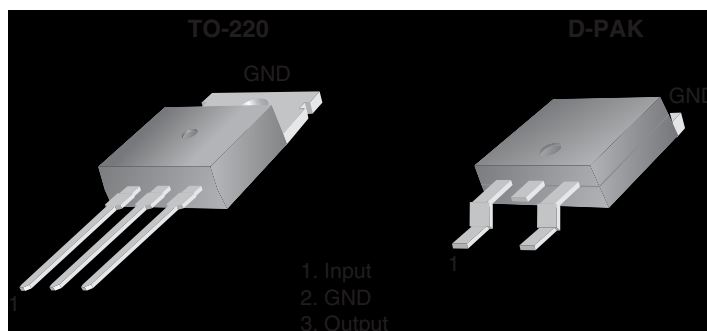

Figure 2.

Absolute Maximum Ratings

Symbol	Parameter		Value	Unit
V_I	Input Voltage	$V_O = 5V \text{ to } 18V$	35	V
		$V_O = 24V$	40	
$R_{\theta JC}$	Thermal Resistance Junction-Cases (TO-220)		5	$^{\circ}C/W$
$R_{\theta JA}$	Thermal Resistance Junction-Air (TO-220)		65	$^{\circ}C/W$
T_{OPR}	Operating Temperature Range (KA78XXE/AE/ER)		0 to +125	$^{\circ}C$
T_{STG}	Storage Temperature Range		-65 to +150	$^{\circ}C$

Electrical Characteristics (KA7805E/KA7805ER)Refer to test circuit, $0^{\circ}\text{C} < T_J < 125^{\circ}\text{C}$, $I_O = 500\text{mA}$, $V_I = 10\text{V}$, $C_I = 0.33\mu\text{F}$, $C_O = 0.1\mu\text{F}$, unless otherwise specified.

Symbol	Parameter	Conditions	KA7805E/ER			Unit	
			Min.	Typ.	Max.		
V_O	Output Voltage	$T_J = +25^{\circ}\text{C}$	4.8	5.0	5.2	V	
		$5.0\text{mA} \leq I_O \leq 1.0\text{A}$, $P_O \leq 15\text{W}$ $V_I = 7\text{V to } 20\text{V}$	4.75	5.0	5.25		
Regline	Line Regulation ⁽¹⁾	$T_J = +25^{\circ}\text{C}$	$V_O = 7\text{V to } 25\text{V}$	–	4.0	100	mV
			$V_I = 8\text{V to } 12\text{V}$	–	1.6	50	
Regload	Load Regulation ⁽¹⁾	$T_J = +25^{\circ}\text{C}$	$I_O = 5.0\text{mA to } 1.5\text{A}$	–	9	100	mV
			$I_O = 250\text{mA to } 750\text{mA}$	–	4	50	
I_Q	Quiescent Current	$T_J = +25^{\circ}\text{C}$	–	5.0	8.0	mA	
ΔI_Q	Quiescent Current Change	$I_O = 5\text{mA to } 1.0\text{A}$	–	0.03	0.5	mA	
		$V_I = 7\text{V to } 25\text{V}$	–	0.3	1.3		
$\Delta V_O/\Delta T$	Output Voltage Drift ⁽²⁾	$I_O = 5\text{mA}$	–	-0.8	–	mV/ $^{\circ}\text{C}$	
V_N	Output Noise Voltage	$f = 10\text{Hz to } 100\text{kHz}$, $T_A = +25^{\circ}\text{C}$	–	42	–	$\mu\text{V}/V_O$	
RR	Ripple Rejection ⁽²⁾	$f = 120\text{Hz}$, $V_O = 8\text{V to } 18\text{V}$	62	73	–	dB	
V_{Drop}	Dropout Voltage	$I_O = 1\text{A}$, $T_J = +25^{\circ}\text{C}$	–	2	–	V	
r_O	Output Resistance ⁽²⁾	$f = 1\text{kHz}$	–	15	–	m Ω	
I_{SC}	Short Circuit Current	$V_I = 35\text{V}$, $T_A = +25^{\circ}\text{C}$	–	230	–	mA	
I_{PK}	Peak Current ⁽²⁾	$T_J = +25^{\circ}\text{C}$	–	2.2	–	A	

Notes:

1. Load and line regulation are specified at constant junction temperature. Changes in V_O due to heating effects must be taken into account separately. Pulse testing with low duty is used.
2. These parameters, although guaranteed, are not 100% tested in production.

Electrical Characteristics (KA7806E/KA7806ER) (Continued)Refer to test circuit, $0^{\circ}\text{C} < T_J < 125^{\circ}\text{C}$, $I_O = 500\text{mA}$, $V_I = 11\text{V}$, $C_I = 0.33\mu\text{F}$, $C_O = 0.1\mu\text{F}$, unless otherwise specified.

Symbol	Parameter	Conditions	KA7806E/ER			Unit	
			Min.	Typ.	Max.		
V_O	Output Voltage	$T_J = +25^{\circ}\text{C}$	5.75	6.0	6.25	V	
		$5.0\text{mA} \leq I_O \leq 1.0\text{A}$, $P_O \leq 15\text{W}$ $V_I = 8.0\text{V to } 21\text{V}$	5.7	6.0	6.3		
Regline	Line Regulation ⁽³⁾	$T_J = +25^{\circ}\text{C}$	$V_I = 8\text{V to } 25\text{V}$	–	5	120	mV
			$V_I = 9\text{V to } 13\text{V}$	–	1.5	60	
Regload	Load Regulation ⁽³⁾	$T_J = +25^{\circ}\text{C}$	$I_O = 5\text{mA to } 1.5\text{A}$	–	9	120	mV
			$I_O = 250\text{mA to } 750\text{mA}$	–	3	60	
I_Q	Quiescent Current	$T_J = +25^{\circ}\text{C}$	–	5.0	8.0	mA	
ΔI_Q	Quiescent Current Change	$I_O = 5\text{mA to } 1\text{A}$	–	–	0.5	mA	
		$V_I = 8\text{V to } 25\text{V}$	–	–	1.3		
$\Delta V_O/\Delta T$	Output Voltage Drift ⁽⁴⁾	$I_O = 5\text{mA}$	–	-0.8	–	mV/ $^{\circ}\text{C}$	
V_N	Output Noise Voltage	$f = 10\text{Hz to } 100\text{kHz}$, $T_A = +25^{\circ}\text{C}$	–	45	–	$\mu\text{V}/V_O$	
RR	Ripple Rejection ⁽⁴⁾	$f = 120\text{Hz}$ $V_I = 9\text{V to } 19\text{V}$	59	75	–	dB	
V_{Drop}	Dropout Voltage	$I_O = 1\text{A}$, $T_J = +25^{\circ}\text{C}$	–	2	–	V	
r_O	Output Resistance ⁽⁴⁾	$f = 1\text{kHz}$	–	19	–	m Ω	
I_{SC}	Short Circuit Current	$V_I = 35\text{V}$, $T_A = +25^{\circ}\text{C}$	–	250	–	mA	
I_{PK}	Peak Current ⁽⁴⁾	$T_J = +25^{\circ}\text{C}$	–	2.2	–	A	

Notes:

- Load and line regulation are specified at constant junction temperature. Changes in V_O due to heating effects must be taken into account separately. Pulse testing with low duty is used.
- These parameters, although guaranteed, are not 100% tested in production.

Electrical Characteristics (KA7808E/KA7808ER) (Continued)Refer to test circuit, $0^{\circ}\text{C} < T_J < 125^{\circ}\text{C}$, $I_O = 500\text{mA}$, $V_I = 14\text{V}$, $C_I = 0.33\mu\text{F}$, $C_O = 0.1\mu\text{F}$, unless otherwise specified.

Symbol	Parameter	Conditions	KA7808E/ER			Unit	
			Min.	Typ.	Max.		
V_O	Output Voltage	$T_J = +25^{\circ}\text{C}$	7.7	8.0	8.3	V	
		$5.0\text{mA} \leq I_O \leq 1.0\text{A}$, $P_O \leq 15\text{W}$ $V_I = 10.5\text{V to } 23\text{V}$	7.6	8.0	8.4		
Regline	Line Regulation ⁽⁵⁾	$T_J = +25^{\circ}\text{C}$	$V_I = 10.5\text{V to } 25\text{V}$	–	5.0	160	mV
			$V_I = 11.5\text{V to } 17\text{V}$	–	2.0	80	
Regload	Load Regulation ⁽⁵⁾	$T_J = +25^{\circ}\text{C}$	$I_O = 5.0\text{mA to } 1.5\text{A}$	–	10	160	mV
			$I_O = 250\text{mA to } 750\text{mA}$	–	5.0	80	
I_Q	Quiescent Current	$T_J = +25^{\circ}\text{C}$	–	5.0	8.0	mA	
ΔI_Q	Quiescent Current Change	$I_O = 5\text{mA to } 1.0\text{A}$	–	0.05	0.5	mA	
		$V_I = 10.5\text{V to } 25\text{V}$	–	0.5	1.0		
$\Delta V_O/\Delta T$	Output Voltage Drift ⁽⁶⁾	$I_O = 5\text{mA}$	–	-0.8	–	mV/ $^{\circ}\text{C}$	
V_N	Output Noise Voltage	$f = 10\text{Hz to } 100\text{kHz}$, $T_A = +25^{\circ}\text{C}$	–	52	–	$\mu\text{V}/V_O$	
RR	Ripple Rejection ⁽⁶⁾	$f = 120\text{Hz}$, $V_I = 11.5\text{V to } 21.5\text{V}$	56	73	–	dB	
V_{Drop}	Dropout Voltage	$I_O = 1\text{A}$, $T_J = +25^{\circ}\text{C}$	–	2	–	V	
r_O	Output Resistance ⁽⁶⁾	$f = 1\text{kHz}$	–	17	–	m Ω	
I_{SC}	Short Circuit Current	$V_I = 35\text{V}$, $T_A = +25^{\circ}\text{C}$	–	230	–	mA	
I_{PK}	Peak Current ⁽⁶⁾	$T_J = +25^{\circ}\text{C}$	–	2.2	–	A	

Notes:

- Load and line regulation are specified at constant junction temperature. Changes in V_O due to heating effects must be taken into account separately. Pulse testing with low duty is used.
- These parameters, although guaranteed, are not 100% tested in production.

Electrical Characteristics (KA7809E/KA7809ER) (Continued)Refer to test circuit, $0^{\circ}\text{C} < T_J < 125^{\circ}\text{C}$, $I_O = 500\text{mA}$, $V_I = 15\text{V}$, $C_I = 0.33\mu\text{F}$, $C_O = 0.1\mu\text{F}$, unless otherwise specified.

Symbol	Parameter	Conditions	KA7809E/ER			Unit	
			Min.	Typ.	Max.		
V_O	Output Voltage	$T_J = +25^{\circ}\text{C}$	8.65	9	9.35	V	
		$5.0\text{mA} \leq I_O \leq 1.0\text{A}$, $P_O \leq 15\text{W}$ $V_I = 11.5\text{V to } 24\text{V}$	8.6	9	9.4		
Regline	Line Regulation ⁽⁷⁾	$T_J = +25^{\circ}\text{C}$	$V_I = 11.5\text{V to } 25\text{V}$	–	6	180	mV
			$V_I = 12\text{V to } 17\text{V}$	–	2	90	
Regload	Load Regulation ⁽⁷⁾	$T_J = +25^{\circ}\text{C}$	$I_O = 5\text{mA to } 1.5\text{A}$	–	12	180	mV
			$I_O = 250\text{mA to } 750\text{mA}$	–	4	90	
I_Q	Quiescent Current	$T_J = +25^{\circ}\text{C}$	–	5.0	8.0	mA	
ΔI_Q	Quiescent Current Change	$I_O = 5\text{mA to } 1.0\text{A}$	–	–	0.5	mA	
		$V_I = 11.5\text{V to } 26\text{V}$	–	–	1.3		
$\Delta V_O/\Delta T$	Output Voltage Drift ⁽⁸⁾	$I_O = 5\text{mA}$	–	-1	–	mV/ $^{\circ}\text{C}$	
V_N	Output Noise Voltage	$f = 10\text{Hz to } 100\text{kHz}$, $T_A = +25^{\circ}\text{C}$	–	58	–	$\mu\text{V}/V_O$	
RR	Ripple Rejection ⁽⁸⁾	$f = 120\text{Hz}$ $V_I = 13\text{V to } 23\text{V}$	56	71	–	dB	
V_{Drop}	Dropout Voltage	$I_O = 1\text{A}$, $T_J = +25^{\circ}\text{C}$	–	2	–	V	
r_O	Output Resistance ⁽⁸⁾	$f = 1\text{kHz}$	–	17	–	m Ω	
I_{SC}	Short Circuit Current	$V_I = 35\text{V}$, $T_A = +25^{\circ}\text{C}$	–	250	–	mA	
I_{PK}	Peak Current ⁽⁸⁾	$T_J = +25^{\circ}\text{C}$	–	2.2	–	A	

Notes:

7. Load and line regulation are specified at constant junction temperature. Changes in V_O due to heating effects must be taken into account separately. Pulse testing with low duty is used.
8. These parameters, although guaranteed, are not 100% tested in production.

Electrical Characteristics (KA7810E) (Continued)Refer to test circuit, $0^{\circ}\text{C} < T_J < 125^{\circ}\text{C}$, $I_O = 500\text{mA}$, $V_I = 16\text{V}$, $C_I = 0.33\mu\text{F}$, $C_O = 0.1\mu\text{F}$, unless otherwise specified.

Symbol	Parameter	Conditions	KA7810E			Unit	
			Min.	Typ.	Max.		
V_O	Output Voltage	$T_J = +25^{\circ}\text{C}$	9.6	10.0	10.4	V	
		$5\text{mA} \leq I_O \leq 1\text{A}$, $P_O \leq 15\text{W}$ $V_I = 12.5\text{V to } 25\text{V}$	9.5	10.0	10.5		
Regline	Line Regulation ⁽⁹⁾	$T_J = +25^{\circ}\text{C}$	$V_I = 12.5\text{V to } 25\text{V}$	–	10.0	200	mV
			$V_I = 13\text{V to } 25\text{V}$	–	3.0	100	
Regload	Load Regulation ⁽⁹⁾	$T_J = +25^{\circ}\text{C}$	$I_O = 5\text{mA to } 1.5\text{A}$	–	12.0	200	mV
			$I_O = 250\text{mA to } 750\text{mA}$	–	4.0	400	
I_Q	Quiescent Current	$T_J = +25^{\circ}\text{C}$	–	5.1	8.0	mA	
ΔI_Q	Quiescent Current Change	$I_O = 5\text{mA to } 1\text{A}$	–	–	0.5	mA	
		$V_I = 12.5\text{V to } 29\text{V}$	–	–	1.0		
$\Delta V_O/\Delta T$	Output Voltage Drift ⁽¹⁰⁾	$I_O = 5\text{mA}$	–	-1.0	–	mV/ $^{\circ}\text{C}$	
V_N	Output Noise Voltage	$f = 10\text{Hz to } 100\text{kHz}$, $T_A = +25^{\circ}\text{C}$	–	58.0	–	$\mu\text{V}/V_O$	
RR	Ripple Rejection ⁽¹⁰⁾	$f = 120\text{Hz}$ $V_O = 13\text{V to } 23\text{V}$	56.0	71.0	–	dB	
V_{Drop}	Dropout Voltage	$I_O = 1\text{A}$, $T_J = +25^{\circ}\text{C}$	–	2.0	–	V	
r_O	Output Resistance ⁽¹⁰⁾	$f = 1\text{kHz}$	–	17.0	–	m Ω	
I_{SC}	Short Circuit Current	$V_I = 35\text{V}$, $T_A = +25^{\circ}\text{C}$	–	250	–	mA	
I_{PK}	Peak Current ⁽¹⁰⁾	$T_J = +25^{\circ}\text{C}$	–	2.2	–	A	

Notes:

9. Load and line regulation are specified at constant junction temperature. Changes in V_O due to heating effects must be taken into account separately. Pulse testing with low duty is used.
10. These parameters, although guaranteed, are not 100% tested in production.

Electrical Characteristics (KA7812E/KA7812ER) (Continued)Refer to test circuit, $0^{\circ}\text{C} < T_J < 125^{\circ}\text{C}$, $I_O = 500\text{mA}$, $V_I = 19\text{V}$, $C_I = 0.33\mu\text{F}$, $C_O = 0.1\mu\text{F}$, unless otherwise specified.

Symbol	Parameter	Conditions	KA7812E/ER			Unit	
			Min.	Typ.	Max.		
V_O	Output Voltage	$T_J = +25^{\circ}\text{C}$	11.5	12	12.5	V	
		$5.0\text{mA} \leq I_O \leq 1.0\text{A}$, $P_O \leq 15\text{W}$ $V_I = 14.5\text{V to } 27\text{V}$	11.4	12	12.6		
Regline	Line Regulation ⁽¹¹⁾	$T_J = +25^{\circ}\text{C}$	$V_I = 14.5\text{V to } 30\text{V}$	–	10	240	mV
			$V_I = 16\text{V to } 22\text{V}$	–	3.0	120	
Regload	Load Regulation ⁽¹¹⁾	$T_J = +25^{\circ}\text{C}$	$I_O = 5\text{mA to } 1.5\text{A}$	–	11	240	mV
			$I_O = 250\text{mA to } 750\text{mA}$	–	5.0	120	
I_Q	Quiescent Current	$T_J = +25^{\circ}\text{C}$	–	5.1	8.0	mA	
ΔI_Q	Quiescent Current Change	$I_O = 5\text{mA to } 1.0\text{A}$	–	0.1	0.5	mA	
		$V_I = 14.5\text{V to } 30\text{V}$	–	0.5	1.0		
$\Delta V_O/\Delta T$	Output Voltage Drift ⁽¹²⁾	$I_O = 5\text{mA}$	–	-1	–	mV/ $^{\circ}\text{C}$	
V_N	Output Noise Voltage	$f = 10\text{Hz to } 100\text{kHz}$, $T_A = +25^{\circ}\text{C}$	–	76	–	$\mu\text{V}/V_O$	
RR	Ripple Rejection ⁽¹²⁾	$f = 120\text{Hz}$ $V_I = 15\text{V to } 25\text{V}$	55	71	–	dB	
V_{Drop}	Dropout Voltage	$I_O = 1\text{A}$, $T_J = +25^{\circ}\text{C}$	–	2	–	V	
r_O	Output Resistance ⁽¹²⁾	$f = 1\text{kHz}$	–	18	–	m Ω	
I_{SC}	Short Circuit Current	$V_I = 35\text{V}$, $T_A = +25^{\circ}\text{C}$	–	230	–	mA	
I_{PK}	Peak Current ⁽¹²⁾	$T_J = +25^{\circ}\text{C}$	–	2.2	–	A	

Notes:

11. Load and line regulation are specified at constant junction temperature. Changes in V_O due to heating effects must be taken into account separately. Pulse testing with low duty is used.
12. These parameters, although guaranteed, are not 100% tested in production.

Electrical Characteristics (KA7815E) (Continued)Refer to test circuit, $0^{\circ}\text{C} < T_J < 125^{\circ}\text{C}$, $I_O = 500\text{mA}$, $V_I = 23\text{V}$, $C_I = 0.33\mu\text{F}$, $C_O = 0.1\mu\text{F}$, unless otherwise specified.

Symbol	Parameter	Conditions	KA7815E			Unit	
			Min.	Typ.	Max.		
V_O	Output Voltage	$T_J = +25^{\circ}\text{C}$	14.4	15	15.6	V	
		$5.0\text{mA} \leq I_O \leq 1.0\text{A}$, $P_O \leq 15\text{W}$ $V_I = 17.5\text{V to } 30\text{V}$	14.25	15	15.75		
Regline	Line Regulation ⁽¹³⁾	$T_J = +25^{\circ}\text{C}$	$V_I = 17.5\text{V to } 30\text{V}$	–	11	300	mV
			$V_I = 20\text{V to } 26\text{V}$	–	3	150	
Regload	Load Regulation ⁽¹³⁾	$T_J = +25^{\circ}\text{C}$	$I_O = 5\text{mA to } 1.5\text{A}$	–	12	300	mV
			$I_O = 250\text{mA to } 750\text{mA}$	–	4	150	
I_Q	Quiescent Current	$T_J = +25^{\circ}\text{C}$	–	5.2	8.0	mA	
ΔI_Q	Quiescent Current Change	$I_O = 5\text{mA to } 1.0\text{A}$	–	–	0.5	mA	
		$V_I = 17.5\text{V to } 30\text{V}$	–	–	1.0		
$\Delta V_O/\Delta T$	Output Voltage Drift ⁽¹⁴⁾	$I_O = 5\text{mA}$	–	-1	–	mV/ $^{\circ}\text{C}$	
V_N	Output Noise Voltage	$f = 10\text{Hz to } 100\text{kHz}$, $T_A = +25^{\circ}\text{C}$	–	90	–	$\mu\text{V}/V_O$	
RR	Ripple Rejection ⁽¹⁴⁾	$f = 120\text{Hz}$ $V_I = 18.5\text{V to } 28.5\text{V}$	54	70	–	dB	
V_{Drop}	Dropout Voltage	$I_O = 1\text{A}$, $T_J = +25^{\circ}\text{C}$	–	2	–	V	
r_O	Output Resistance ⁽¹⁴⁾	$f = 1\text{kHz}$	–	19	–	m Ω	
I_{SC}	Short Circuit Current	$V_I = 35\text{V}$, $T_A = +25^{\circ}\text{C}$	–	250	–	mA	
I_{PK}	Peak Current ⁽¹⁴⁾	$T_J = +25^{\circ}\text{C}$	–	2.2	–	A	

Notes:

13. Load and line regulation are specified at constant junction temperature. Changes in V_O due to heating effects must be taken into account separately. Pulse testing with low duty is used.
14. These parameters, although guaranteed, are not 100% tested in production.

Electrical Characteristics (KA7818E) (Continued)Refer to test circuit, $0^{\circ}\text{C} < T_J < 125^{\circ}\text{C}$, $I_O = 500\text{mA}$, $V_I = 27\text{V}$, $C_I = 0.33\mu\text{F}$, $C_O = 0.1\mu\text{F}$, unless otherwise specified.

Symbol	Parameter	Conditions	KA7818E			Unit	
			Min.	Typ.	Max.		
V_O	Output Voltage	$T_J = +25^{\circ}\text{C}$	17.3	18	18.7	V	
		$5.0\text{mA} \leq I_O \leq 1.0\text{A}$, $P_O \leq 15\text{W}$ $V_I = 21\text{V to } 33\text{V}$	17.1	18	18.9		
Regline	Line Regulation ⁽¹⁵⁾	$T_J = +25^{\circ}\text{C}$	$V_I = 21\text{V to } 33\text{V}$	–	15	360	mV
			$V_I = 24\text{V to } 30\text{V}$	–	5	180	
Regload	Load Regulation ⁽¹⁵⁾	$T_J = +25^{\circ}\text{C}$	$I_O = 5\text{mA to } 1.5\text{A}$	–	15	360	mV
			$I_O = 250\text{mA to } 750\text{mA}$	–	5.0	180	
I_Q	Quiescent Current	$T_J = +25^{\circ}\text{C}$	–	5.2	8.0	mA	
ΔI_Q	Quiescent Current Change	$I_O = 5\text{mA to } 1.0\text{A}$	–	–	0.5	mA	
		$V_I = 21\text{V to } 33\text{V}$	–	–	1		
$\Delta V_O/\Delta T$	Output Voltage Drift ⁽¹⁶⁾	$I_O = 5\text{mA}$	–	-1	–	mV/ $^{\circ}\text{C}$	
V_N	Output Noise Voltage	$f = 10\text{Hz to } 100\text{kHz}$, $T_A = +25^{\circ}\text{C}$	–	110	–	$\mu\text{V}/V_O$	
RR	Ripple Rejection ⁽¹⁶⁾	$f = 120\text{Hz}$ $V_I = 22\text{V to } 32\text{V}$	53	69	–	dB	
V_{Drop}	Dropout Voltage	$I_O = 1\text{A}$, $T_J = +25^{\circ}\text{C}$	–	2	–	V	
r_O	Output Resistance ⁽¹⁶⁾	$f = 1\text{kHz}$	–	22	–	m Ω	
I_{SC}	Short Circuit Current	$V_I = 35\text{V}$, $T_A = +25^{\circ}\text{C}$	–	250	–	mA	
I_{PK}	Peak Current ⁽¹⁶⁾	$T_J = +25^{\circ}\text{C}$	–	2.2	–	A	

Notes:

15. Load and line regulation are specified at constant junction temperature. Changes in V_O due to heating effects must be taken into account separately. Pulse testing with low duty is used.

16. These parameters, although guaranteed, are not 100% tested in production.

Electrical Characteristics (KA7824E) (Continued)Refer to test circuit, $0^{\circ}\text{C} < T_J < 125^{\circ}\text{C}$, $I_O = 500\text{mA}$, $V_I = 33\text{V}$, $C_I = 0.33\mu\text{F}$, $C_O = 0.1\mu\text{F}$, unless otherwise specified.

Symbol	Parameter	Conditions	KA7824E			Unit	
			Min.	Typ.	Max.		
V_O	Output Voltage	$T_J = +25^{\circ}\text{C}$	23	24	25	V	
		$5.0\text{mA} \leq I_O \leq 1.0\text{A}$, $P_O \leq 15\text{W}$ $V_I = 27\text{V to } 38\text{V}$	22.8	24	25.25		
Regline	Line Regulation ⁽¹⁷⁾	$T_J = +25^{\circ}\text{C}$	$V_I = 27\text{V to } 38\text{V}$	–	17	480	mV
			$V_I = 30\text{V to } 36\text{V}$	–	6	240	
Regload	Load Regulation ⁽¹⁷⁾	$T_J = +25^{\circ}\text{C}$	$I_O = 5\text{mA to } 1.5\text{A}$	–	15	480	mV
			$I_O = 250\text{mA to } 750\text{mA}$	–	5.0	240	
I_Q	Quiescent Current	$T_J = +25^{\circ}\text{C}$	–	5.2	8.0	mA	
ΔI_Q	Quiescent Current Change	$I_O = 5\text{mA to } 1.0\text{A}$	–	0.1	0.5	mA	
		$V_I = 27\text{V to } 38\text{V}$	–	0.5	1		
$\Delta V_O/\Delta T$	Output Voltage Drift ⁽¹⁸⁾	$I_O = 5\text{mA}$	–	-1.5	–	mV/ $^{\circ}\text{C}$	
V_N	Output Noise Voltage	$f = 10\text{Hz to } 100\text{kHz}$, $T_A = +25^{\circ}\text{C}$	–	60	–	$\mu\text{V}/V_O$	
RR	Ripple Rejection ⁽¹⁸⁾	$f = 120\text{Hz}$ $V_I = 28\text{V to } 38\text{V}$	50	67	–	dB	
V_{Drop}	Dropout Voltage	$I_O = 1\text{A}$, $T_J = +25^{\circ}\text{C}$	–	2	–	V	
r_O	Output Resistance ⁽¹⁸⁾	$f = 1\text{kHz}$	–	28	–	m Ω	
I_{SC}	Short Circuit Current	$V_I = 35\text{V}$, $T_A = +25^{\circ}\text{C}$	–	230	–	mA	
I_{PK}	Peak Current ⁽¹⁸⁾	$T_J = +25^{\circ}\text{C}$	–	2.2	–	A	

Notes:

17. Load and line regulation are specified at constant junction temperature. Changes in V_O due to heating effects must be taken into account separately. Pulse testing with low duty is used.
18. These parameters, although guaranteed, are not 100% tested in production.

Electrical Characteristics (KA7805AE) (Continued)Refer to the test circuits. $0^{\circ}\text{C} < T_J < +125^{\circ}\text{C}$, $I_O = 1\text{A}$, $V_I = 10\text{V}$, $C_I = 0.33\mu\text{F}$, $C_O = 0.1\mu\text{F}$, unless otherwise specified.

Symbol	Parameter	Conditions	KA7805AE			Unit
			Min.	Typ.	Max.	
V_O	Output Voltage	$T_J = +25^{\circ}\text{C}$	4.9	5	5.1	V
		$I_O = 5\text{mA to } 1\text{A}$, $P_O \leq 15\text{W}$ $V_I = 7.5\text{V to } 20\text{V}$	4.8	5	5.2	
Regline	Line Regulation ⁽¹⁹⁾	$V_I = 7.5\text{V to } 25\text{V}$ $I_O = 500\text{mA}$	–	5	50	mV
		$V_I = 8\text{V to } 12\text{V}$	–	3	50	
		$T_J = +25^{\circ}\text{C}$ $V_I = 7.3\text{V to } 20\text{V}$	–	5	50	
		$V_I = 8\text{V to } 12\text{V}$	–	1.5	25	
Regload	Load Regulation ⁽¹⁹⁾	$T_J = +25^{\circ}\text{C}$ $I_O = 5\text{mA to } 1.5\text{A}$	–	9	100	mV
		$I_O = 5\text{mA to } 1\text{A}$	–	9	100	
		$I_O = 250\text{mA to } 750\text{mA}$	–	4	50	
I_Q	Quiescent Current	$T_J = +25^{\circ}\text{C}$	–	5.0	6.0	mA
ΔI_Q	Quiescent Current Change	$I_O = 5\text{mA to } 1\text{A}$	–	–	0.5	mA
		$V_I = 8\text{V to } 25\text{V}$, $I_O = 500\text{mA}$	–	–	0.8	
		$V_I = 7.5\text{V to } 20\text{V}$, $T_J = +25^{\circ}\text{C}$	–	–	0.8	
$\Delta V/\Delta T$	Output Voltage Drift ⁽²⁰⁾	$I_O = 5\text{mA}$	–	-0.8	–	mV/ $^{\circ}\text{C}$
V_N	Output Noise Voltage	$f = 10\text{Hz to } 100\text{kHz}$ $T_A = +25^{\circ}\text{C}$	–	10	–	$\mu\text{V}/V_O$
RR	Ripple Rejection ⁽²⁰⁾	$f = 120\text{Hz}$, $I_O = 500\text{mA}$ $V_I = 8\text{V to } 18\text{V}$	–	68	–	dB
V_{Drop}	Dropout Voltage	$I_O = 1\text{A}$, $T_J = +25^{\circ}\text{C}$	–	2	–	V
r_O	Output Resistance ⁽²⁰⁾	$f = 1\text{kHz}$	–	17	–	m Ω
I_{SC}	Short Circuit Current	$V_I = 35\text{V}$, $T_A = +25^{\circ}\text{C}$	–	250	–	mA
I_{PK}	Peak Current ⁽²⁰⁾	$T_J = +25^{\circ}\text{C}$	–	2.2	–	A

Notes:

19. Load and line regulation are specified at constant junction temperature. Change in V_O due to heating effects must be taken into account separately. Pulse testing with low duty is used.

20. These parameters, although guaranteed, are not 100% tested in production.

Electrical Characteristics (KA7806AE) (Continued)Refer to the test circuits. $0^{\circ}\text{C} < T_J < +125^{\circ}\text{C}$, $I_O = 1\text{A}$, $V_I = 11\text{V}$, $C_I = 0.33\mu\text{F}$, $C_O = 0.1\mu\text{F}$, unless otherwise specified.

Symbol	Parameter	Conditions	KA7806AE			Unit	
			Min.	Typ.	Max.		
V_O	Output Voltage	$T_J = +25^{\circ}\text{C}$	5.58	6	6.12	V	
		$I_O = 5\text{mA to } 1\text{A}$, $P_O \leq 15\text{W}$ $V_I = 8.6\text{V to } 21\text{V}$	5.76	6	6.24		
Regline	Line Regulation ⁽²¹⁾	$V_I = 8.6\text{V to } 25\text{V}$, $I_O = 500\text{mA}$	–	5	60	mV	
		$V_I = 9\text{V to } 13\text{V}$	–	3	60		
		$T_J = +25^{\circ}\text{C}$	$V_I = 8.3\text{V to } 21\text{V}$	–	5		60
			$V_I = 9\text{V to } 13\text{V}$	–	1.5		30
Regload	Load Regulation ⁽²¹⁾	$T_J = +25^{\circ}\text{C}$, $I_O = 5\text{mA to } 1.5\text{A}$	–	9	100	mV	
		$I_O = 5\text{mA to } 1\text{A}$	–	9	100		
		$I_O = 250\text{mA to } 750\text{mA}$	–	5.0	50		
I_Q	Quiescent Current	$T_J = +25^{\circ}\text{C}$	–	4.3	6.0	mA	
ΔI_Q	Quiescent Current Change	$I_O = 5\text{mA to } 1\text{A}$	–	–	0.5	mA	
		$V_I = 9\text{V to } 25\text{V}$, $I_O = 500\text{mA}$	–	–	0.8		
		$V_I = 8.5\text{V to } 21\text{V}$, $T_J = +25^{\circ}\text{C}$	–	–	0.8		
$\Delta V/\Delta T$	Output Voltage Drift ⁽²²⁾	$I_O = 5\text{mA}$	–	-0.8	–	mV/ $^{\circ}\text{C}$	
V_N	Output Noise Voltage	$f = 10\text{Hz to } 100\text{kHz}$, $T_A = +25^{\circ}\text{C}$	–	10	–	$\mu\text{V}/V_O$	
RR	Ripple Rejection ⁽²²⁾	$f = 120\text{Hz}$, $I_O = 500\text{mA}$ $V_I = 9\text{V to } 19\text{V}$	–	65	–	dB	
V_{Drop}	Dropout Voltage	$I_O = 1\text{A}$, $T_J = +25^{\circ}\text{C}$	–	2	–	V	
r_O	Output Resistance ⁽²²⁾	$f = 1\text{kHz}$	–	17	–	m Ω	
I_{SC}	Short Circuit Current	$V_I = 35\text{V}$, $T_A = +25^{\circ}\text{C}$	–	250	–	mA	
I_{PK}	Peak Current ⁽²²⁾	$T_J = +25^{\circ}\text{C}$	–	2.2	–	A	

Notes:

21. Load and line regulation are specified at constant junction temperature. Change in V_O due to heating effects must be taken into account separately. Pulse testing with low duty is used.
22. These parameters, although guaranteed, are not 100% tested in production.

Electrical Characteristics (KA7808AE) (Continued)Refer to the test circuits. $0^{\circ}\text{C} < T_J < +125^{\circ}\text{C}$, $I_O = 1\text{A}$, $V_I = 14\text{V}$, $C_I = 0.33\mu\text{F}$, $C_O = 0.1\mu\text{F}$, unless otherwise specified.

Symbol	Parameter	Conditions	KA7808AE			Unit	
			Min.	Typ.	Max.		
V_O	Output Voltage	$T_J = +25^{\circ}\text{C}$	7.84	8	8.16	V	
		$I_O = 5\text{mA to } 1\text{A}$, $P_O \leq 15\text{W}$ $V_I = 10.6\text{V to } 23\text{V}$	7.7	8	8.3		
Regline	Line Regulation ⁽²³⁾	$V_I = 10.6\text{V to } 25\text{V}$, $I_O = 500\text{mA}$	–	6	80	mV	
		$V_I = 11\text{V to } 17\text{V}$	–	3	80		
		$T_J = +25^{\circ}\text{C}$	$V_I = 10.4\text{V to } 23\text{V}$	–	6		80
			$V_I = 11\text{V to } 17\text{V}$	–	2		40
Regload	Load Regulation ⁽²³⁾	$T_J = +25^{\circ}\text{C}$, $I_O = 5\text{mA to } 1.5\text{A}$	–	12	100	mV	
		$I_O = 5\text{mA to } 1\text{A}$	–	12	100		
		$I_O = 250\text{mA to } 750\text{mA}$	–	5	50		
I_Q	Quiescent Current	$T_J = +25^{\circ}\text{C}$	–	5.0	6.0	mA	
ΔI_Q	Quiescent Current Change	$I_O = 5\text{mA to } 1\text{A}$	–	–	0.5	mA	
		$V_I = 11\text{V to } 25\text{V}$, $I_O = 500\text{mA}$	–	–	0.8		
		$V_I = 10.6\text{V to } 23\text{V}$, $T_J = +25^{\circ}\text{C}$	–	–	0.8		
$\Delta V/\Delta T$	Output Voltage Drift ⁽²⁴⁾	$I_O = 5\text{mA}$	–	-0.8	–	mV/ $^{\circ}\text{C}$	
V_N	Output Noise Voltage	$f = 10\text{Hz to } 100\text{kHz}$, $T_A = +25^{\circ}\text{C}$	–	10	–	$\mu\text{V}/V_O$	
RR	Ripple Rejection ⁽²⁴⁾	$f = 120\text{Hz}$, $I_O = 500\text{mA}$ $V_I = 11.5\text{V to } 21.5\text{V}$	–	62	–	dB	
V_{Drop}	Dropout Voltage	$I_O = 1\text{A}$, $T_J = +25^{\circ}\text{C}$	–	2	–	V	
r_O	Output Resistance ⁽²⁴⁾	$f = 1\text{kHz}$	–	18	–	m Ω	
I_{SC}	Short Circuit Current	$V_I = 35\text{V}$, $T_A = +25^{\circ}\text{C}$	–	250	–	mA	
I_{PK}	Peak Current ⁽²⁴⁾	$T_J = +25^{\circ}\text{C}$	–	2.2	–	A	

Notes:

23. Load and line regulation are specified at constant junction temperature. Change in V_O due to heating effects must be taken into account separately. Pulse testing with low duty is used.
24. These parameters, although guaranteed, are not 100% tested in production.

Electrical Characteristics (KA7809AE) (Continued)Refer to the test circuits. $0^{\circ}\text{C} < T_J < +125^{\circ}\text{C}$, $I_O = 1\text{A}$, $V_I = 15\text{V}$, $C_I = 0.33\mu\text{F}$, $C_O = 0.1\mu\text{F}$, unless otherwise specified.

Symbol	Parameter	Conditions	KA7809AE			Unit	
			Min.	Typ.	Max.		
V_O	Output Voltage	$T_J = +25^{\circ}\text{C}$	8.82	9.0	9.18	V	
		$I_O = 5\text{mA to } 1\text{A}$, $P_O \leq 15\text{W}$ $V_I = 11.2\text{V to } 24\text{V}$	8.65	9.0	9.35		
Regline	Line Regulation ⁽²⁵⁾	$V_I = 11.7\text{V to } 25\text{V}$, $I_O = 500\text{mA}$	–	6	90	mV	
		$V_I = 12.5\text{V to } 19\text{V}$	–	4	45		
		$T_J = +25^{\circ}\text{C}$	$V_I = 11.5\text{V to } 24\text{V}$	–	6		90
		$V_I = 12.5\text{V to } 19\text{V}$	–	2	45		
Regload	Load Regulation ⁽²⁵⁾	$T_J = +25^{\circ}\text{C}$, $I_O = 5\text{mA to } 1.0\text{A}$	–	12	100	mV	
		$I_O = 5\text{mA to } 1.0\text{A}$	–	12	100		
		$I_O = 250\text{mA to } 750\text{mA}$	–	5	50		
I_Q	Quiescent Current	$T_J = +25^{\circ}\text{C}$	–	5.0	6.0	mA	
ΔI_Q	Quiescent Current Change	$V_I = 11.7\text{V to } 25\text{V}$, $T_J = +25^{\circ}\text{C}$	–	–	0.8	mA	
		$V_I = 12\text{V to } 25\text{V}$, $I_O = 500\text{mA}$	–	–	0.8		
		$I_O = 5\text{mA to } 1.0\text{A}$	–	–	0.5		
$\Delta V/\Delta T$	Output Voltage Drift ⁽²⁶⁾	$I_O = 5\text{mA}$	–	-1.0	–	mV/ $^{\circ}\text{C}$	
V_N	Output Noise Voltage	$f = 10\text{Hz to } 100\text{kHz}$, $T_A = +25^{\circ}\text{C}$	–	10	–	$\mu\text{V}/V_O$	
RR	Ripple Rejection ⁽²⁶⁾	$f = 120\text{Hz}$, $I_O = 500\text{mA}$ $V_I = 12\text{V to } 22\text{V}$	–	62	–	dB	
V_{Drop}	Dropout Voltage	$I_O = 1\text{A}$, $T_J = +25^{\circ}\text{C}$	–	2.0	–	V	
r_O	Output Resistance ⁽²⁶⁾	$f = 1\text{kHz}$	–	17	–	m Ω	
I_{SC}	Short Circuit Current	$V_I = 35\text{V}$, $T_A = +25^{\circ}\text{C}$	–	250	–	mA	
I_{PK}	Peak Current ⁽²⁶⁾	$T_J = +25^{\circ}\text{C}$	–	2.2	–	A	

Notes:

25. Load and line regulation are specified at constant junction temperature. Change in V_O due to heating effects must be taken into account separately. Pulse testing with low duty is used.
26. These parameters, although guaranteed, are not 100% tested in production.

Electrical Characteristics (KA7810AE) (Continued)Refer to the test circuits. $0^{\circ}\text{C} < T_J < +125^{\circ}\text{C}$, $I_O = 1\text{A}$, $V_I = 16\text{V}$, $C_I = 0.33\mu\text{F}$, $C_O = 0.1\mu\text{F}$, unless otherwise specified.

Symbol	Parameter	Conditions	KA7810AE			Unit	
			Min.	Typ.	Max.		
V_O	Output Voltage	$T_J = +25^{\circ}\text{C}$	9.8	10.0	10.2	V	
		$I_O = 5\text{mA to } 1\text{A}$, $P_O \leq 15\text{W}$ $V_I = 12.8\text{V to } 25\text{V}$	9.6	10.0	10.4		
Regline	Line Regulation ⁽²⁷⁾	$V_I = 12.8\text{V to } 26\text{V}$, $I_O = 500\text{mA}$	–	8.0	100	mV	
		$V_I = 13\text{V to } 20\text{V}$	–	4.0	50.0		
		$T_J = +25^{\circ}\text{C}$	$V_I = 12.5\text{V to } 25\text{V}$ $V_I = 13\text{V to } 20\text{V}$	–	8.0		100
		–		3.0	50.0		
Regload	Load Regulation ⁽²⁷⁾	$T_J = +25^{\circ}\text{C}$, $I_O = 5\text{mA to } 1.5\text{A}$	–	12.0	100	mV	
		$I_O = 5\text{mA to } 1\text{mA}$	–	12.0	100		
		$I_O = 250\text{mA to } 750\text{mA}$	–	5.0	50.0		
I_Q	Quiescent Current	$T_J = +25^{\circ}\text{C}$	–	5.0	6.0	mA	
ΔI_Q	Quiescent Current Change	$I_O = 5\text{mA to } 1\text{A}$	–	–	0.5	mA	
		$V_I = 12.8\text{V to } 25\text{V}$, $I_O = 500\text{mA}$	–	–	0.8		
		$V_I = 13\text{V to } 26\text{V}$, $T_J = +25^{\circ}\text{C}$	–	–	0.5		
$\Delta V_O/\Delta T$	Output Voltage Drift ⁽²⁸⁾	$I_O = 5\text{mA}$	–	-1.0	–	mV/ $^{\circ}\text{C}$	
V_N	Output Noise Voltage	$f = 10\text{Hz to } 100\text{kHz}$, $T_A = +25^{\circ}\text{C}$	–	10.0	–	$\mu\text{V}/V_O$	
RR	Ripple Rejection ⁽²⁸⁾	$f = 120\text{Hz}$, $I_O = 500\text{mA}$ $V_I = 14\text{V to } 24\text{V}$	–	62.0	–	dB	
V_{Drop}	Dropout Voltage	$I_O = 1\text{A}$, $T_J = +25^{\circ}\text{C}$	–	2.0	–	V	
r_O	Output Resistance ⁽²⁸⁾	$f = 1\text{kHz}$	–	17.0	–	m Ω	
I_{SC}	Short Circuit Current	$V_I = 35\text{V}$, $T_A = +25^{\circ}\text{C}$	–	250	–	mA	
I_{PK}	Peak Current ⁽²⁸⁾	$T_J = +25^{\circ}\text{C}$	–	2.2	–	A	

Notes:

27. Load and line regulation are specified at constant junction temperature. Change in V_O due to heating effects must be taken into account separately. Pulse testing with low duty is used.
28. These parameters, although guaranteed, are not 100% tested in production.

Electrical Characteristics (KA7812AE) (Continued)Refer to the test circuits. $0^{\circ}\text{C} < T_J < +125^{\circ}\text{C}$, $I_O = 1\text{A}$, $V_I = 19\text{V}$, $C_I = 0.33\mu\text{F}$, $C_O = 0.1\mu\text{F}$, unless otherwise specified.

Symbol	Parameter	Conditions	KA7812AE			Unit
			Min.	Typ.	Max.	
V_O	Output Voltage	$T_J = +25^{\circ}\text{C}$	11.75	12	12.25	V
		$I_O = 5\text{mA to } 1\text{A}$, $P_O \leq 15\text{W}$ $V_I = 14.8\text{V to } 27\text{V}$	11.5	12	12.5	
Regline	Line Regulation ⁽²⁹⁾	$V_I = 14.8\text{V to } 30\text{V}$, $I_O = 500\text{mA}$	–	10	120	mV
		$V_I = 16\text{V to } 22\text{V}$	–	4	120	
		$T_J = +25^{\circ}\text{C}$, $V_I = 14.5\text{V to } 27\text{V}$	–	10	120	
		$V_I = 16\text{V to } 22\text{V}$	–	3	60	
Regload	Load Regulation ⁽²⁹⁾	$T_J = +25^{\circ}\text{C}$, $I_O = 5\text{mA to } 1.5\text{A}$	–	12	100	mV
		$I_O = 5\text{mA to } 1.0\text{A}$	–	12	100	
		$I_O = 250\text{mA to } 750\text{mA}$	–	5	50	
I_Q	Quiescent Current	$T_J = +25^{\circ}\text{C}$	–	5.1	6.0	mA
ΔI_Q	Quiescent Current Change	$V_I = 15\text{V to } 30\text{V}$, $T_J = +25^{\circ}\text{C}$	–	–	0.8	mA
		$V_I = 14\text{V to } 27\text{V}$, $I_O = 500\text{mA}$	–	–	0.8	
		$I_O = 5\text{mA to } 1.0\text{A}$	–	–	0.5	
$\Delta V/\Delta T$	Output Voltage Drift ⁽³⁰⁾	$I_O = 5\text{mA}$	–	-1.0	–	mV/ $^{\circ}\text{C}$
V_N	Output Noise Voltage	$f = 10\text{Hz to } 100\text{kHz}$, $T_A = +25^{\circ}\text{C}$	–	10	–	$\mu\text{V}/V_O$
RR	Ripple Rejection ⁽³⁰⁾	$f = 120\text{Hz}$, $I_O = 500\text{mA}$ $V_I = 14\text{V to } 24\text{V}$	–	60	–	dB
V_{Drop}	Dropout Voltage	$I_O = 1\text{A}$, $T_J = +25^{\circ}\text{C}$	–	2.0	–	V
r_O	Output Resistance ⁽³⁰⁾	$f = 1\text{kHz}$	–	18	–	m Ω
I_{SC}	Short Circuit Current	$V_I = 35\text{V}$, $T_A = +25^{\circ}\text{C}$	–	250	–	mA
I_{PK}	Peak Current ⁽³⁰⁾	$T_J = +25^{\circ}\text{C}$	–	2.2	–	A

Notes:

29. Load and line regulation are specified at constant junction temperature. Change in V_O due to heating effects must be taken into account separately. Pulse testing with low duty is used.

30. These parameters, although guaranteed, are not 100% tested in production.

Electrical Characteristics (KA7815AE) (Continued)Refer to the test circuits. $0^{\circ}\text{C} < T_J < +125^{\circ}\text{C}$, $I_O = 1\text{A}$, $V_I = 23\text{V}$, $C_I = 0.33\mu\text{F}$, $C_O = 0.1\mu\text{F}$, unless otherwise specified.

Symbol	Parameter	Conditions	KA7815AE			Unit
			Min.	Typ.	Max.	
V_O	Output Voltage	$T_J = +25^{\circ}\text{C}$	14.7	15	15.3	V
		$I_O = 5\text{mA to } 1\text{A}$, $P_O \leq 15\text{W}$ $V_I = 17.7\text{V to } 30\text{V}$	14.4	15	15.6	
Regline	Line Regulation ⁽³¹⁾	$V_I = 17.9\text{V to } 30\text{V}$, $I_O = 500\text{mA}$	–	10	150	mV
		$V_I = 20\text{V to } 26\text{V}$	–	5	150	
		$T_J = +25^{\circ}\text{C}$ $V_I = 17.5\text{V to } 30\text{V}$	–	11	150	
		$V_I = 20\text{V to } 26\text{V}$	–	3	75	
Regload	Load Regulation ⁽³¹⁾	$T_J = +25^{\circ}\text{C}$, $I_O = 5\text{mA to } 1.5\text{A}$	–	12	100	mV
		$I_O = 5\text{mA to } 1.0\text{A}$	–	12	100	
		$I_O = 250\text{mA to } 750\text{mA}$	–	5	50	
I_Q	Quiescent Current	$T_J = +25^{\circ}\text{C}$	–	5.2	6.0	mA
ΔI_Q	Quiescent Current Change	$V_I = 17.5\text{V to } 30\text{V}$, $T_J = +25^{\circ}\text{C}$	–	–	0.8	mA
		$V_I = 17.5\text{V to } 30\text{V}$, $I_O = 500\text{mA}$	–	–	0.8	
		$I_O = 5\text{mA to } 1.0\text{A}$	–	–	0.5	
$\Delta V/\Delta T$	Output Voltage Drift ⁽³²⁾	$I_O = 5\text{mA}$	–	-1.0	–	mV/ $^{\circ}\text{C}$
V_N	Output Noise Voltage	$f = 10\text{Hz to } 100\text{kHz}$, $T_A = +25^{\circ}\text{C}$	–	10	–	$\mu\text{V}/V_o$
RR	Ripple Rejection ⁽³²⁾	$f = 120\text{Hz}$, $I_O = 500\text{mA}$ $V_I = 18.5\text{V to } 28.5\text{V}$	–	58	–	dB
V_{Drop}	Dropout Voltage	$I_O = 1\text{A}$, $T_J = +25^{\circ}\text{C}$	–	2.0	–	V
r_O	Output Resistance ⁽³²⁾	$f = 1\text{kHz}$	–	19	–	m Ω
I_{SC}	Short Circuit Current	$V_I = 35\text{V}$, $T_A = +25^{\circ}\text{C}$	–	250	–	mA
I_{PK}	Peak Current ⁽³²⁾	$T_J = +25^{\circ}\text{C}$	–	2.2	–	A

Notes:

31. Load and line regulation are specified at constant junction temperature. Change in V_O due to heating effects must be taken into account separately. Pulse testing with low duty is used.
32. These parameters, although guaranteed, are not 100% tested in production.

Electrical Characteristics (KA7818AE) (Continued)Refer to the test circuits. $0^{\circ}\text{C} < T_J < +125^{\circ}\text{C}$, $I_O = 1\text{A}$, $V_I = 27\text{V}$, $C_I = 0.33\mu\text{F}$, $C_O = 0.1\mu\text{F}$, unless otherwise specified.

Symbol	Parameter	Conditions	KA7818AE			Unit	
			Min.	Typ.	Max.		
V_O	Output Voltage	$T_J = +25^{\circ}\text{C}$	17.64	18	18.36	V	
		$I_O = 5\text{mA to } 1\text{A}$, $P_O \leq 15\text{W}$ $V_I = 21\text{V to } 33\text{V}$	17.3	18	18.7		
Regline	Line Regulation ⁽³³⁾	$V_I = 21\text{V to } 33\text{V}$, $I_O = 500\text{mA}$	–	15	180	mV	
		$V_I = 21\text{V to } 33\text{V}$	–	5	180		
		$T_J = +25^{\circ}\text{C}$	$V_I = 20.6\text{V to } 33\text{V}$	–	15		180
			$V_I = 24\text{V to } 30\text{V}$	–	5		90
Regload	Load Regulation ⁽³³⁾	$T_J = +25^{\circ}\text{C}$, $I_O = 5\text{mA to } 1.5\text{A}$	–	15	100	mV	
		$I_O = 5\text{mA to } 1.0\text{A}$	–	15	100		
		$I_O = 250\text{mA to } 750\text{mA}$	–	7	50		
I_Q	Quiescent Current	$T_J = +25^{\circ}\text{C}$	–	5.2	6.0	mA	
ΔI_Q	Quiescent Current Change	$V_I = 21\text{V to } 33\text{V}$, $T_J = +25^{\circ}\text{C}$	–	–	0.8	mA	
		$V_I = 21\text{V to } 33\text{V}$, $I_O = 500\text{mA}$	–	–	0.8		
		$I_O = 5\text{mA to } 1.0\text{A}$	–	–	0.5		
$\Delta V/\Delta T$	Output Voltage Drift ⁽³⁴⁾	$I_O = 5\text{mA}$	–	-1.0	–	mV/ $^{\circ}\text{C}$	
V_N	Output Noise Voltage	$f = 10\text{Hz to } 100\text{kHz}$, $T_A = +25^{\circ}\text{C}$	–	10	–	$\mu\text{V}/V_O$	
RR	Ripple Rejection ⁽³⁴⁾	$f = 120\text{Hz}$, $I_O = 500\text{mA}$ $V_I = 22\text{V to } 32\text{V}$	–	57	–	dB	
V_{Drop}	Dropout Voltage	$I_O = 1\text{A}$, $T_J = +25^{\circ}\text{C}$	–	2.0	–	V	
r_O	Output Resistance ⁽³⁴⁾	$f = 1\text{kHz}$	–	19	–	m Ω	
I_{SC}	Short Circuit Current	$V_I = 35\text{V}$, $T_A = +25^{\circ}\text{C}$	–	250	–	mA	
I_{PK}	Peak Current ⁽³⁴⁾	$T_J = +25^{\circ}\text{C}$	–	2.2	–	A	

Notes:

33. Load and line regulation are specified at constant junction temperature. Change in V_O due to heating effects must be taken into account separately. Pulse testing with low duty is used.
34. These parameters, although guaranteed, are not 100% tested in production.

Electrical Characteristics (KA7824AE) (Continued)Refer to the test circuits. $0^{\circ}\text{C} < T_J < +125^{\circ}\text{C}$, $I_O = 1\text{A}$, $V_I = 33\text{V}$, $C_I = 0.33\mu\text{F}$, $C_O = 0.1\mu\text{F}$, unless otherwise specified.

Symbol	Parameter	Conditions	KA7824AE			Unit	
			Min.	Typ.	Max.		
V_O	Output Voltage	$T_J = +25^{\circ}\text{C}$	23.5	24	24.5	V	
		$I_O = 5\text{mA to } 1\text{A}$, $P_O \leq 15\text{W}$ $V_I = 27.3\text{V to } 38\text{V}$	23	24	25		
Regline	Line Regulation ⁽³⁵⁾	$V_I = 27\text{V to } 38\text{V}$, $I_O = 500\text{mA}$	–	18	240	mV	
		$V_I = 21\text{V to } 33\text{V}$	–	6	240		
		$T_J = +25^{\circ}\text{C}$	$V_I = 26.7\text{V to } 38\text{V}$ $V_I = 30\text{V to } 36\text{V}$	–	18		240
		–		6	120		
Regload	Load Regulation ⁽³⁵⁾	$T_J = +25^{\circ}\text{C}$, $I_O = 5\text{mA to } 1.5\text{A}$	–	15	100	mV	
		$I_O = 5\text{mA to } 1.0\text{A}$	–	15	100		
		$I_O = 250\text{mA to } 750\text{mA}$	–	7	50		
I_Q	Quiescent Current	$T_J = +25^{\circ}\text{C}$	–	5.2	6.0	mA	
ΔI_Q	Quiescent Current Change	$V_I = 27.3\text{V to } 38\text{V}$, $T_J = +25^{\circ}\text{C}$	–	–	0.8	mA	
		$V_I = 27.3\text{V to } 38\text{V}$, $I_O = 500\text{mA}$	–	–	0.8		
		$I_O = 5\text{mA to } 1.0\text{A}$	–	–	0.5		
$\Delta V/\Delta T$	Output Voltage Drift ⁽³⁶⁾	$I_O = 5\text{mA}$	–	-1.5	–	mV/ $^{\circ}\text{C}$	
V_N	Output Noise Voltage	$f = 10\text{Hz to } 100\text{kHz}$, $T_A = 25^{\circ}\text{C}$	–	10	–	$\mu\text{V}/V_O$	
RR	Ripple Rejection ⁽³⁶⁾	$f = 120\text{Hz}$, $I_O = 500\text{mA}$ $V_I = 28\text{V to } 38\text{V}$	–	54	–	dB	
V_{Drop}	Dropout Voltage	$I_O = 1\text{A}$, $T_J = +25^{\circ}\text{C}$	–	2.0	–	V	
r_O	Output Resistance ⁽³⁶⁾	$f = 1\text{kHz}$	–	20	–	m Ω	
I_{SC}	Short Circuit Current	$V_I = 35\text{V}$, $T_A = +25^{\circ}\text{C}$	–	250	–	mA	
I_{PK}	Peak Current ⁽³⁶⁾	$T_J = +25^{\circ}\text{C}$	–	2.2	–	A	

Notes:

35. Load and line regulation are specified at constant junction temperature. Change in V_O due to heating effects must be taken into account separately. Pulse testing with low duty is used.
36. These parameters, although guaranteed, are not 100% tested in production.

Typical Performance Characteristics

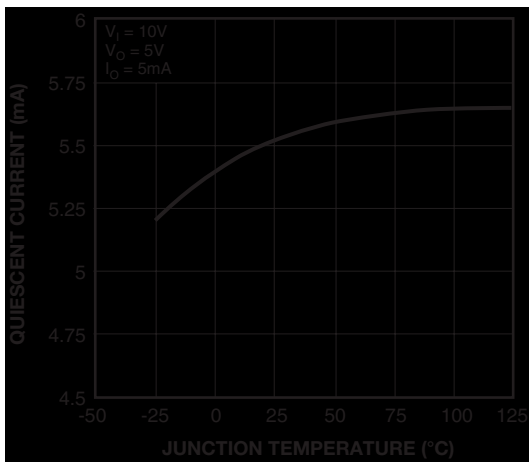

Figure 3. Quiescent Current

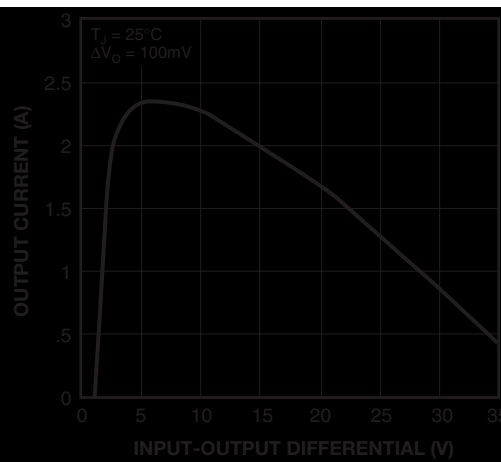

Figure 4. Output Voltage

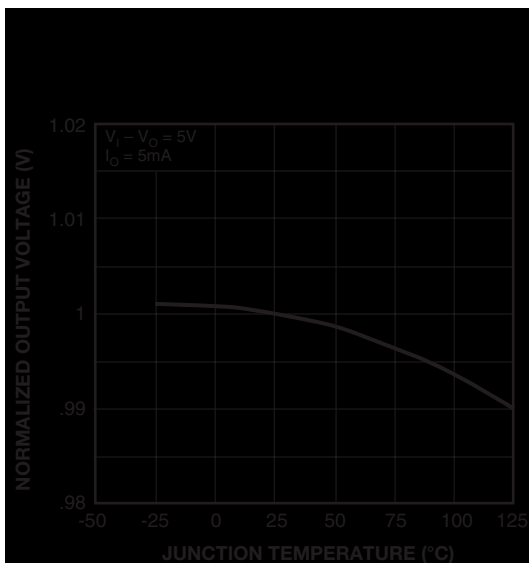

Figure 5. Peak Output Current

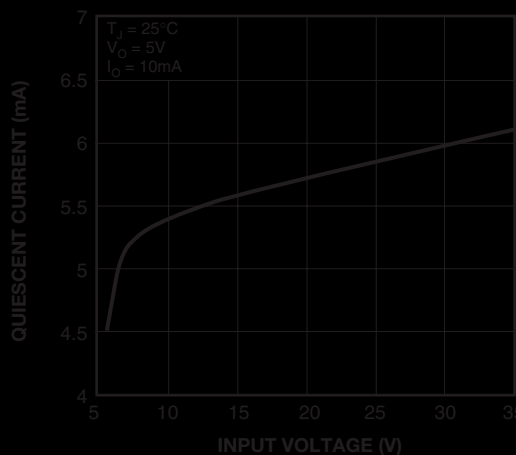

Figure 6. Quiescent Current

Typical Applications

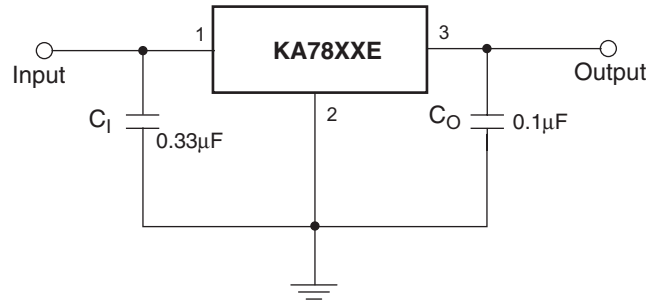

Figure 7. DC Parameters

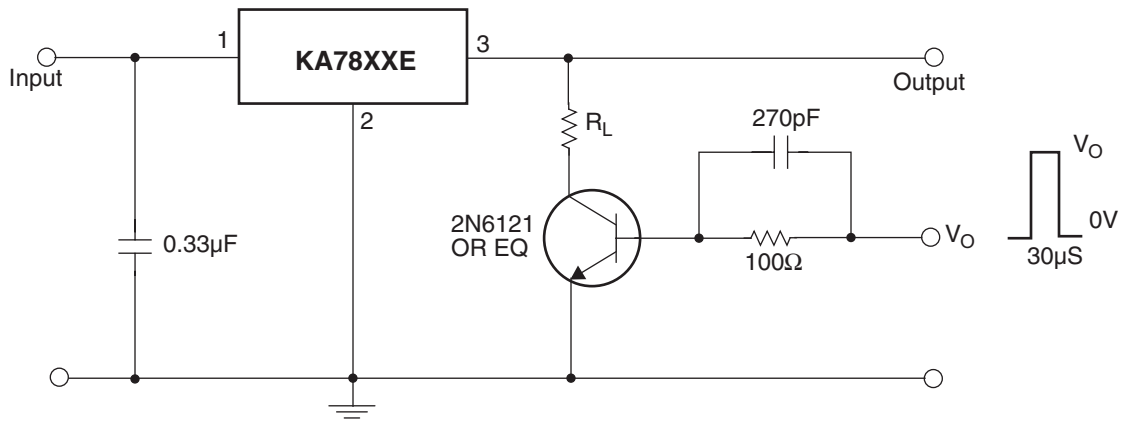

Figure 8. Load Regulation

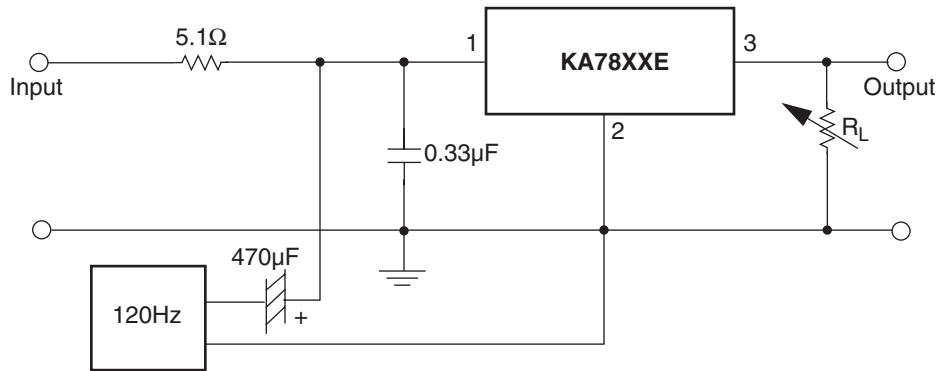

Figure 9. Ripple Rejection

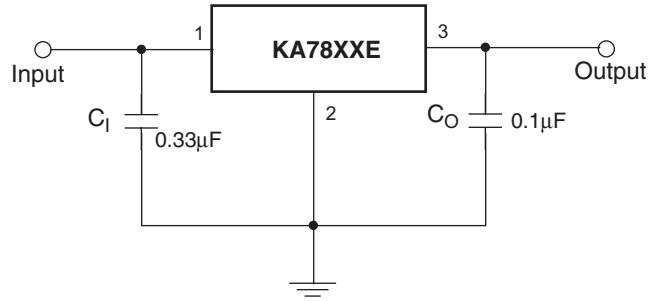

Figure 10. Fixed Output Regulator

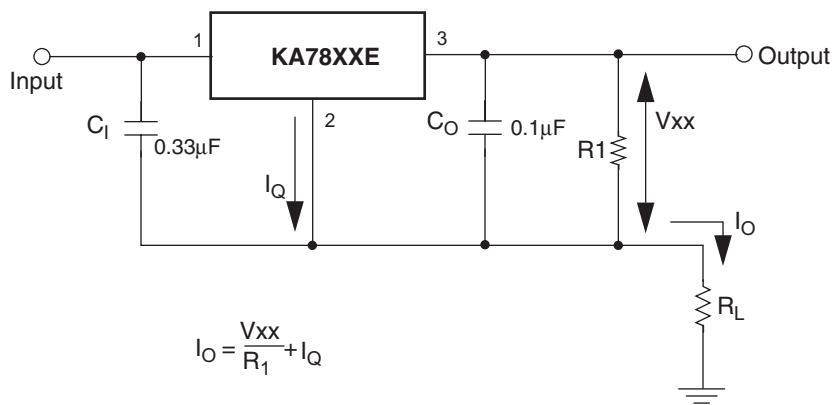

Figure 11. Constant Current Regulator

Notes:

1. To specify an output voltage, substitute voltage value for "XX." A common ground is required between the input and the Output voltage. The input voltage must remain typically 2.0V above the output voltage even during the low point on the input ripple voltage.
2. C₁ is required if regulator is located an appreciable distance from power Supply filter.
3. C₀ improves stability and transient response.

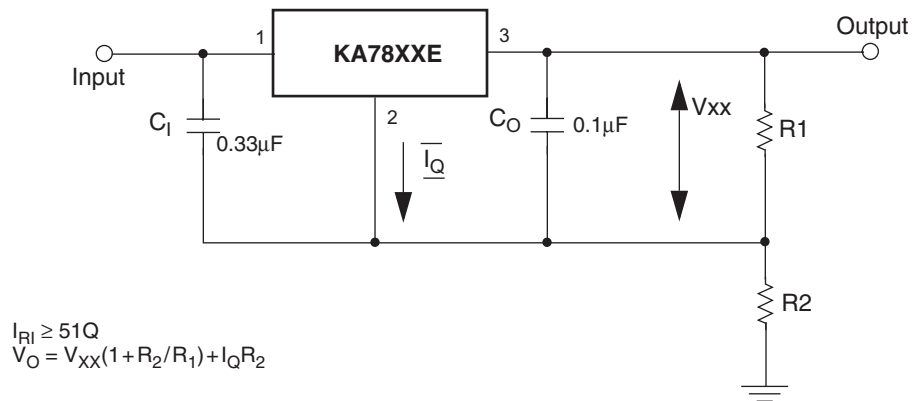

Figure 12. Circuit for Increasing Output Voltage

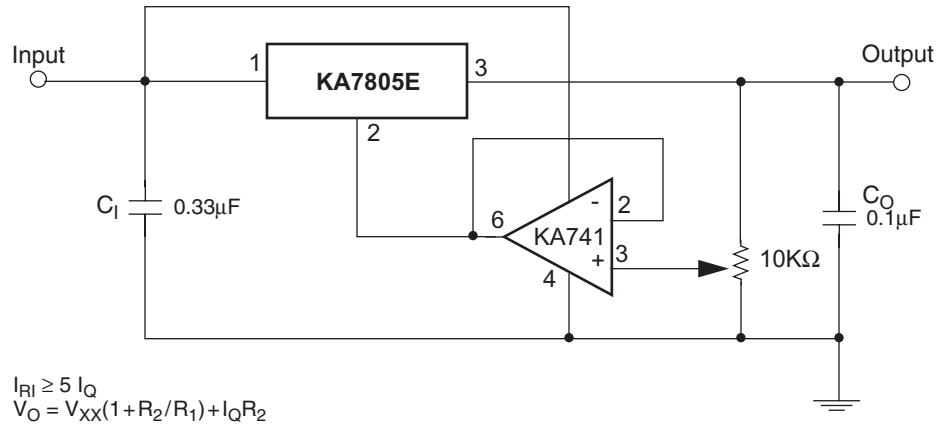

Figure 13. Adjustable Output Regulator (7 to 30V)

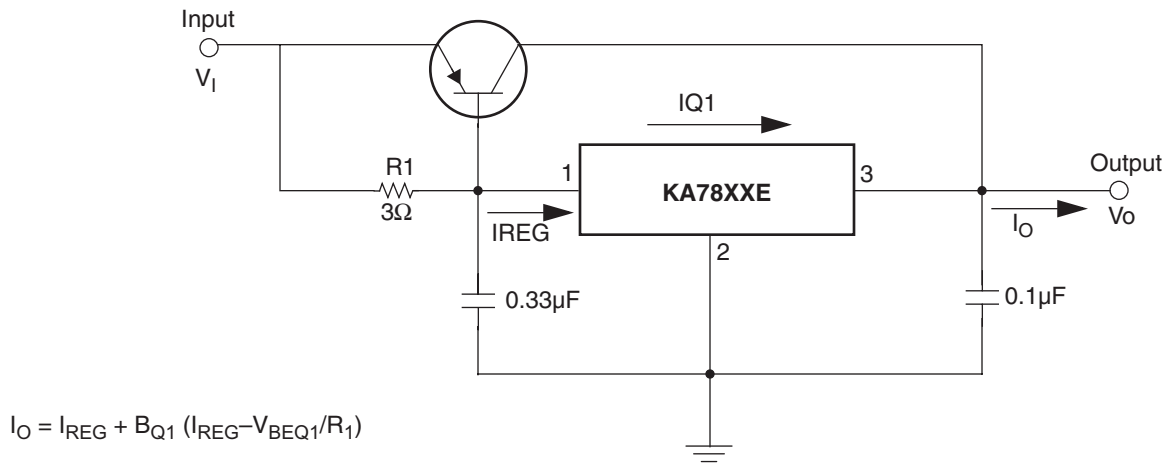

Figure 14. High Current Voltage Regulator

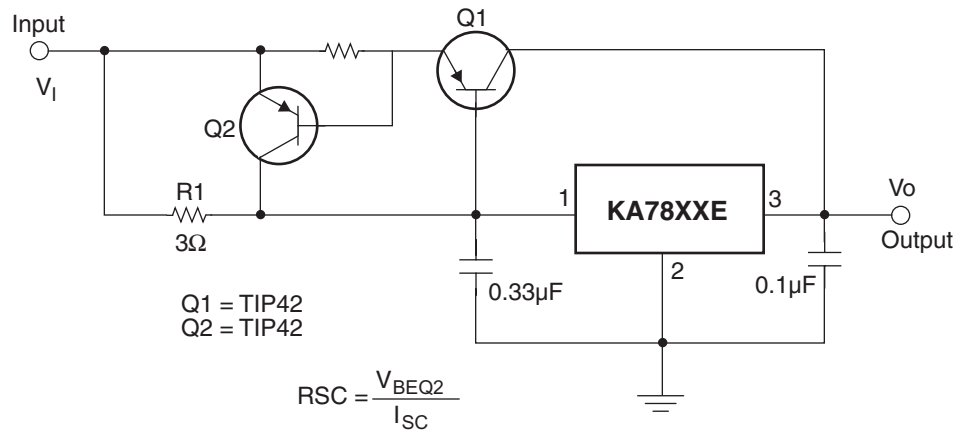

Figure 15. High Output Current with Short Circuit Protection

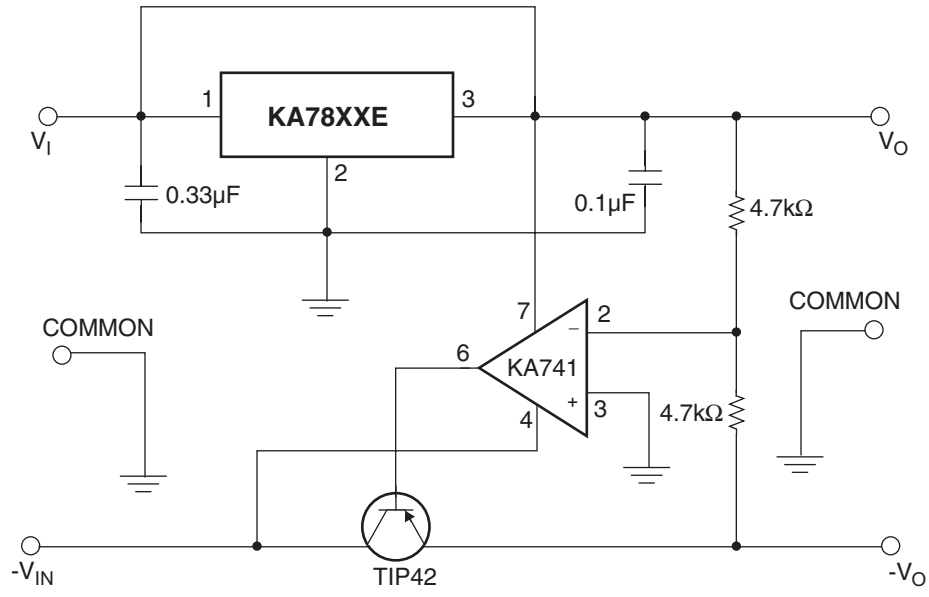

Figure 16. Tracking Voltage Regulator

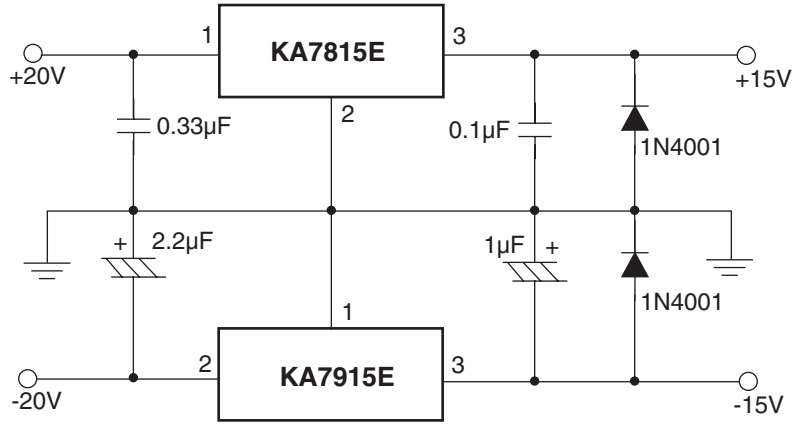

Figure 17. Split Power Supply (±15V-1A)

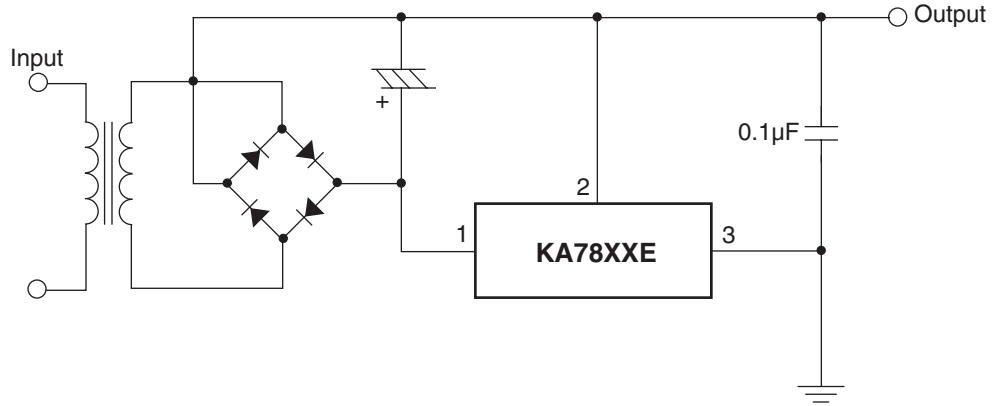

Figure 18. Negative Output Voltage Circuit

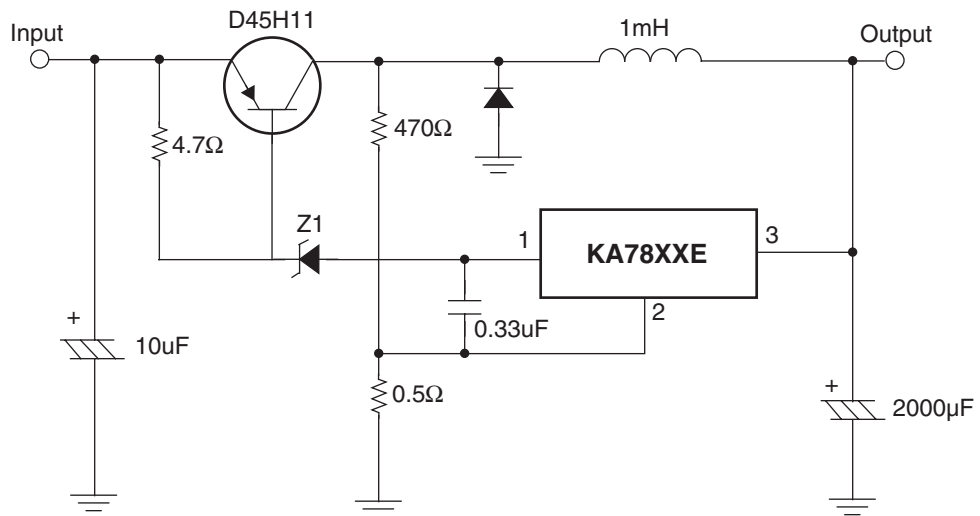
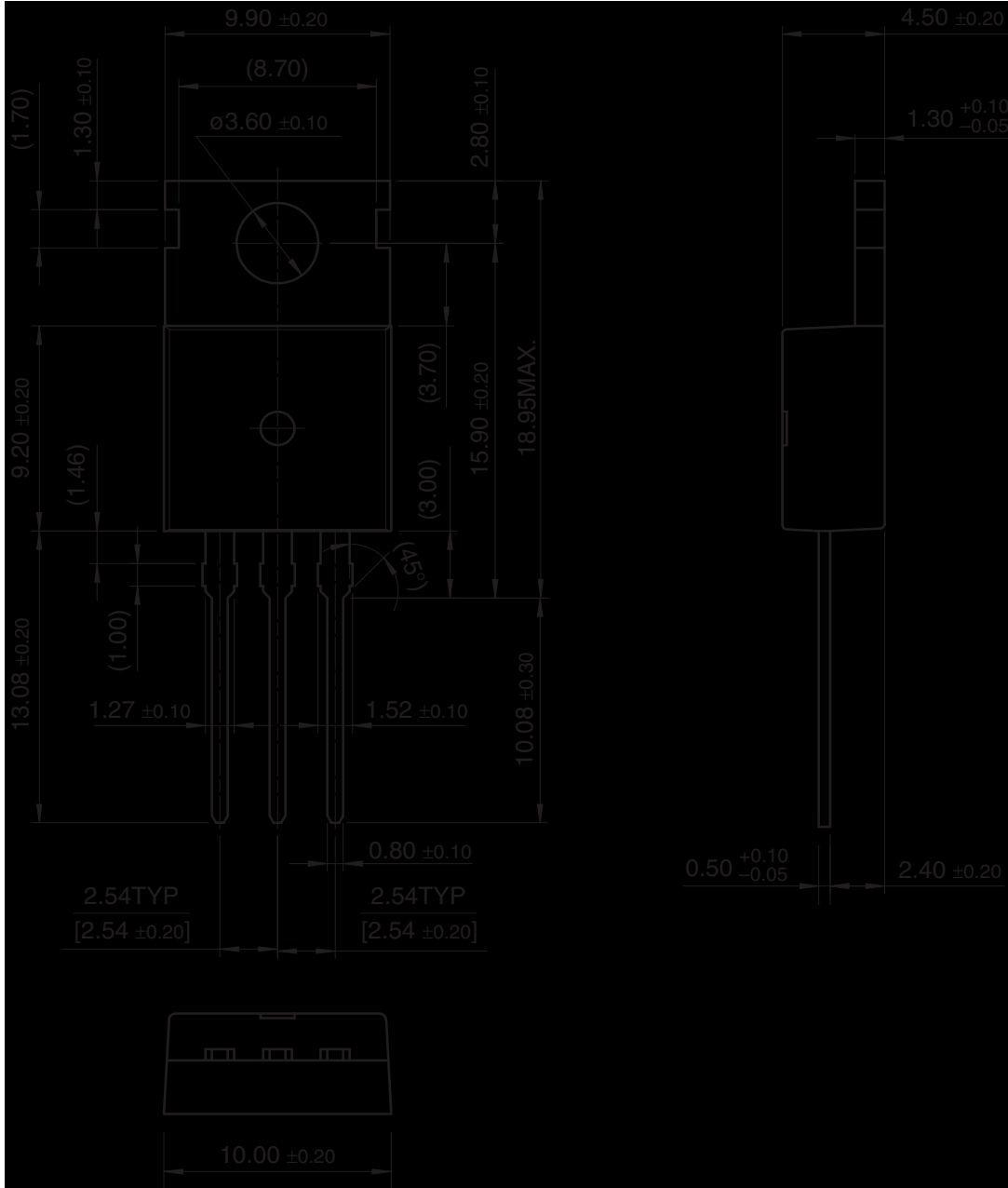

Figure 19. Switching Regulator

Mechanical Dimensions

Dimensions in millimeters

TO-220





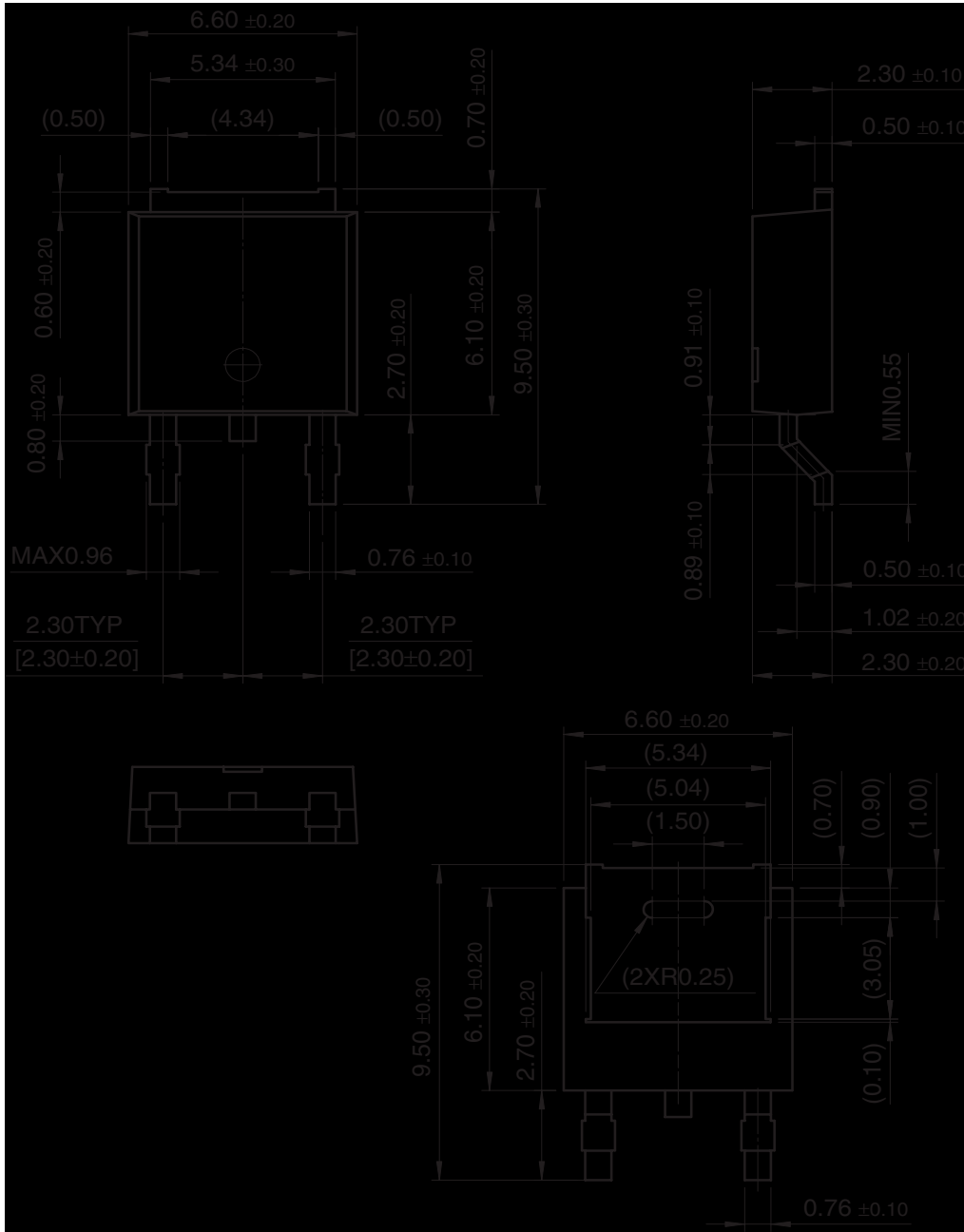

Mechanical Dimensions (Continued)

Dimensions in millimeters

D-PAK





KA7809ERTF	Full Production	 Full Production	\$0.454	TO-252(DPAK)	2	TAPE REEL	Line 1: KA78
KA7809ERTM	Full Production	 Full Production	\$0.454	TO-252(DPAK)	2	TAPE REEL	Line 1: KA78 Line 2: 09R Line 3: E&E&3
KA7809ETSTU	Full Production	 Full Production	\$0.386	TO-220	3	RAIL	N/A
KA7809ETU	Full Production	 Full Production	\$0.386	TO-220	3	RAIL	Line 1: \$Y (Fairchild logo)

* Fairchild 1,000 piece Budgetary Pricing

** A sample button will appear if the part is available through Fairchild's on-line samples program. If there is no sample button, please contact a [Fairchild distributor](#) to obtain samples



Indicates product with Pb-free second-level interconnect. For more information [click here](#).

Package marking information for product KA7809E is available. [Click here for more information](#).

[back to top](#)

Qualification Support

Click on a product for detailed qualification data

Product
KA7809ERTF
KA7809ERTM
KA7809ETSTU
KA7809ETU

[back to top](#)

© 2007 Fairchild Semiconductor

