

NLSX3012

2-Bit 100 Mb/s Configurable Dual-Supply Level Translator

The NLSX3012 is a 2-bit configurable dual-supply bidirectional level translator without a direction control pin. The I/O V_{CC} - and I/O V_L -ports are designed to track two different power supply rails, V_{CC} and V_L respectively. The V_{CC} supply rail is configurable from 1.3 V to 4.5 V while the V_L supply rail is configurable from 0.9 V to ($V_{CC} - 0.4$) V. This allows lower voltage logic signals on the V_L side to be translated into higher voltage logic signals on the V_{CC} side, and vice-versa. Both I/O ports are auto-sensing; thus, no direction pin is required.

The Output Enable (EN) input, when Low, disables both I/O ports by putting them in 3-state. This significantly reduces the supply currents from both V_{CC} and V_L . The EN signal is designed to track V_L .

Features

- Wide High-Side V_{CC} Operating Range: 1.3 V to 4.5 V
Wide Low-Side V_L Operating Range: 0.9 V to ($V_{CC} - 0.4$) V
- High-Speed with 140 Mb/s Guaranteed Data Rate for $V_L > 1.8$ V
- Low Bit-to-Bit Skew
- Overvoltage Tolerant Enable and I/O Pins
- Non-preferential Powerup Sequencing
- Small packaging: UDFN8, SO-8, Micro8
- These are Pb-Free Devices

Typical Applications

- Mobile Phones, PDAs, Other Portable Devices
- PC and Laptops



ON Semiconductor®

<http://onsemi.com>

MARKING DIAGRAMS



UDFN8
MU SUFFIX
CASE 517AJ

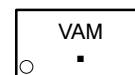

- VA = Specific Device Code
- M = Date Code
- = Pb-Free Package



SO-8
D SUFFIX
CASE 751

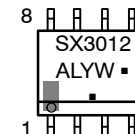

- A = Assembly Location
- L = Wafer Lot
- Y = Year
- W = Work Week
- = Pb-Free Package



Micro8
DM SUFFIX
CASE 846A

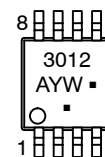

- A = Assembly Location
- Y = Year
- W = Work Week
- = Pb-Free Package

ORDERING INFORMATION

| Device | Package | Shipping† |
|---------------|---------------------|------------------|
| NLSX3012MUTAG | UDFN8 (Pb-Free) | 3000/Tape & Reel |
| NLSX3012DR2G | SO-8 (Pb-Free) | 2500/Tape & Reel |
| NLSX3012DMR2G | Micro8 (Pb-Free) | 4000/Tape & Reel |

†For information on tape and reel specifications, including part orientation and tape sizes, please refer to our Tape and Reel Packaging Specification Brochure, BRD8011/D.

NLSX3012

LOGIC DIAGRAM

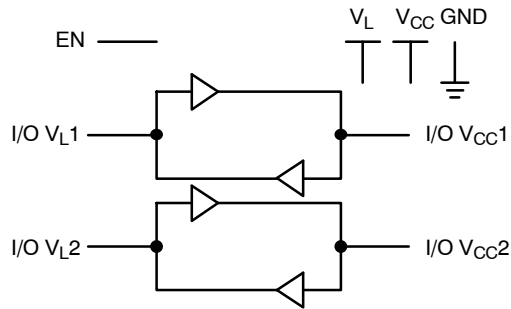

PIN ASSIGNMENTS

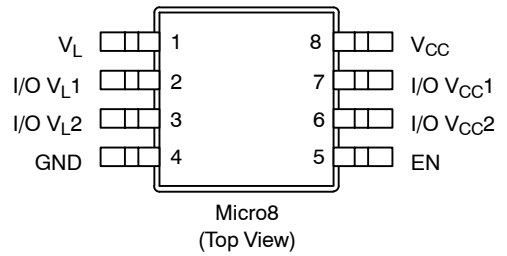
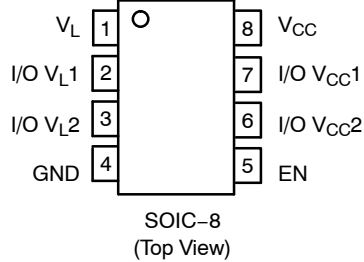
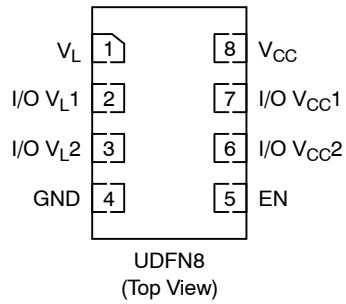

PIN ASSIGNMENT

| Pins | Description |
|----------------------|---|
| V _{CC} | V _{CC} Input Voltage |
| V _L | V _L Input Voltage |
| GND | Ground |
| EN | Output Enable |
| I/O V _{CCn} | I/O Port, Referenced to V _{CC} |
| I/O V _{Ln} | I/O Port, Referenced to V _L |

FUNCTION TABLE

| EN | Operating Mode |
|----|---------------------|
| L | Hi-Z |
| H | I/O Buses Connected |

NLSX3012

MAXIMUM RATINGS

| Symbol | Parameter | Value | Condition | Unit |
|--------------|--|----------------------------|-------------|-------------|
| V_{CC} | V_{CC} Supply Voltage | -0.5 to +5.5 | | V |
| V_L | V_L Supply Voltage | -0.5 to +5.5 | | V |
| I/O V_{CC} | V_{CC} -Referenced DC Input/Output Voltage | -0.5 to ($V_{CC} + 0.3$) | | V |
| I/O V_L | V_L -Referenced DC Input/Output Voltage | -0.5 to ($V_L + 0.3$) | | V |
| V_{EN} | Enable Control Pin DC Input Voltage | -0.5 to +5.5 | | V |
| I_{IK} | Input Diode Clamp Current | -50 | $V_I < GND$ | mA |
| I_{OK} | Output Diode Clamp Current | -50 | $V_O < GND$ | mA |
| I_{CC} | DC Supply Current Through V_{CC} | ± 100 | | mA |
| I_L | DC Supply Current Through V_L | ± 100 | | mA |
| I_{GND} | DC Ground Current Through Ground Pin | ± 100 | | mA |
| T_{STG} | Storage Temperature | -65 to +150 | | $^{\circ}C$ |

Stresses exceeding Maximum Ratings may damage the device. Maximum Ratings are stress ratings only. Functional operation above the Recommended Operating Conditions is not implied. Extended exposure to stresses above the Recommended Operating Conditions may affect device reliability.

RECOMMENDED OPERATING CONDITIONS

| Symbol | Parameter | Min | Max | Unit |
|---------------------|---|---------------------------|----------------|-------------|
| V_{CC} | V_{CC} Supply Voltage | 1.3 | 4.5 | V |
| V_L | V_L Supply Voltage | 0.9 | $V_{CC} - 0.4$ | V |
| V_{EN} | Enable Control Pin Voltage | GND | 4.5 | V |
| V_{IO} | Bus Input/Output Voltage | I/O V_{CC} I/O V_L | 4.5 4.5 | V |
| T_A | Operating Temperature Range | -40 | +85 | $^{\circ}C$ |
| $\Delta I/\Delta V$ | Input Transition Rise or Rate V_I, V_{IO} from 30% to 70% of V_{CC} ; $V_{CC} = 3.3 V \pm 0.3 V$ | 0 | 10 | ns |

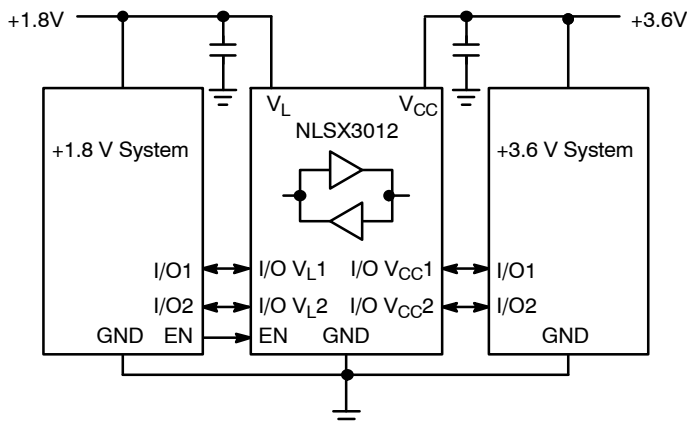

Figure 1. Typical Application Circuit

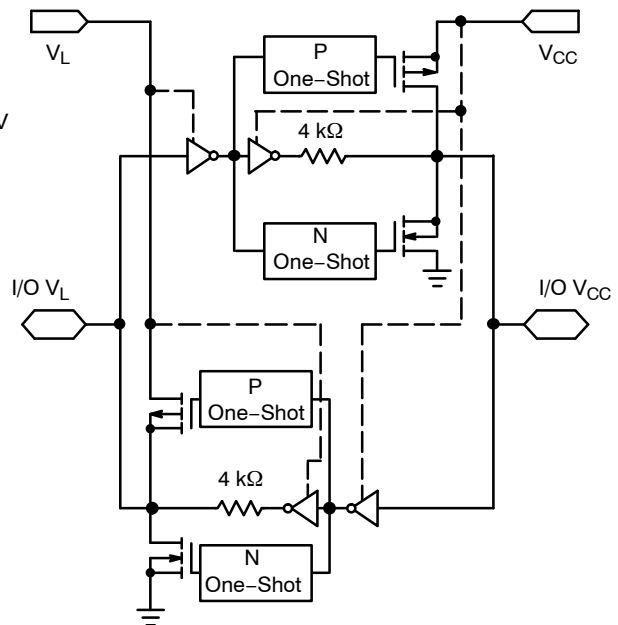

Figure 2. Simplified Functional Diagram (1 I/O Line)
(EN = 1)

NLSX3012

DC ELECTRICAL CHARACTERISTICS

| Symbol | Parameter | Test Conditions (Note 1) | V _{CC} (V) (Note 2) | V _L (V) (Note 3) | -40°C to +85°C | | | Unit |
|------------------|---|--|---------------------------------|--------------------------------|-----------------------|-----------------|-----------------------|------|
| | | | | | Min | Typ (Note 4) | Max | |
| V _{IHC} | I/O V _{CC} Input HIGH Voltage | | 1.3 to 4.5 | 0.9 to (V _{CC} - 0.4) | 0.8 * V _{CC} | - | - | V |
| V _{ILC} | I/O V _{CC} Input LOW Voltage | | 1.3 to 4.5 | 0.9 to (V _{CC} - 0.4) | - | - | 0.2 * V _{CC} | V |
| V _{IHL} | I/O V _L Input HIGH Voltage | | 1.3 to 4.5 | 0.9 to (V _{CC} - 0.4) | 0.8 * V _L | - | - | V |
| V _{ILL} | I/O V _L Input LOW Voltage | | 1.3 to 4.5 | 0.9 to (V _{CC} - 0.4) | - | - | 0.2 * V _L | V |
| V _{IH} | Control Pin Input HIGH Voltage | T _A = +25°C | 1.3 to 4.5 | 0.9 to (V _{CC} - 0.4) | 0.8 * V _L | - | - | V |
| V _{IL} | Control Pin Input LOW Voltage | T _A = +25°C | 1.3 to 4.5 | 0.9 to (V _{CC} - 0.4) | - | - | 0.2 * V _L | V |
| V _{OHC} | I/O V _{CC} Output HIGH Voltage | I/O V _{CC} Source Current = 20 μA | 1.3 to 4.5 | 0.9 to (V _{CC} - 0.4) | 0.8 * V _{CC} | - | - | V |
| V _{OLC} | I/O V _{CC} Output LOW Voltage | I/O V _{CC} Sink Current = 20 μA | 1.3 to 4.5 | 0.9 to (V _{CC} - 0.4) | - | - | 0.2 * V _{CC} | V |
| V _{OHL} | I/O V _L Output HIGH Voltage | I/O V _L Source Current = 20 μA | 1.3 to 4.5 | 0.9 to (V _{CC} - 0.4) | 0.8 * V _L | - | - | V |
| V _{OLL} | I/O V _L Output LOW Voltage | I/O V _L Sink Current = 20 μA | 1.3 to 4.5 | 0.9 to (V _{CC} - 0.4) | - | - | 0.2 * V _L | V |

1. Normal test conditions are V_{EN} = 0 V, C_{I0VCC} = 15 pF and C_{I0VL} = 15 pF, unless otherwise specified.
2. V_{CC} is the supply voltage associated with the high voltage port, and V_{CC} ranges from +1.3 V to 4.5 V under normal operating conditions.
3. V_L is the supply voltage associated with the low voltage port. V_L must be less than or equal to (V_{CC} - 0.4) V during normal operation. However, during startup and shutdown conditions, V_L can be greater than (V_{CC} - 0.4) V.
4. Typical values are for V_{CC} = +2.8 V, V_L = +1.8 V and T_A = +25°C. All units are production tested at T_A = +25°C. Limits over the operating temperature range are guaranteed by design.

NLSX3012

POWER CONSUMPTION

| Symbol | Parameter | Test Conditions (Note 5) | V _{CC} (V) (Note 6) | V _L (V) (Note 7) | -40°C to +85°C | | | Unit |
|---------------------|---|---|---------------------------------|--------------------------------|----------------|-----|------|------|
| | | | | | Min | Typ | Max | |
| I _{Q-VCC} | Supply Current from V _{CC} | EN = V _L ; I/O V _{CCn} = 0 V, I/O V _{Ln} = 0 V, I/O V _{CCn} = V _{CC} or I/O V _{Ln} = V _L and I _o = 0 | 1.3 to 3.6 | 0.9 to (V _{CC} - 0.4) | - | - | 1.0 | μA |
| I _{Q-VL} | Supply Current from V _L | EN = V _L ; I/O V _{CCn} = 0 V, I/O V _{Ln} = 0 V, I/O V _{CCn} = V _{CC} or I/O V _{Ln} = V _L and I _o = 0 | 1.3 to 3.6 | 0.9 to (V _{CC} - 0.4) | - | - | 1.0 | μA |
| | | EN = V _L ; I/O V _{CCn} = 0 V, I/O V _{Ln} = 0 V, I/O V _{CCn} = V _{CC} or I/O V _{Ln} = (V _{CC} - 0.2 V) and I _o = 0 | | < (V _{CC} - 0.2) | - | - | 2.0 | |
| I _{TS-VCC} | V _{CC} Tristate Output Mode Supply Current | EN = 0 V | 1.3 to 3.6 | 0.9 to (V _{CC} - 0.4) | - | - | 1.0 | μA |
| I _{TS-VL} | V _L Tristate Output Mode Supply Current | EN = 0 V | 1.3 to 3.6 | 0.9 to (V _{CC} - 0.4) | - | - | 0.2 | μA |
| | | EN = 0 V | | V _{CC} - 0.2 | - | - | 2.0 | |
| I _{OZ} | I/O Tristate Output Mode Leakage Current | EN = 0 V | 1.3 to 3.6 | 0.9 to (V _{CC} - 0.4) | - | - | 0.15 | μA |
| | | EN = 0 V | | V _{CC} - 0.2 | - | - | 2.0 | |
| I _{EN} | Output Enable Pin Input Current | - | 1.3 to 3.6 | 0.9 to (V _{CC} - 0.4) | - | - | 1.0 | μA |

5. Normal test conditions are V_{EN} = 0 V, C_{IOVCC} = 15 pF and C_{IOVL} = 15 pF, unless otherwise specified.

6. V_{CC} is the supply voltage associated with the high voltage port, and V_{CC} ranges from +1.3 V to 4.5 V under normal operating conditions.

7. V_L is the supply voltage associated with the low voltage port. V_L must be less than or equal to (V_{CC} - 0.4) V during normal operation. However, during startup and shutdown conditions, V_L can be greater than (V_{CC} - 0.4) V.

8. Typical values are for V_{CC} = +2.8 V, V_L = +1.8 V and T_A = +25°C. All units are production tested at T_A = +25°C. Limits over the operating temperature range are guaranteed by design.

NLSX3012

TIMING CHARACTERISTICS

| Symbol | Parameter | Test Conditions (Note 9) | V _{CC} (V) (Note 10) | V _L (V) (Note 11) | -40°C to +85°C | | | Unit |
|------------------------|---|--|----------------------------------|---------------------------------|----------------|------------------|-----|------|
| | | | | | Min | Typ (Note 12) | Max | |
| t _{R-VCC} | I/O V _{CC} Rise Time (Output = I/O_V _{CC}) | C _{I_OV_{CC}} = 15 pF | 1.3 to 4.5 | 0.9 to (V _{CC} - 0.4) | | 0.7 | 2.4 | ns |
| t _{F-VCC} | I/O V _{CC} Falltime (Output = I/O_V _{CC}) | C _{I_OV_{CC}} = 15 pF | 1.3 to 4.5 | 0.9 to (V _{CC} - 0.4) | | 0.5 | 1.0 | ns |
| t _{R-VL} | I/O V _L Risetime (Output = I/O_V _L) | C _{I_OV_L} = 15 pF | 1.3 to 4.5 | 0.9 to (V _{CC} - 0.4) | | 1.0 | 3.8 | ns |
| t _{F-VL} | I/O V _L Falltime (Output = I/O_V _L) | C _{I_OV_L} = 15 pF | 1.3 to 4.5 | 0.9 to (V _{CC} - 0.4) | | 0.6 | 1.2 | ns |
| Z _{O-VCC} | I/O V _{CC} One-Shot Output Impedance | | 1.3 to 4.5 | 0.9 to (V _{CC} - 0.4) | | 30 | | Ω |
| Z _{O-VL} | I/O V _L One-Shot Output Impedance | | 1.3 to 4.5 | 0.9 to (V _{CC} - 0.4) | | 30 | | Ω |
| t _{PD_VL-VCC} | Propagation Delay (Output = I/O_V _{CC} , t _{PHL} , t _{PLH}) | C _{I_OV_{CC}} = 15 pF | 1.3 to 4.5 | 0.9 to (V _{CC} - 0.4) | | 4.5 | 12 | ns |
| t _{PD_VCC-VL} | Propagation Delay (Output = I/O_V _L , t _{PHL} , t _{PLH}) | C _{I_OV_L} = 15 pF | 1.3 to 4.5 | 0.9 to (V _{CC} - 0.4) | | 3.0 | 7.2 | ns |
| t _{SK_VL-VCC} | Channel-to-Channel Skew (Output = I/O_V _{CC}) | C _{I_OV_{CC}} = 15 pF | 1.3 to 4.5 | 0.9 to (V _{CC} - 0.4) | | 0.2 | 0.3 | nS |
| t _{SK_VCC-VL} | Channel-to-Channel Skew (Output = I/O_V _L) | C _{I_OV_{CC}} = 15 pF | 1.3 to 4.5 | 0.9 to (V _{CC} - 0.4) | | 0.2 | 0.3 | nS |
| MDR | Maximum Data Rate | (Output = I/O_V _{CC} , C _{I_OV_{CC}} = 15 pF) (Output = I/O_V _L , C _{I_OV_L} = 15 pF) | 1.3 to 4.5 | 0.9 to (V _{CC} - 0.4) | 110 | | | Mb/s |
| | | | > 2.2 | > 1.8 | 140 | | | |

9. Normal test conditions are V_{EN} = 0 V, C_{I_OV_{CC}} = 15 pF and C_{I_OV_L} = 15 pF, unless otherwise specified.

10. V_{CC} is the supply voltage associated with the high voltage port, and V_{CC} ranges from +1.3 V to 4.5 V under normal operating conditions.

11. V_L is the supply voltage associated with the low voltage port. V_L must be less than or equal to (V_{CC} - 0.4) V during normal operation. However, during startup and shutdown conditions, V_L can be greater than (V_{CC} - 0.4) V.

12. Typical values are for V_{CC} = +2.8 V, V_L = +1.8 V and T_A = +25°C. All units are production tested at T_A = +25°C. Limits over the operating temperature range are guaranteed by design.

ENABLE / DISABLE TIME MEASUREMENTS

| Symbol | Parameter | Test Conditions (Note 13) | V _{CC} (V) (Note 14) | V _L (V) (Note 15) | -40°C to +85°C | | | Unit |
|----------------------|--|------------------------------|----------------------------------|---------------------------------|----------------|------------------|-----|------|
| | | | | | Min | Typ (Note 16) | Max | |
| t _{EN-VCC} | Turn-On Enable Time (Output = I/O_V _{CC} , t _{pZH}) | C _{IOVCC} = 15 pF | 1.3 to 4.5 | 0.9 to (V _{CC} - 0.4) | | 150 | 200 | ns |
| | Turn-On Enable Time (Output = I/O_V _{CC} , t _{pZL}) | C _{IOVL} = 15 pF | 1.3 to 4.5 | 0.9 to (V _{CC} - 0.4) | | 130 | 180 | ns |
| t _{EN-VL} | Turn-On Enable Time (Output = I/O_V _L , t _{pZH}) | C _{IOVCC} = 15 pF | 1.3 to 4.5 | 0.9 to (V _{CC} - 0.4) | | 95 | 225 | ns |
| | Turn-On Enable Time (Output = I/O_V _L , t _{pZL}) | C _{IOVL} = 15 pF | 1.3 to 4.5 | 0.9 to (V _{CC} - 0.4) | | 75 | 100 | ns |
| t _{DIS-VCC} | Turn-Off Disable Time (Output = I/O_V _{CC} , t _{pHZ}) | C _{IOVCC} = 15 pF | 1.3 to 4.5 | 0.9 to (V _{CC} - 0.4) | | 175 | 250 | ns |
| | Propagation Delay (Output = I/O_V _{CC} , t _{pLZ}) | C _{IOVL} = 15 pF | 1.3 to 4.5 | 0.9 to (V _{CC} - 0.4) | | 140 | 160 | ns |
| t _{DIS-VL} | Turn-Off Disable Time (Output = I/O_V _L , t _{pHZ}) | C _{IOVCC} = 15 pF | 1.3 to 4.5 | 0.9 to (V _{CC} - 0.4) | | 180 | 275 | ns |
| | Propagation Delay (Output = I/O_V _L , t _{pLZ}) | C _{IOVL} = 15 pF | 1.3 to 4.5 | 0.9 to (V _{CC} - 0.4) | | 160 | 220 | ns |

13. Normal test conditions are V_{EN} = 0 V, C_{IOVCC} = 15 pF and C_{IOVL} = 15 pF, unless otherwise specified.

14. V_{CC} is the supply voltage associated with the high voltage port, and V_{CC} ranges from +1.3 V to 4.5 V under normal operating conditions.

15. V_L is the supply voltage associated with the low voltage port. V_L must be less than or equal to (V_{CC} - 0.4) V during normal operation. However, during startup and shutdown conditions, V_L can be greater than (V_{CC} - 0.4) V.

16. Typical values are for V_{CC} = +2.8 V, V_L = +1.8 V and T_A = +25 °C. All units are production tested at T_A = +25 °C. Limits over the operating temperature range are guaranteed by design.

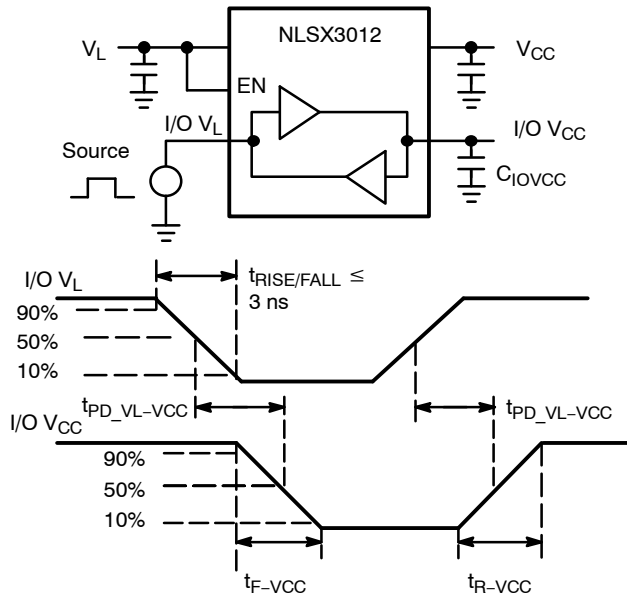

Figure 3. Driving I/O V_L Test Circuit and Timing

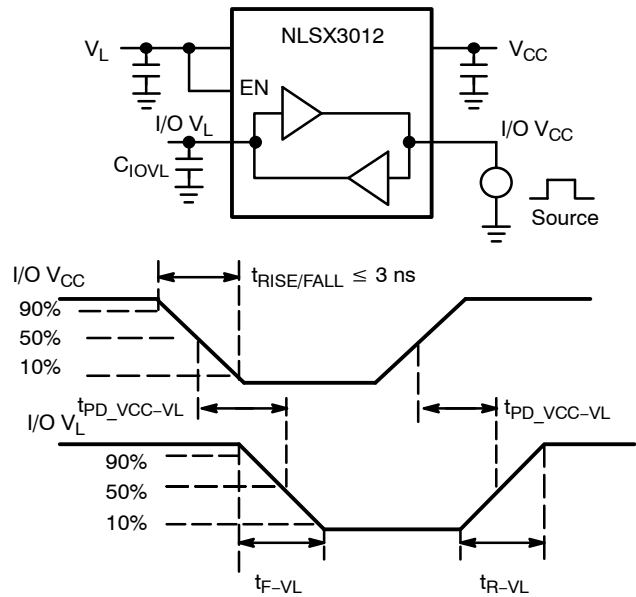
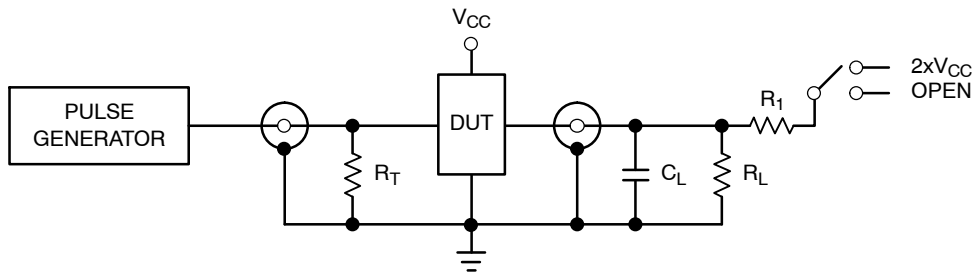

Figure 4. Driving I/O V_{CC} Test Circuit and Timing

NLSX3012



| Test | Switch |
|-----------------------|-------------------|
| t_{PZH} , t_{PHZ} | Open |
| t_{PZL} , t_{PLZ} | $2 \times V_{CC}$ |

$C_L = 15 \text{ pF}$ or equivalent (Includes jig and probe capacitance)
 $R_L = R_1 = 50 \text{ k}\Omega$ or equivalent
 $R_T = Z_{OUT}$ of pulse generator (typically 50Ω)

Figure 5. Test Circuit for Enable/Disable Time Measurement

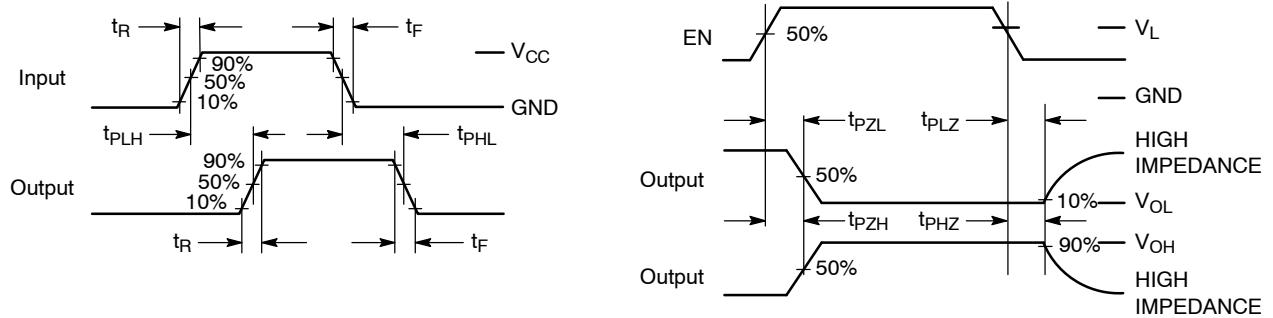

Figure 6. Timing Definitions for Propagation Delays and Enable/Disable Measurement

IMPORTANT APPLICATIONS INFORMATION

Level Translator Architecture

The NLSX3012 auto sense translator provides bi-directional voltage level shifting to transfer data in multiple supply voltage systems. This device has two supply voltages, V_L and V_{CC} , which set the logic levels on the input and output sides of the translator. When used to transfer data from the V_L to the V_{CC} ports, input signals referenced to the V_L supply are translated to output signals with a logic level matched to V_{CC} . In a similar manner, the V_{CC} to V_L translation shifts input signals with a logic level compatible to V_{CC} to an output signal matched to V_L .

The NLSX3012 consists of four bi-directional channels that independently determine the direction of the data flow without requiring a directional pin. The one-shot circuits are used to detect the rising or falling input signals. In addition, the one shots decrease the rise and fall time of the output signal for high-to-low and low-to-high transitions.

Input Driver Requirements

Auto sense translators such as the NLSX3012 have a wide bandwidth, but a relatively small DC output current rating. The high bandwidth of the bi-directional I/O circuit is used to quickly transform from an input to an output driver and vice versa. The I/O ports have a modest DC current output specification so that the output driver can be over driven when data is sent to in the opposite direction.

For proper operation, the input driver to the auto sense translator should be capable of driving 2 mA of peak output current with an output impedance less than 25 Ω . The bi-directional configuration of the translator results in both input stages being active for a very short time period. Although the peak current from the input signal circuit is relatively large, the average current is small and consistent with a standard CMOS input stage.

Output Load Requirements

The NLSX3012 is designed to drive CMOS inputs. Resistive pullup or pulldown loads of less than 50 k Ω should not be used with this device. The NLSX3373 or NLSX3378 open-drain auto sense translators are alternate

translator options for an application such as the I²C bus that requires pullup resistors.

Enable Input (EN)

The NLSX3012 has an Enable pin (EN) that provides tri-state operation at the I/O pins. Driving the Enable pin to a low logic level minimizes the power consumption of the device and drives the I/O V_{CC} and I/O V_L pins to a high impedance state. Normal translation operation occurs when the EN pin is equal to a logic high signal. The EN pin is referenced to the V_L supply and has Over-Voltage Tolerant (OVT) protection.

Uni-Directional versus Bi-Directional Translation

The NLSX3012 can function as a non-inverting uni-directional translator. One advantage of using the translator as a uni-directional device is that each I/O pin can be configured as either an input or output. The configurable input or output feature is especially useful in applications such as SPI that use multiple uni-directional I/O lines to send data to and from a device. The flexible I/O port of the auto sense translator simplifies the trace connections on the PCB.

Power Supply Guidelines

It is recommended that the V_L supply should be less than or equal to the value of the V_{CC} minus 0.4 V. The sequencing of the power supplies will not damage the device during the power up operation; however, the current consumption of the device will increase if V_L exceeds V_{CC} minus 0.4 V. In addition, the I/O V_{CC} and I/O V_L pins are in the high impedance state if either supply voltage is equal to 0 V.

For optimal performance, 0.01 to 0.1 μ F decoupling capacitors should be used on the V_L and V_{CC} power supply pins. Ceramic capacitors are a good design choice to filter and bypass any noise signals on the power supply voltage lines to the ground plane of the PCB. The noise immunity will be maximized by placing the capacitors as close as possible to the supply and ground pins, along with minimizing the PCB connection traces.

MECHANICAL CASE OUTLINE

PACKAGE DIMENSIONS

ON Semiconductor®



SCALE 4:1

UDFN8 1.8x1.2, 0.4P
CASE 517AJ-01
ISSUE O

DATE 08 NOV 2006

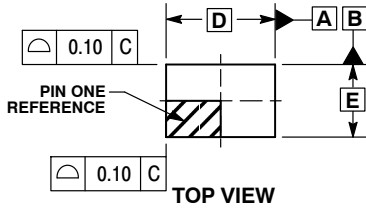

TOP VIEW

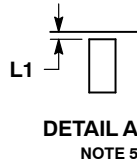

DETAIL A
NOTE 5

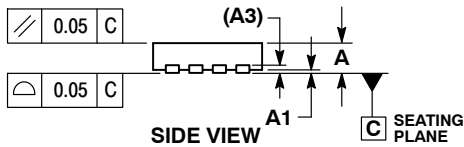

SIDE VIEW

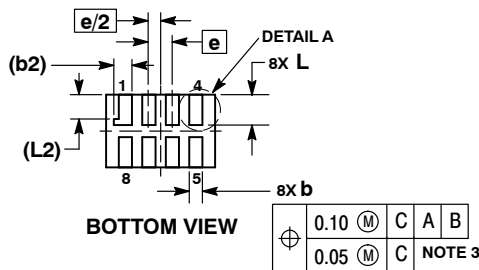

BOTTOM VIEW

| | | | | | |
|---|------|-----|---|---|---|
| ⊕ | 0.10 | (M) | C | A | B |
| | 0.05 | (M) | C | | |

NOTE 3

NOTES:

1. DIMENSIONING AND TOLERANCING PER ASME Y14.5M, 1994.
2. CONTROLLING DIMENSION: MILLIMETERS.
3. DIMENSION b APPLIES TO PLATED TERMINAL AND IS MEASURED BETWEEN 0.15 AND 0.30 mm FROM TERMINAL TIP.
4. MOLD FLASH ALLOWED ON TERMINALS ALONG EDGE OF PACKAGE. FLASH MAY NOT EXCEED 0.03 ONTO BOTTOM SURFACE OF TERMINALS.
5. DETAIL A SHOWS OPTIONAL CONSTRUCTION FOR TERMINALS.

| DIM | MILLIMETERS | |
|-----|-------------|------|
| | MIN | MAX |
| A | 0.45 | 0.55 |
| A1 | 0.00 | 0.05 |
| A3 | 0.127 | REF |
| b | 0.15 | 0.25 |
| b2 | 0.30 | REF |
| D | 1.80 | BSC |
| E | 1.20 | BSC |
| e | 0.40 | BSC |
| L | 0.45 | 0.55 |
| L1 | 0.00 | 0.03 |
| L2 | 0.40 | REF |

GENERIC MARKING DIAGRAM*

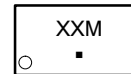

- XX = Specific Device Code
- M = Date Code
- = Pb-Free Package

*This information is generic. Please refer to device data sheet for actual part marking. Pb-Free indicator, "G" or microdot "▪", may or may not be present.

MOUNTING FOOTPRINT
SOLDERMASK DEFINED

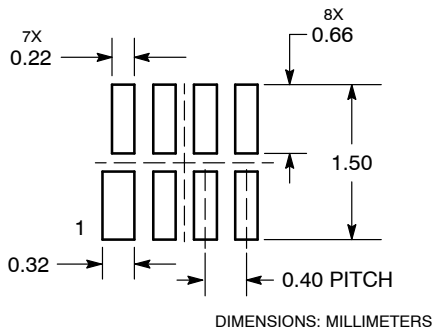

| | | |
|------------------|---------------------|--|
| DOCUMENT NUMBER: | 98AON23417D | Electronic versions are uncontrolled except when accessed directly from the Document Repository. Printed versions are uncontrolled except when stamped "CONTROLLED COPY" in red. |
| DESCRIPTION: | UDFN8 1.8X1.2, 0.4P | PAGE 1 OF 1 |

ON Semiconductor and ON are trademarks of Semiconductor Components Industries, LLC dba ON Semiconductor or its subsidiaries in the United States and/or other countries. ON Semiconductor reserves the right to make changes without further notice to any products herein. ON Semiconductor makes no warranty, representation or guarantee regarding the suitability of its products for any particular purpose, nor does ON Semiconductor assume any liability arising out of the application or use of any product or circuit, and specifically disclaims any and all liability, including without limitation special, consequential or incidental damages. ON Semiconductor does not convey any license under its patent rights nor the rights of others.

MECHANICAL CASE OUTLINE PACKAGE DIMENSIONS

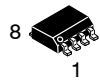

SCALE 1:1

SOIC-8 NB
CASE 751-07
ISSUE AK

DATE 16 FEB 2011

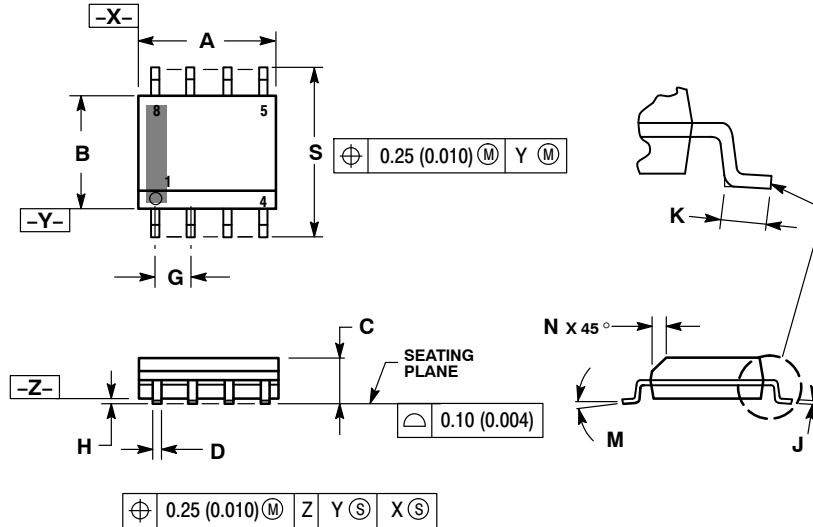

- NOTES:
1. DIMENSIONING AND TOLERANCING PER ANSI Y14.5M, 1982.
 2. CONTROLLING DIMENSION: MILLIMETER.
 3. DIMENSION A AND B DO NOT INCLUDE MOLD PROTRUSION.
 4. MAXIMUM MOLD PROTRUSION 0.15 (0.006) PER SIDE.
 5. DIMENSION D DOES NOT INCLUDE DAMBAR PROTRUSION. ALLOWABLE DAMBAR PROTRUSION SHALL BE 0.127 (0.005) TOTAL IN EXCESS OF THE D DIMENSION AT MAXIMUM MATERIAL CONDITION.
 6. 751-01 THRU 751-06 ARE OBSOLETE. NEW STANDARD IS 751-07.

| DIM | MILLIMETERS | | INCHES | |
|-----|-------------|------|-----------|-------|
| | MIN | MAX | MIN | MAX |
| A | 4.80 | 5.00 | 0.189 | 0.197 |
| B | 3.80 | 4.00 | 0.150 | 0.157 |
| C | 1.35 | 1.75 | 0.053 | 0.069 |
| D | 0.33 | 0.51 | 0.013 | 0.020 |
| G | 1.27 BSC | | 0.050 BSC | |
| H | 0.10 | 0.25 | 0.004 | 0.010 |
| J | 0.19 | 0.25 | 0.007 | 0.010 |
| K | 0.40 | 1.27 | 0.016 | 0.050 |
| M | 0° | 8° | 0° | 8° |
| N | 0.25 | 0.50 | 0.010 | 0.020 |
| S | 5.80 | 6.20 | 0.228 | 0.244 |

SOLDERING FOOTPRINT*

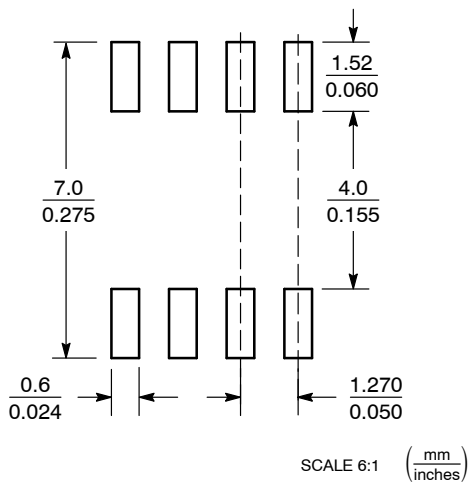

*For additional information on our Pb-Free strategy and soldering details, please download the ON Semiconductor Soldering and Mounting Techniques Reference Manual, SOLDERRM/D.

GENERIC MARKING DIAGRAM*

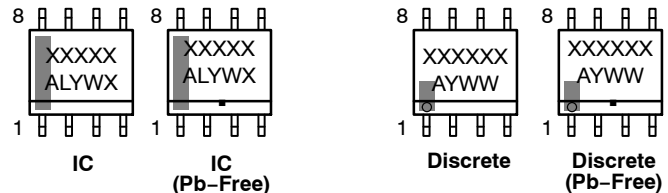

XXXXXX = Specific Device Code
A = Assembly Location
L = Wafer Lot
Y = Year
W = Work Week
▪ = Pb-Free Package

XXXXXX = Specific Device Code
A = Assembly Location
Y = Year
WW = Work Week
▪ = Pb-Free Package

*This information is generic. Please refer to device data sheet for actual part marking. Pb-Free indicator, "G" or microdot "▪", may or may not be present. Some products may not follow the Generic Marking.

STYLES ON PAGE 2

| | | |
|------------------|-------------|--|
| DOCUMENT NUMBER: | 98ASB42564B | Electronic versions are uncontrolled except when accessed directly from the Document Repository. Printed versions are uncontrolled except when stamped "CONTROLLED COPY" in red. |
| DESCRIPTION: | SOIC-8 NB | PAGE 1 OF 2 |

onsemi and ONsemi are trademarks of Semiconductor Components Industries, LLC dba onsemi or its subsidiaries in the United States and/or other countries. onsemi reserves the right to make changes without further notice to any products herein. onsemi makes no warranty, representation or guarantee regarding the suitability of its products for any particular purpose, nor does onsemi assume any liability arising out of the application or use of any product or circuit, and specifically disclaims any and all liability, including without limitation special, consequential or incidental damages. onsemi does not convey any license under its patent rights nor the rights of others.

SOIC-8 NB
CASE 751-07
ISSUE AK

DATE 16 FEB 2011

- | | | | |
|--|---|---|---|
| <p>STYLE 1: PIN 1. EMITTER 2. COLLECTOR 3. COLLECTOR 4. EMITTER 5. EMITTER 6. BASE 7. BASE 8. EMITTER</p> | <p>STYLE 2: PIN 1. COLLECTOR, DIE, #1 2. COLLECTOR, #1 3. COLLECTOR, #2 4. COLLECTOR, #2 5. BASE, #2 6. EMITTER, #2 7. BASE, #1 8. EMITTER, #1</p> | <p>STYLE 3: PIN 1. DRAIN, DIE #1 2. DRAIN, #1 3. DRAIN, #2 4. DRAIN, #2 5. GATE, #2 6. SOURCE, #2 7. GATE, #1 8. SOURCE, #1</p> | <p>STYLE 4: PIN 1. ANODE 2. ANODE 3. ANODE 4. ANODE 5. ANODE 6. ANODE 7. ANODE 8. COMMON CATHODE</p> |
| <p>STYLE 5: PIN 1. DRAIN 2. DRAIN 3. DRAIN 4. DRAIN 5. GATE 6. GATE 7. SOURCE 8. SOURCE</p> | <p>STYLE 6: PIN 1. SOURCE 2. DRAIN 3. DRAIN 4. SOURCE 5. SOURCE 6. GATE 7. GATE 8. SOURCE</p> | <p>STYLE 7: PIN 1. INPUT 2. EXTERNAL BYPASS 3. THIRD STAGE SOURCE 4. GROUND 5. DRAIN 6. GATE 3 7. SECOND STAGE Vd 8. FIRST STAGE Vd</p> | <p>STYLE 8: PIN 1. COLLECTOR, DIE #1 2. BASE, #1 3. BASE, #2 4. COLLECTOR, #2 5. COLLECTOR, #2 6. EMITTER, #2 7. EMITTER, #1 8. COLLECTOR, #1</p> |
| <p>STYLE 9: PIN 1. EMITTER, COMMON 2. COLLECTOR, DIE #1 3. COLLECTOR, DIE #2 4. EMITTER, COMMON 5. EMITTER, COMMON 6. BASE, DIE #2 7. BASE, DIE #1 8. EMITTER, COMMON</p> | <p>STYLE 10: PIN 1. GROUND 2. BIAS 1 3. OUTPUT 4. GROUND 5. GROUND 6. BIAS 2 7. INPUT 8. GROUND</p> | <p>STYLE 11: PIN 1. SOURCE 1 2. GATE 1 3. SOURCE 2 4. GATE 2 5. DRAIN 2 6. DRAIN 2 7. DRAIN 1 8. DRAIN 1</p> | <p>STYLE 12: PIN 1. SOURCE 2. SOURCE 3. SOURCE 4. GATE 5. DRAIN 6. DRAIN 7. DRAIN 8. DRAIN</p> |
| <p>STYLE 13: PIN 1. N.C. 2. SOURCE 3. SOURCE 4. GATE 5. DRAIN 6. DRAIN 7. DRAIN 8. DRAIN</p> | <p>STYLE 14: PIN 1. N-SOURCE 2. N-GATE 3. P-SOURCE 4. P-GATE 5. P-DRAIN 6. P-DRAIN 7. N-DRAIN 8. N-DRAIN</p> | <p>STYLE 15: PIN 1. ANODE 1 2. ANODE 1 3. ANODE 1 4. ANODE 1 5. CATHODE, COMMON 6. CATHODE, COMMON 7. CATHODE, COMMON 8. CATHODE, COMMON</p> | <p>STYLE 16: PIN 1. EMITTER, DIE #1 2. BASE, DIE #1 3. EMITTER, DIE #2 4. BASE, DIE #2 5. COLLECTOR, DIE #2 6. COLLECTOR, DIE #2 7. COLLECTOR, DIE #1 8. COLLECTOR, DIE #1</p> |
| <p>STYLE 17: PIN 1. VCC 2. V2OUT 3. V1OUT 4. TXE 5. RXE 6. VEE 7. GND 8. ACC</p> | <p>STYLE 18: PIN 1. ANODE 2. ANODE 3. SOURCE 4. GATE 5. DRAIN 6. DRAIN 7. CATHODE 8. CATHODE</p> | <p>STYLE 19: PIN 1. SOURCE 1 2. GATE 1 3. SOURCE 2 4. GATE 2 5. DRAIN 2 6. MIRROR 2 7. DRAIN 1 8. MIRROR 1</p> | <p>STYLE 20: PIN 1. SOURCE (N) 2. GATE (N) 3. SOURCE (P) 4. GATE (P) 5. DRAIN 6. DRAIN 7. DRAIN 8. DRAIN</p> |
| <p>STYLE 21: PIN 1. CATHODE 1 2. CATHODE 2 3. CATHODE 3 4. CATHODE 4 5. CATHODE 5 6. COMMON ANODE 7. COMMON ANODE 8. CATHODE 6</p> | <p>STYLE 22: PIN 1. I/O LINE 1 2. COMMON CATHODE/VCC 3. COMMON CATHODE/VCC 4. I/O LINE 3 5. COMMON ANODE/GND 6. I/O LINE 4 7. I/O LINE 5 8. COMMON ANODE/GND</p> | <p>STYLE 23: PIN 1. LINE 1 IN 2. COMMON ANODE/GND 3. COMMON ANODE/GND 4. LINE 2 IN 5. LINE 2 OUT 6. COMMON ANODE/GND 7. COMMON ANODE/GND 8. LINE 1 OUT</p> | <p>STYLE 24: PIN 1. BASE 2. EMITTER 3. COLLECTOR/ANODE 4. COLLECTOR/ANODE 5. CATHODE 6. CATHODE 7. COLLECTOR/ANODE 8. COLLECTOR/ANODE</p> |
| <p>STYLE 25: PIN 1. VIN 2. N/C 3. REXT 4. GND 5. IOUT 6. IOUT 7. IOUT 8. IOUT</p> | <p>STYLE 26: PIN 1. GND 2. dv/dt 3. ENABLE 4. ILIMIT 5. SOURCE 6. SOURCE 7. SOURCE 8. VCC</p> | <p>STYLE 27: PIN 1. ILIMIT 2. OVLO 3. UVLO 4. INPUT+ 5. SOURCE 6. SOURCE 7. SOURCE 8. DRAIN</p> | <p>STYLE 28: PIN 1. SW_TO_GND 2. DASIC_OFF 3. DASIC_SW_DET 4. GND 5. V_MON 6. VBULK 7. VBULK 8. VIN</p> |
| <p>STYLE 29: PIN 1. BASE, DIE #1 2. EMITTER, #1 3. BASE, #2 4. EMITTER, #2 5. COLLECTOR, #2 6. COLLECTOR, #2 7. COLLECTOR, #1 8. COLLECTOR, #1</p> | <p>STYLE 30: PIN 1. DRAIN 1 2. DRAIN 1 3. GATE 2 4. SOURCE 2 5. SOURCE 1/DRAIN 2 6. SOURCE 1/DRAIN 2 7. SOURCE 1/DRAIN 2 8. GATE 1</p> | | |

| | | |
|-------------------------|--------------------|---|
| DOCUMENT NUMBER: | 98ASB42564B | Electronic versions are uncontrolled except when accessed directly from the Document Repository. Printed versions are uncontrolled except when stamped "CONTROLLED COPY" in red. |
| DESCRIPTION: | SOIC-8 NB | PAGE 2 OF 2 |

onsemi and **ONSEMI** are trademarks of Semiconductor Components Industries, LLC dba **onsemi** or its subsidiaries in the United States and/or other countries. **onsemi** reserves the right to make changes without further notice to any products herein. **onsemi** makes no warranty, representation or guarantee regarding the suitability of its products for any particular purpose, nor does **onsemi** assume any liability arising out of the application or use of any product or circuit, and specifically disclaims any and all liability, including without limitation special, consequential or incidental damages. **onsemi** does not convey any license under its patent rights nor the rights of others.

MECHANICAL CASE OUTLINE

PACKAGE DIMENSIONS

ON Semiconductor®



SCALE 2:1

Micro8 CASE 846A-02 ISSUE K

DATE 16 JUL 2020

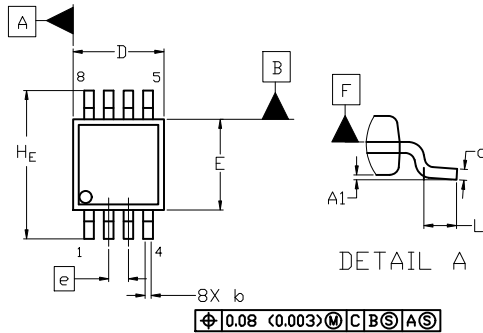

TOP VIEW

NOTE 3

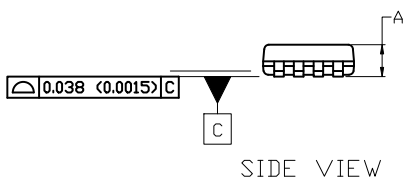

SIDE VIEW

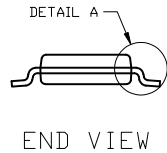

END VIEW

NOTES:

1. DIMENSIONING AND TOLERANCING PER ASME Y14.5M, 2009.
2. CONTROLLING DIMENSION: MILLIMETERS
3. DIMENSION *b* DOES NOT INCLUDE DAMBAR PROTRUSION. ALLOWABLE PROTRUSION SHALL BE 0.10 mm IN EXCESS OF MAXIMUM MATERIAL CONDITION.
4. DIMENSIONS *D* AND *E* DO NOT INCLUDE MOLD FLASH, PROTRUSION OR GATE BURRS. MOLD FLASH, PROTRUSIONS, OR GATE BURRS SHALL NOT EXCEED 0.15 mm PER SIDE. DIMENSION *E* DOES NOT INCLUDE INTERLEAD FLASH OR PROTRUSION. INTERLEAD FLASH OR PROTRUSION SHALL NOT EXCEED 0.25 mm PER SIDE. DIMENSIONS *D* AND *E* ARE DETERMINED AT DATUM *F*.
5. DATUMS *A* AND *B* ARE TO BE DETERMINED AT DATUM *F*.
6. *A1* IS DEFINED AS THE VERTICAL DISTANCE FROM THE SEATING PLANE TO THE LOWEST POINT ON THE PACKAGE BODY.

$\phi 0.08$ (0.003) M C B S A S

| DIM | MILLIMETERS | | |
|----------------------|-------------|------|------|
| | MIN. | NOM. | MAX. |
| A | --- | --- | 1.10 |
| A1 | 0.05 | 0.08 | 0.15 |
| <i>b</i> | 0.25 | 0.33 | 0.40 |
| <i>c</i> | 0.13 | 0.18 | 0.23 |
| <i>D</i> | 2.90 | 3.00 | 3.10 |
| <i>E</i> | 2.90 | 3.00 | 3.10 |
| <i>e</i> | 0.65 BSC | | |
| <i>H_E</i> | 4.75 | 4.90 | 5.05 |
| <i>L</i> | 0.40 | 0.55 | 0.70 |

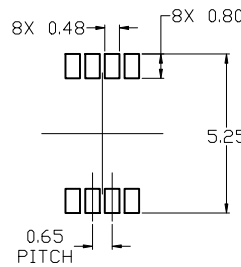

RECOMMENDED MOUNTING FOOTPRINT

For additional information on our Pb-Free strategy and soldering details, please download the ON Semiconductor Soldering and Mounting Techniques Reference Manual, SOLDERM/D.

GENERIC MARKING DIAGRAM*

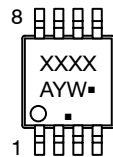

- XXXX = Specific Device Code
- A = Assembly Location
- Y = Year
- W = Work Week
- = Pb-Free Package

(Note: Microdot may be in either location)

*This information is generic. Please refer to device data sheet for actual part marking. Pb-Free indicator, "G" or microdot "▪", may or may not be present. Some products may not follow the Generic Marking.

STYLE 1:

1. SOURCE
2. SOURCE
3. SOURCE
4. GATE
5. DRAIN
6. DRAIN
7. DRAIN
8. DRAIN

STYLE 2:

1. SOURCE 1
2. GATE 1
3. SOURCE 2
4. GATE 2
5. DRAIN 2
6. DRAIN 2
7. DRAIN 1
8. DRAIN 1

STYLE 3:

1. N-SOURCE
2. N-GATE
3. P-SOURCE
4. P-GATE
5. P-DRAIN
6. P-DRAIN
7. N-DRAIN
8. N-DRAIN

| | | |
|-------------------------|--------------------|--|
| DOCUMENT NUMBER: | 98ASB14087C | Electronic versions are uncontrolled except when accessed directly from the Document Repository. Printed versions are uncontrolled except when stamped "CONTROLLED COPY" in red. |
| DESCRIPTION: | MICRO8 | PAGE 1 OF 1 |

ON Semiconductor and are trademarks of Semiconductor Components Industries, LLC dba ON Semiconductor or its subsidiaries in the United States and/or other countries. ON Semiconductor reserves the right to make changes without further notice to any products herein. ON Semiconductor makes no warranty, representation or guarantee regarding the suitability of its products for any particular purpose, nor does ON Semiconductor assume any liability arising out of the application or use of any product or circuit, and specifically disclaims any and all liability, including without limitation special, consequential or incidental damages. ON Semiconductor does not convey any license under its patent rights nor the rights of others.

onsemi, **Onsemi**, and other names, marks, and brands are registered and/or common law trademarks of Semiconductor Components Industries, LLC dba "**onsemi**" or its affiliates and/or subsidiaries in the United States and/or other countries. **onsemi** owns the rights to a number of patents, trademarks, copyrights, trade secrets, and other intellectual property. A listing of **onsemi**'s product/patent coverage may be accessed at www.onsemi.com/site/pdf/Patent-Marking.pdf. **onsemi** reserves the right to make changes at any time to any products or information herein, without notice. The information herein is provided "as-is" and **onsemi** makes no warranty, representation or guarantee regarding the accuracy of the information, product features, availability, functionality, or suitability of its products for any particular purpose, nor does **onsemi** assume any liability arising out of the application or use of any product or circuit, and specifically disclaims any and all liability, including without limitation special, consequential or incidental damages. Buyer is responsible for its products and applications using **onsemi** products, including compliance with all laws, regulations and safety requirements or standards, regardless of any support or applications information provided by **onsemi**. "Typical" parameters which may be provided in **onsemi** data sheets and/or specifications can and do vary in different applications and actual performance may vary over time. All operating parameters, including "Typicals" must be validated for each customer application by customer's technical experts. **onsemi** does not convey any license under any of its intellectual property rights nor the rights of others. **onsemi** products are not designed, intended, or authorized for use as a critical component in life support systems or any FDA Class 3 medical devices or medical devices with a same or similar classification in a foreign jurisdiction or any devices intended for implantation in the human body. Should Buyer purchase or use **onsemi** products for any such unintended or unauthorized application, Buyer shall indemnify and hold **onsemi** and its officers, employees, subsidiaries, affiliates, and distributors harmless against all claims, costs, damages, and expenses, and reasonable attorney fees arising out of, directly or indirectly, any claim of personal injury or death associated with such unintended or unauthorized use, even if such claim alleges that **onsemi** was negligent regarding the design or manufacture of the part. **onsemi** is an Equal Opportunity/Affirmative Action Employer. This literature is subject to all applicable copyright laws and is not for resale in any manner.

ADDITIONAL INFORMATION

TECHNICAL PUBLICATIONS:

Technical Library: www.onsemi.com/design/resources/technical-documentation
onsemi Website: www.onsemi.com

ONLINE SUPPORT: www.onsemi.com/support

For additional information, please contact your local Sales Representative at www.onsemi.com/support/sales