

THIS DRAWING IS UNPUBLISHED. RELEASED FOR PUBLICATION, 19  
 © COPYRIGHT 19 BY AMP INCORPORATED. ALL INTERNATIONAL RIGHTS RESERVED.

LOC	DIST	P	F	ZONE	LTR	DESCRIPTION	DATE	APPD
AF	50				B	REVISE PER ECR-13-013738	15FEB14	GRZ/JL

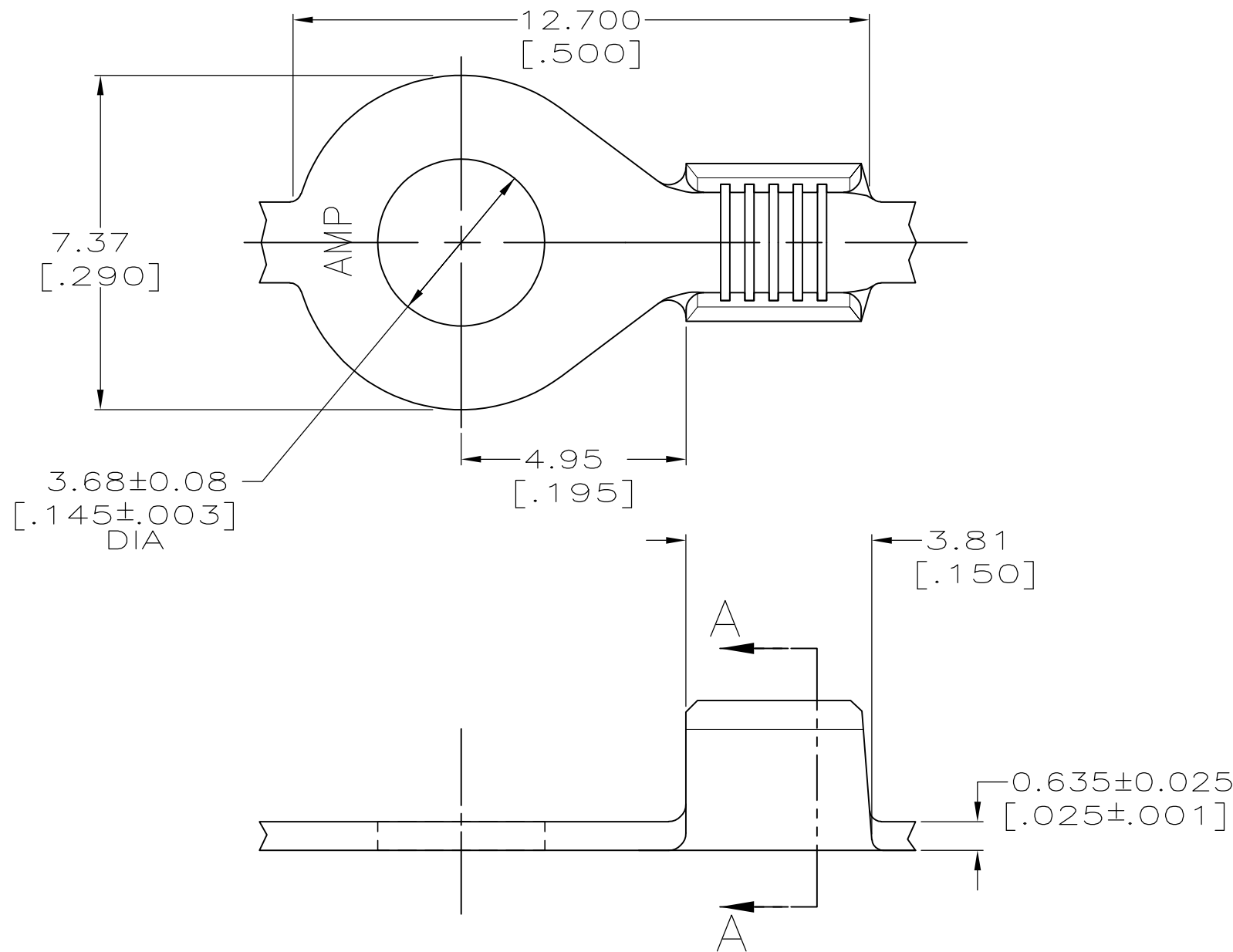

1 CONTINUOUS STRIP ON REEL.

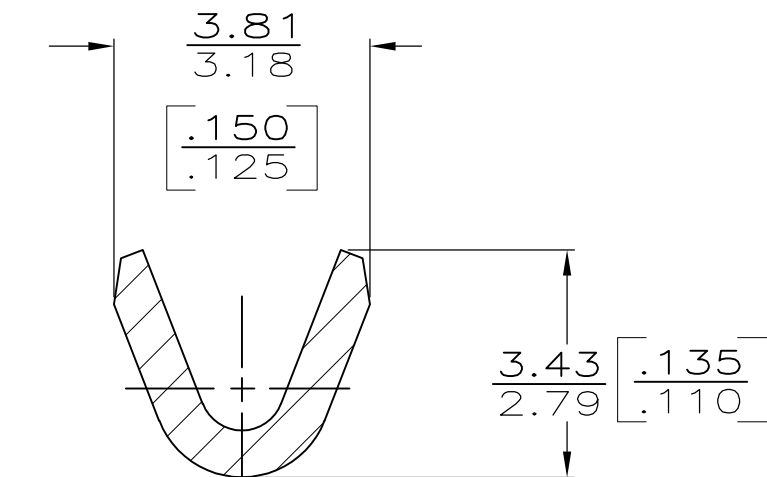

SECTION A-A  
SCALE 10:1

0.64-1.02mm DIA [22-18] AWG	63649-1
MAGNET WIRE RANGE	PART NO

F	2.79 [.110]	1.47 [.058]	0.8mm <sup>2</sup> [18]
		1.40 [.055]	0.6mm <sup>2</sup> [20]
		1.35 [.053]	0.3mm <sup>2</sup> [22]
TYPE	WIDTH	±0.051 [±.002] HEIGHT	WIRE
WIRE BARREL CRIMP			

DO NOT SCALE PRINT.  
UNLESS SPECIFIED  
DIMENSIONS IN mm [INCHES]  
TOLERANCES ON:  
2 PLC DEC ± 0.25 [.010]  
3 PLC DEC ± -  
ANGLES ± -  
MATERIAL  
BRASS  
FINISH  
0.002032 [.000080]  
MIN TIN PL  
PER MIL-T-10727

DR	5/6/92 P FORTNEY
CHK	5/6/92 MS FEHER
APPD	5/6/92 G YETTER
APPD	5/6/92 R WEAVILL
PRODUCT SPEC	-
APPLICATION SPEC	-
WEIGHT	-

<b>AMP</b> AMP Incorporated Harrisburg, PA 17105-3608		
NAME RING,AMPLIVAR		
SIZE B	CAGE CODE 00779	DRAWING NO C-63649
SCALE 8:1	SHEET 1 OF 1	

THIS DRAWING IS A CONTROLLED DOCUMENT FOR AMP INCORPORATED. IT IS SUBJECT TO CHANGE AND THE CONTROLLING ENGINEERING ORGANIZATION SHOULD BE CONTACTED FOR THE LATEST REVISION.