

LSM6DSL click

PID: MIKROE-2731

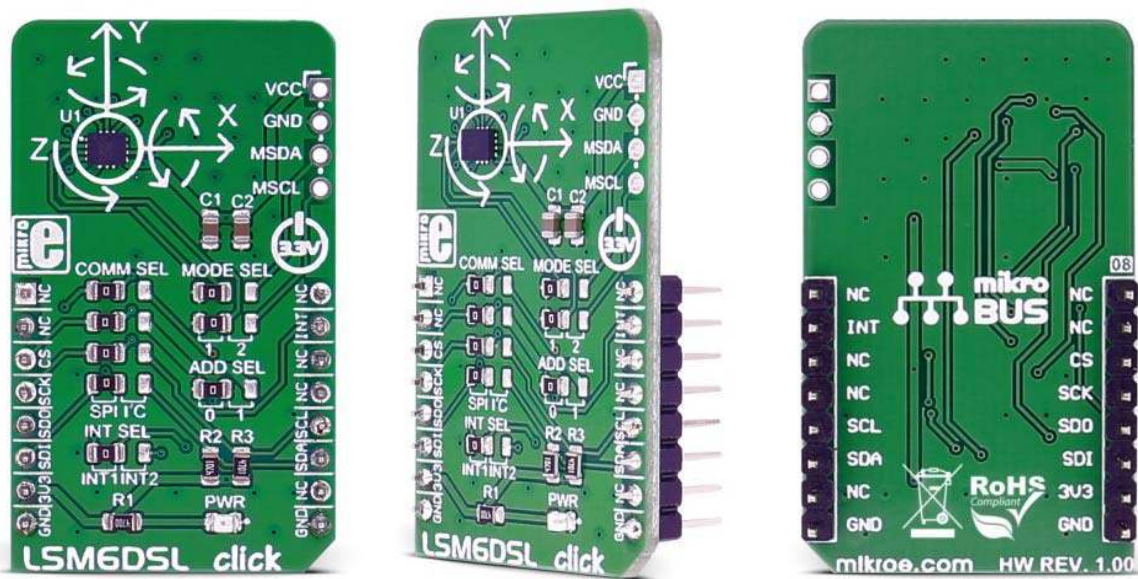

LSM6DSL click measures linear and angular velocity with six degrees of freedom. It carries the LSM6DSL high-performance 3-axis digital accelerometer and 3-axis digital gyroscope. The click is designed to run on a 3.3V power supply. LSM6DSL click communicates with the target microcontroller over SPI or I2C interface, with additional functionality provided by the INT pin on the mikroBUS™ line.

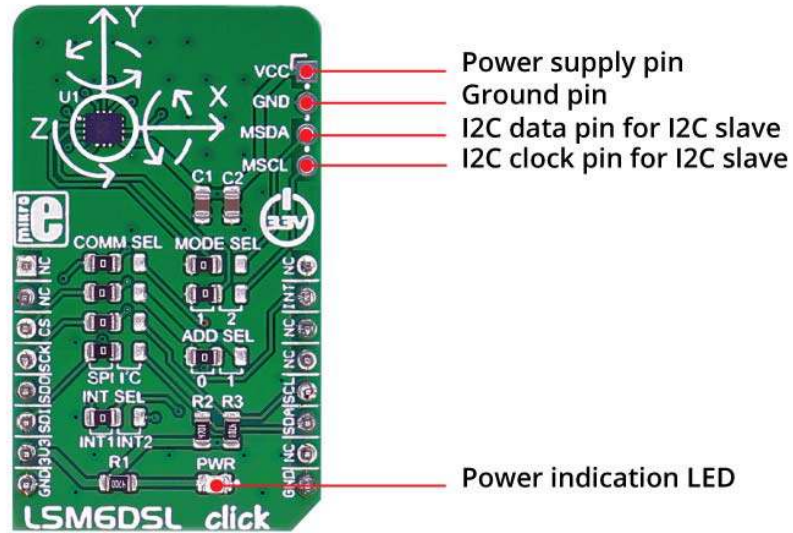

Mode 1: I2C slave interface or SPI serial interface is available.

Mode 2: I2C slave interface, or SPI serial interface and I2C interface master for external sensor connections, are available.

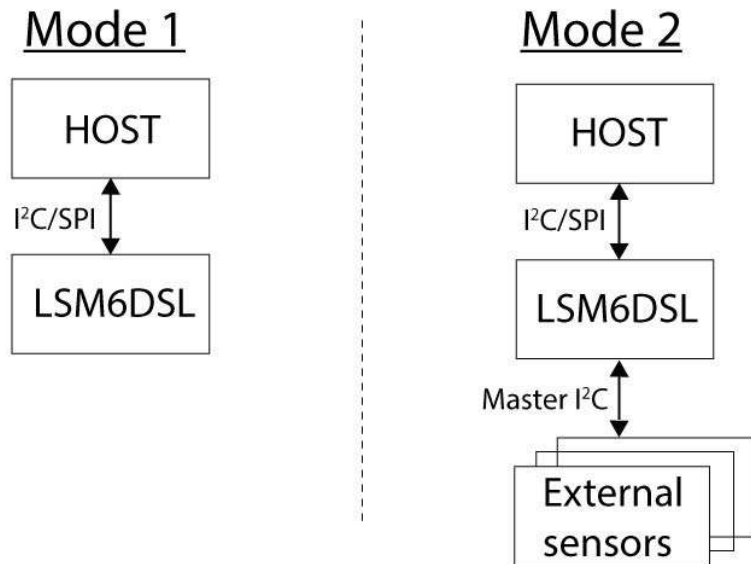

LSM6DSL inertial module features

The LSM6DSL is a system-in-package featuring a 3D digital accelerometer and a 3D digital gyroscope performing at **0.65 mA** in high-performance mode and enabling always-on low-power features for an optimal motion experience.

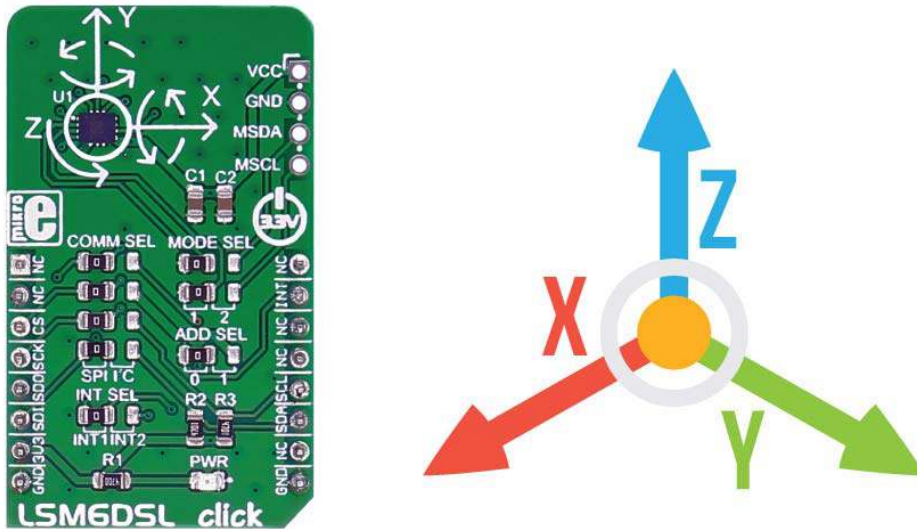

The event-detection interrupts enable efficient and reliable motion tracking and contextual awareness, implementing hardware recognition of free-fall events, 6D orientation, click and double-click sensing, activity or inactivity, and wakeup events

The LSM6DSL has a full-scale acceleration range of $\pm 2/\pm 4/\pm 8/\pm 16$ g and an angular rate range of $\pm 125/\pm 245/\pm 500/\pm 1000/\pm 2000$ dps (degrees per second).

Specifications

Type	Motion
Applications	Motion tracking and gesture detection, indoor navigation, vibration monitoring and compensation, etc.
On-board modules	LSM6DSL
Key Features	Power consumption: 0.4 mA in combo normal and 0.65 mA in combo high-performance mode; hard, soft ironing for external magnetic sensor corrections
Interface	I2C,SPI

Input Voltage	3.3V
Click board size	M (42.9 x 25.4 mm)

Pinout diagram

This table shows how the pinout on **LSM6DSL click** corresponds to the pinout on the mikroBUS™ socket (the latter shown in the two middle columns).

Notes	Pin	 mikro™ BUS				Pin	Notes
	NC	1	AN	PWM	16	NC	
	NC	2	RST	INT	15	INT	Programmable interrupt
Chip select	CS	3	CS	TX	14	NC	
SPI clock	SCK	4	SCK	RX	13	NC	
Master input slave output	MISO	5	MISO	SCL	12	SCL	I2C clock
Master output slave input	MOSI	6	MOSI	SDA	11	SDA	I2C data
Power supply	+3.3V	7	3.3V	5V	10	NC	
Ground	GND	8	GND	GND	9	GND	Ground

Jumpers and settings

Designator	Name	Default Position	Default Option	Description
JP1	COMM SEL	Left	SPI	Communication Interface Selection SPI/I2C, left position SPI, right position I2C
JP2	COMM SEL	Left	SPI	Communication Interface Selection SPI/I2C, left position SPI, right position I2C
JP3	COMM	Left	SPI	Communication Interface Selection SPI/I2C, left

	SEL			position SPI, right position I2C
JP4	INT SEL	Left	INT1	Interrupt selection INT1/INT2, left position INT1, right position INT2
JP5	COMM SEL	Left	SPI	Communication Interface Selection SPI/I2C, left position SPI, right position I2C
JP6	MODE SEL	Left	1	Mode Selection 1/2, left position 1, right position 2
JP7	MODE SEL	Left	1	Mode Selection 1/2, left position 1, right position 2
JP8	ADD SEL	Left	0	I2C slave address selection 0/1, left position 0, right position 1

Programming

Code examples for LSM6DSL click, written for MikroElektronika hardware and compilers are available on Libstock.

Code snippet

The following code snippet initializes the module, the driver, and peripherals, and then outputs the measured data to UART every two seconds.

```

01 void main()
02 {
03     char txt [100];
04     float x,y,z;
05
06     systemInit();
07     LSM6DSL_initDriver(SPI3_Write, SPI3_Read);
08     UART1_Write_Text ("rnInitialized");
09
10     /*
11      * Starts measurements for acceleration and rotation at specified
12      * rate (104 HZ) and selected full-scale (+-2G, +-245DPS).
13      */
14     LSM6DSL_configureRead (CONFIG_ACCELERATION, ODR_104_HZ |
FULLSCALE_A_2);
15     LSM6DSL_configureRead (CONFIG_ROTATION, ODR_104_HZ | FULLSCALE_R_245);

```

```

16  while( 1 )
17  {
18      UART1_Write_Text ("rnAcceleration values in mili-Gs:");
19      LSM6DSL_readAccelerationXYZ (&x, &y, &z, FULLSCALE_A_2);
20      sprintf (txt, "rnX: %.2f, t Y: %.2f, t Z: %.2f", x,y,z);
21      Uart1_Write_Text (txt);
22
23      UART1_Write_Text ("rnRotation values in degrees per second:");
24      LSM6DSL_readRotationXYZ (&x, &y, &z, FULLSCALE_R_245);
25      //Values are read in mili-degrees per second, so they need to be
divided by 1000
26      sprintf (txt,
27          "rnPitch: %.2f, t Roll: %.2f, t Yaw: %.2f",
x/1000,y/1000,z/1000);
28      Uart1_Write_Text (txt);
29
30      delay_ms (2000);
31  }
32 }

```