

THIS DRAWING IS UNPUBLISHED.

RELEASED FOR PUBLICATION

--

© COPYRIGHT - TE Connectivity Ltd.

ALL RIGHTS RESERVED.

REVISIONS

P	LTR	DESCRIPTION	DATE	DWN	APVD
P		CUTTING BURR DETAILS ADDED	19NOV2018	RK	PS

- MATERIAL:  
HOUSING: POLYAMIDE 6, UL94V-2.  
COLOR: NATURAL (OFF WHITE)  
TUBULAR CONTACT: BRASS TIN, PLATED.  
SCREWS: M3, STEEL, ZINC PLATED W/ NON-HEXAVALENT CHROMATE (CHROME III).

- CURRENT RATING: 30A  
OPERATING VOLTAGE: 250V  
WIRE RANGE: 12-26 AWG

- CONTINUOUS OPERATING TEMP.: 100°C MAX.

4 CUTTING PROJECTION CAN BE ON BOTH SIDES DEPENDING ON CUTTING LOCATION

- CUTTING BURR MAX. 1mm ALLOWED.

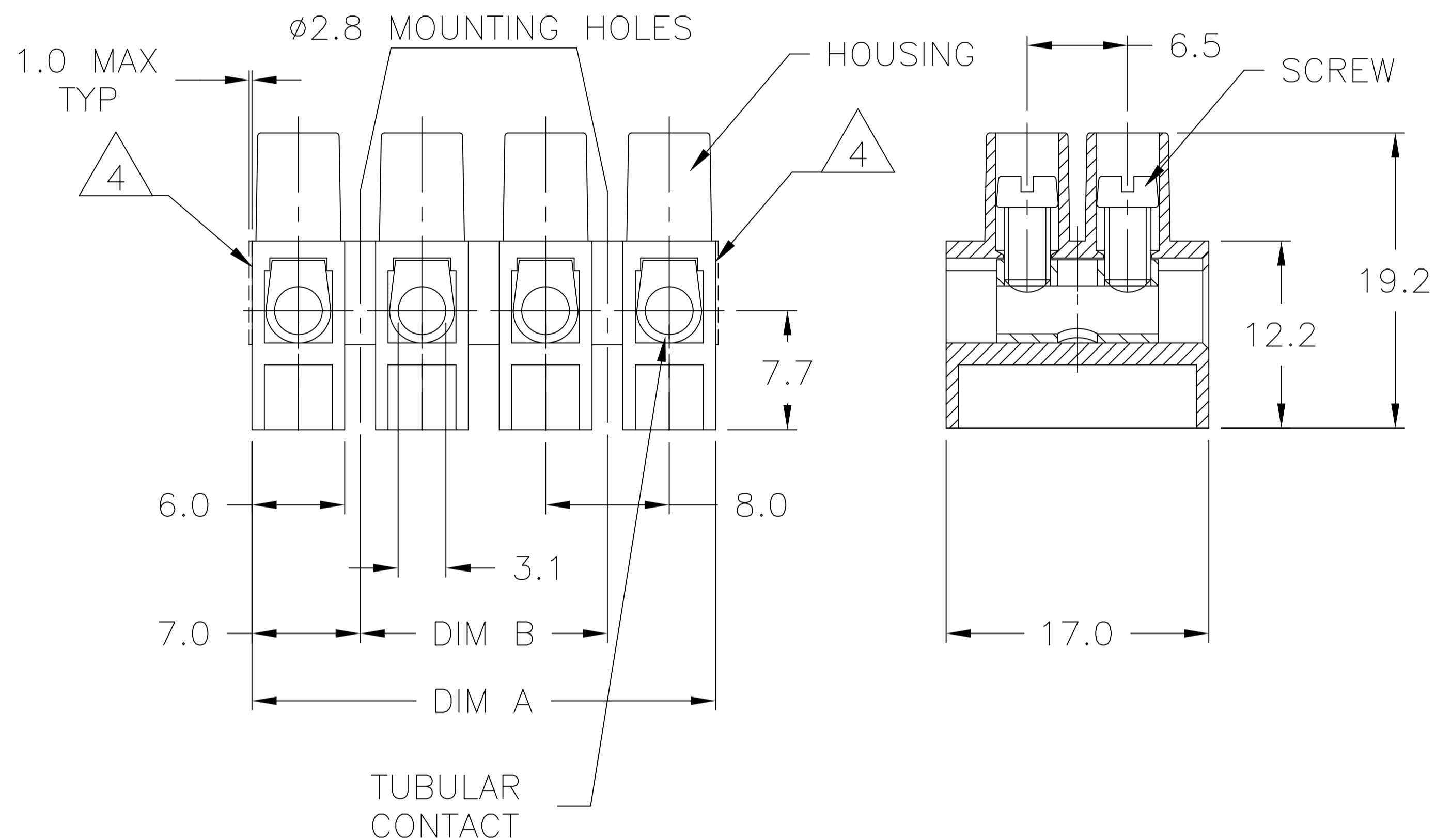

1776321-4 AS SHOWN

80.0	94.0	12	TSB230K12	1-1776321-2
72.0	86.0	11	TSB230K11	1-1776321-1
64.0	78.0	10	TSB230K10	1-1776321-0
56.0	70.0	9	TSB230K09	1776321-9
48.0	62.0	8	TSB230K08	1776321-8
40.0	54.0	7	TSB230K07	1776321-7
32.0	46.0	6	TSB230K06	1776321-6
24.0	38.0	5	TSB230K05	1776321-5
16.0	30.0	4	TSB230K04	1776321-4
8.0	22.0	3	TSB230K03	1776321-3
-	14.0	2	TSB230K02	1776321-2
-	6.0	1	TSB230K01	1776321-1
DIM B	DIM A	NO. OF POS.	CATALOG NUMBER	TE PART NUMBER

THIS DRAWING IS A CONTROLLED DOCUMENT.		DWN S SCHLEGEL 3/21/05	TE Connectivity Ltd.		
DIMENSIONS: mm		CHK C RICHARD 3/21/05			
TOLERANCES UNLESS OTHERWISE SPECIFIED:		APVD C RICHARD 3/21/05	NAME 8mm PITCH, TERMINAL BLOCK - HIGH CURRENT		
0 PLC ± - 1 PLC ± 0.3 2 PLC ± 0.25 3 PLC ± - 4 PLC ± - ANGLES ± 2°		PRODUCT SPEC	RESTRICTED TO		
MATERIAL SEE NOTES		FINISH SEE NOTES	APPLICATION SPEC	SIZE A3	CAGE CODE 00779
		WEIGHT -	DRAWING NO C=1776321	REV P	
CUSTOMER DRAWING			SCALE NTS	SHEET 1 of 1	