

THIS IS ISSUED IN STRICT CONFIDENCE THAT IT IS NOT USED AS A BASIS FOR MANUFACTURE OR SALE AND THAT IT IS NOT COPIED, REPRINTED OR DISCLOSED TO A THIRD PARTY EITHER WHOLLY OR IN PART WITHOUT THE PRIOR WRITTEN CONSENT OF CAL TEST ELECTRONICS, INC.

REVISIONS			
REV.	DESCRIPTIONS	DATE	APPROVED
—	CLASS A RELEASED	7/12/99	

- 4mm UNINSULATED SOCKET (JACK) w/Ø .080 (Ø 2.0) SOLDER HOLE.
- SPECIFICATIONS:
SOCKET BODY: BRASS, NICKEL PLATED.
- RATING:
CURRENT: 36A MAX.
TEMPERATURE: -20° C TO +150° C.
- MOUNTING HOLE: REFERENCE DIAGRAM.
- MAXIMUM PANEL THICKNESS: .50 (12.7)

PART NUMBER
CT2220

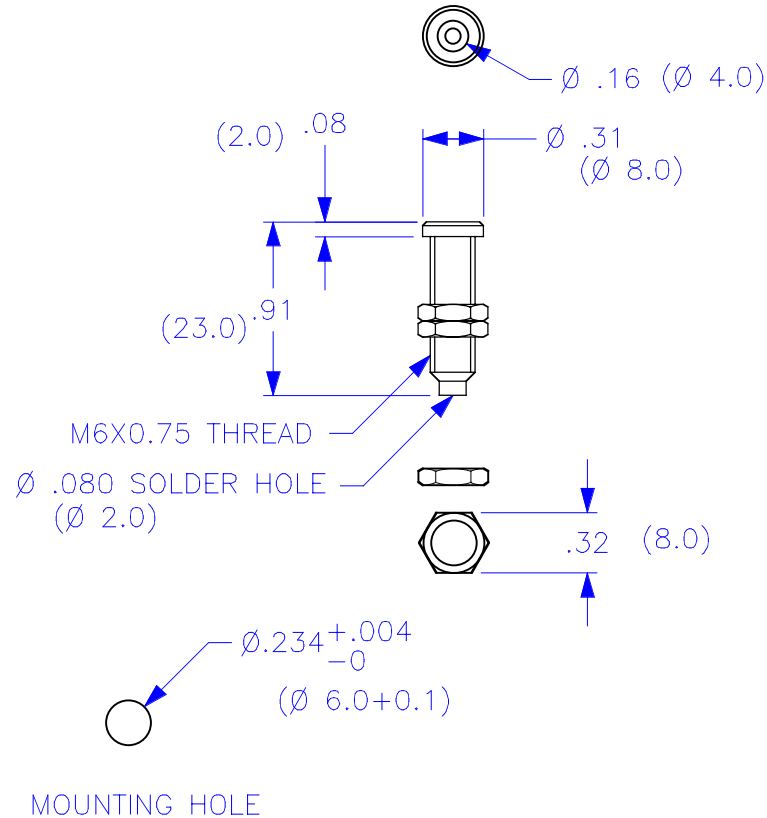

THIRD ANGLE PROJECTION		UNLESS OTHERWISE SPECIFIED DIMENSIONS ARE IN INCHES TOLERANCES ARE: FRACTIONS DECIMALS ± 1/32 .XX ± .02 .XXX ± .005 DO NOT SCALE DRAWING	CONTRACT NO.		Cal Test Electronics		22820 Savi Ranch Parkway Yorba Linda, CA 92887-4610			
			APPROVALS		DATE		TITLE			
		MATERIAL	DRAWN WDH		7/12/99		4mm SOCKET, UNINSULATED			
		FINISH	CHECKED				SIZE	CAGE CODE	DWG. NO.	REV.
NEXT ASSY			ENGR.				A		P222000	—
USED ON			DESIGN ACTIVITY				SCALE	1:1	SHEET	1 OF 1
APPLICATION										