

# MARKETING SALES DRAWING

**DIMENSIONS IN INCHES - DO NOT SCALE THIS DRAWING**  
**DIMENSIONS IN METRIC - [ ]**

Electrical Testing  
 per Tusonix standard  
 test plans and Mil-Std-202  
 Test Methods.

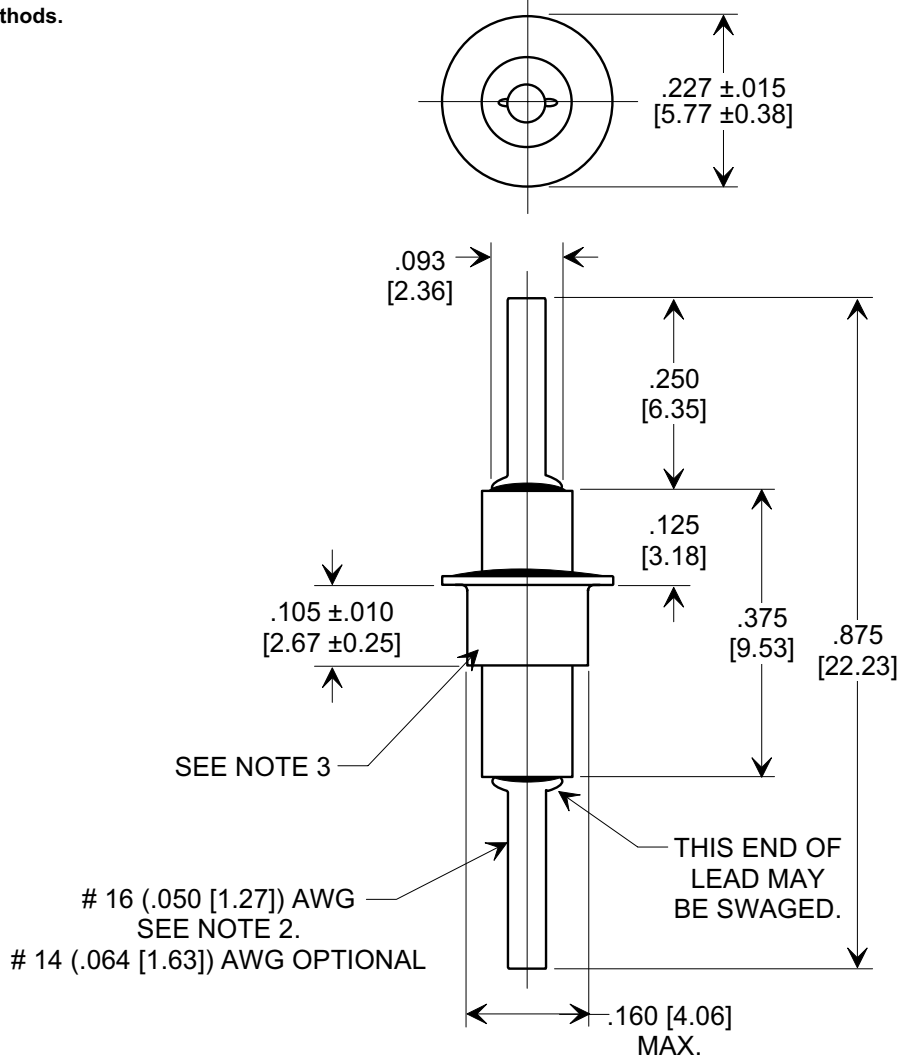
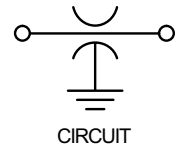
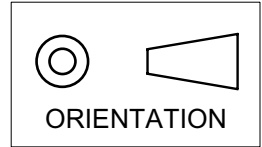

SEE NOTE 3

# 16 (.050 [1.27]) AWG  
 SEE NOTE 2.  
 # 14 (.064 [1.63]) AWG OPTIONAL

THIS END OF  
 LEAD MAY  
 BE SWAGED.

**NOTES:**

1. TUSONIX STANDARD PART NUMBER: 2404-000-X5U0-102P.  
 TUSONIX RoHS COMPLIANT PART NUMBER:  
 2404-000-X5U0-102P LF.  
 CUSTOMER MUST SPECIFY STANDARD OR RoHS PART  
 NUMBER WHEN ORDERING.
2. LEAD FINISH: STANDARD PART #: 60/40 SOLDER PLATED.  
 RoHS PART #: SILVER PLATED.
3. EYELET FINISH: STANDARD PART #: 60/40 SOLDER PLATED.  
 RoHS PART #: SILVER PLATED.
4. STANDARD VARIATIONS HAVE BOTTOM SWAGE.  
 LF VARIATIONS HAVE NO BOTTOM SWAGE.
5. PART MARKING: STANDARD PART: NO MARKING.  
 RoHS PART: GREEN DOT IDENTIFIER.

**SPECIFICATIONS**

Capacitance:	1000 pF
Cap. Tolerance:	+100, -0%
Temp. Coef.:	X5U
Operating Temp.:	-55°C TO +85°C
Voltage Rating:	500 VDC

REVISION RECORD Original Release C.O. 20000113-2-01 ADDED NOTES: S.M. 08-24-05 20050808-1-02	0
	1

--TOLERANCES-- Unless Otherwise Specified
DECIMAL ± .015 [0.38]
ANGLES ±
<b>TUSONIX</b> TUCSON, ARIZONA

Title <b>FEED - THRU CAPACITOR</b>	
Drawn S.M. 01-14-00	Scale 4 X
Approved H.R. 01-14-00	
<b>A</b>	<b>2404-000-X5U0-102P</b>