

used for: D-SUB FILTER

POS.	A ^{-0.76}	B ^{+0.25}	C ^{+0.12 -0.13}	D ^{-0.3}	Part No.
9	31.19	16.79	25.00	6.12	241A11640X
15	39.52	25.12	33.30	6.12	241A11650X
25	53.42	38.84	47.04	5.99	241A11660X
37	69.70	55.30	63.50	5.99	241A11670X

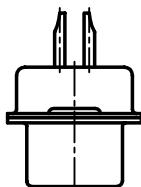
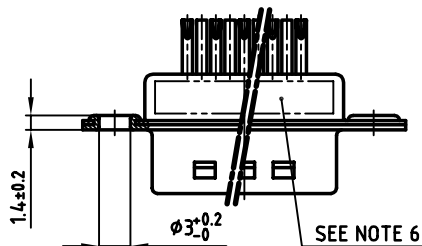
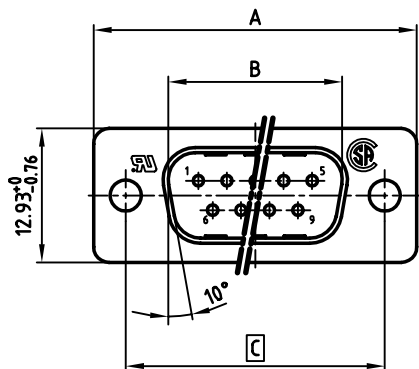
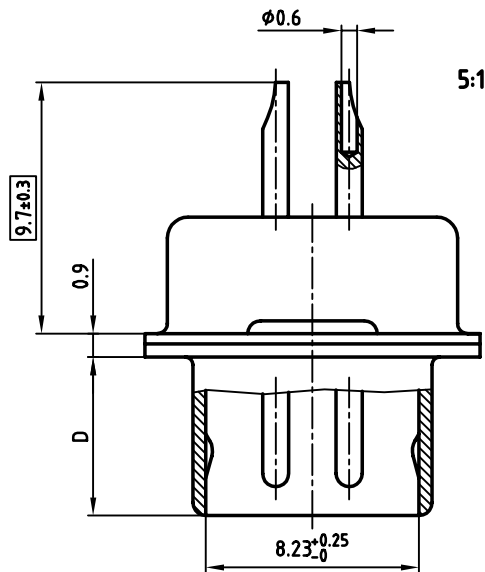

NOTES:

- METALSHELLS: STEEL; min. 320µ" TIN
- INSULATORS: PBT GF UL 94 V-0, BLACK
- CONTACTS: COPPER ALLOY
PLATING: 8µ" HARD GOLD OVER min. 50µ" NICKEL
SOLDER CUP ACCEPTS CABLE AWG 26
- CAPACITANCE: 1300pF ±20%
- DIELECTRIC WITHSTANDING VOLTAGE: 424 VDC
- CONNECTOR IS PART MARKED: PART-NO. CONEC Y/WW
- = CRITICAL DIMENSION

APPROVAL # FREIGABE # DEBLOCAGE # AUTOR/ZACON # APPROVAL	
CUSTOMER APPROVAL DATE:	
NAME:	TITLE:
COMPANY NAME:	
APPROVAL # FREIGABE # DEBLOCAGE # AUTOR/ZACON # APPROVAL	

THIS DRAWING MAY NOT BE COPIED OR REPRODUCED IN ANY WAY, AND MAY NOT BE PASSED ON TO A THIRD PARTY, WITHOUT WRITTEN PERMISSION. OWNERSHIP AND COPYRIGHT OF CONEC GmbH DO NOT ALTER CAD DRAWING BY HAND

rev.	description	date	name

tolerance	dim. in mm
2003	date
drawn	12.03.
appd.	12.03.
norm	DIN 41652
d-old	
CONEC	

scale:	2:1 (5:1)
material:	SEE NOTES
title:	D-SUB FILTER MALE 9-37pos. SOLDER CUP
dwg no:	AutoCAD 2000
part no:	24K1A365
SEE TABLE	DIN-A 3 sh:1/1