

REVISIONS			
ZONE/TR	DESCRIPTION	DATE	APPROVED
J	REVISED PER ECN# T-7641	2/11/87	M. HIGGY
X	REVISED PER ECN# T-18589	04/11/81	H. HIGGY

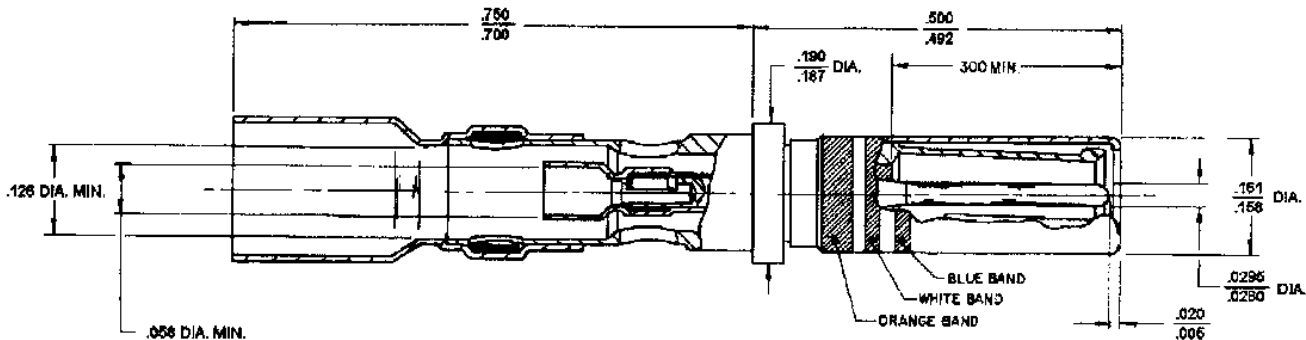

CABLE APPLICATION	
RG CABLE NO.	RAYCHEM CABLE NO.
RG-180	9528A1K1X 9528A1K2X

REQUIREMENTS:

- CONTACT MATERIAL: COPPER ALLOY PER QQ-B-626 & QQ-C-530
- INSULATOR MATERIAL: FLUOROPOLYMER
- PLATING: GOLD PER MIL-G-45204, NICKEL, PER QQ-N-290, OVER COPPER.
- MAXIMUM OPERATING TEMPERATURE: 130° C
- PERFORMANCE REQUIREMENTS PER MIL-C-39029 EXCEPT AS FOLLOWS:
 - THERMAL SHOCK: THE HIGH TEMPERATURE FOR THIS TEST SHALL BE 130° C. (MIL-STD-202, METHOD 107, TEST CONDITION A, STEP 3.)
 - TENSILE STRENGTH: FOR COAX COMBINED INNER AND OUTER: 15 LBS. (OR TENSILE STRENGTH OF COAX CABLE).
 - CONTACT RESISTANCE: 10 MILLIOHMS MAX., INNER; 8 MILLIOHMS MAX. (EXCLUDING WIRE RESISTANCE)
 - DIELECTRIC WITHSTANDING VOLTAGE: 900 VOLTS RMS MINIMUM.
 - INSULATION RESISTANCE: 5000 MEGOHMS MINIMUM.
 - ENGAGEMENT FORCE, OUTER SOCKET: 30.0 OZ. MAXIMUM.
 - SEPARATION FORCE, OUTER SOCKET: 3.0 OZ. MINIMUM.

NOTES:

- THIS CONTACT IS DESIGNED FOR USE IN MIL-C-83723, SERIES 3, TYPE B CONNECTORS.
- THIS CONTACT IS DESIGNED TO ACCOMMODATE RG 180/U OR EQUIVALENT OTHER APPLICATIONS SHOULD BE SUBMITTED TO RAYCHEM FOR EVALUATION.
- INSERTION-EXTRACTION TOOL: M83723-3-12 OR MS27534-12
- FOR ADDITIONAL REQUIREMENTS SEE MIL-C-39029/73.
- FOR TERMINATION PROCEDURE SEE RAYCHEM SPECIFICATION ES 81134.
- MATING CONTACT (FOR SIMILAR CABLES): D-602-0106

CONNECTOR SPECIFICATION CONTROL DRAWING

UNLESS OTHERWISE SPECIFIED DIMENSIONS ARE IN INCHES BRACKETED DIMENSIONS () ARE METRIC AND TOLERANCES ARE: XX . ± () XX ± () A: ± ()	DRAWN	B. DEASY	7-25-80	Tyco Electronics Corporation 300 Central Expressway Menlo Park, CA 94025 USA Raychem	TITLE
	CHECKED				CONTACT, COAXIAL, SOCKET
	APPROVED	5-6	7-25-80		
	APPROVED	4/1	7/24/80		
APPROVED					
CAD NAME	602-0107.PCX	SIZE	C	CODE IDENT	DWG. NO.
				NO. 08090	D-602-0107
					WEIGHT (5.6 MAX) SHEET 1 OF 1

If this document is printed it becomes uncontrolled.
Check for the latest revision.

DO NOT SCALE THIS DRAWING