

# NCV7703B

## Triple Half-Bridge Driver with SPI Control

The NCV7703B is a fully protected Triple Half-Bridge Driver designed specifically for automotive and industrial motion control applications. The three half-bridge drivers have independent control. This allows for high side, low side, and H-Bridge control. H-Bridge control provides forward, reverse, brake, and high impedance states. The drivers are controlled via a standard Serial Peripheral Interface (SPI). This device is fully compatible with ON Semiconductor's NCV7708 Double Hex Driver.

### Features

- Ultra Low Quiescent Current in Sleep Mode, 1  $\mu$ A for  $V_S$  and  $V_{CC}$
- Power Supply Voltage Operation down to 5 V
- 3 High-Side and 3 Low-Side Drivers Connected as Half-Bridges
- Internal Free-Wheeling Diodes
- Configurable as H-Bridge Drivers
- 0.5 A Continuous (1 A peak) Current
- $R_{DS(on)} = 0.8 \Omega$  (typ)
- 5 MHz SPI Control with Daisy Chain Capability
- Compliance with 5 V and 3.3 V Systems
- Overvoltage and Undervoltage Lockout
- Fault Reporting
- 1.4 A Overcurrent Threshold Detection with Optional Shutdown
- 3 A Current Limit with Auto Shutdown
- Overtemperature Warning and Protection Levels
- Internally Fused Leads in SOIC-14 Package for Better Thermal Performance
- ESD Protection up to 6 kV
- These are Pb-Free Devices

### Typical Applications

- Automotive
- Industrial
- DC Motor Management

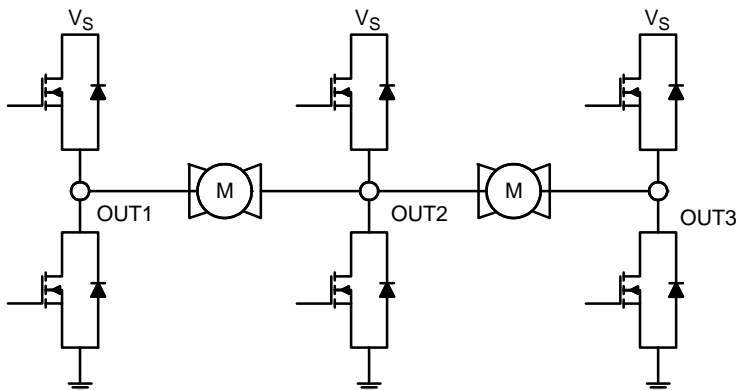

Figure 1. Cascaded Application



ON Semiconductor®

[www.onsemi.com](http://www.onsemi.com)

### MARKING DIAGRAM

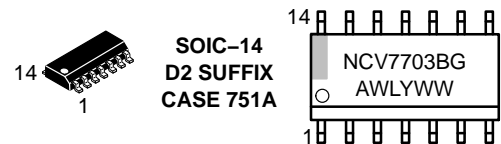

NCV7703B = Specific Device Code

A = Assembly Location  
 WL = Wafer Lot  
 Y = Year  
 WW = Work Week  
 G = Pb-Free Package

### PIN CONNECTIONS

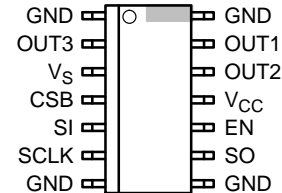

### ORDERING INFORMATION

Device	Package	Shipping†
NCV7703BD2G	SOIC-14 (Pb-Free)	55 Units / Rail
NCV7703BD2R2G	SOIC-14 (Pb-Free)	2500 / Tape & Reel

†For information on tape and reel specifications, including part orientation and tape sizes, please refer to our Tape and Reel Packaging Specifications Brochure, BRD8011/D.



# NCV7703B

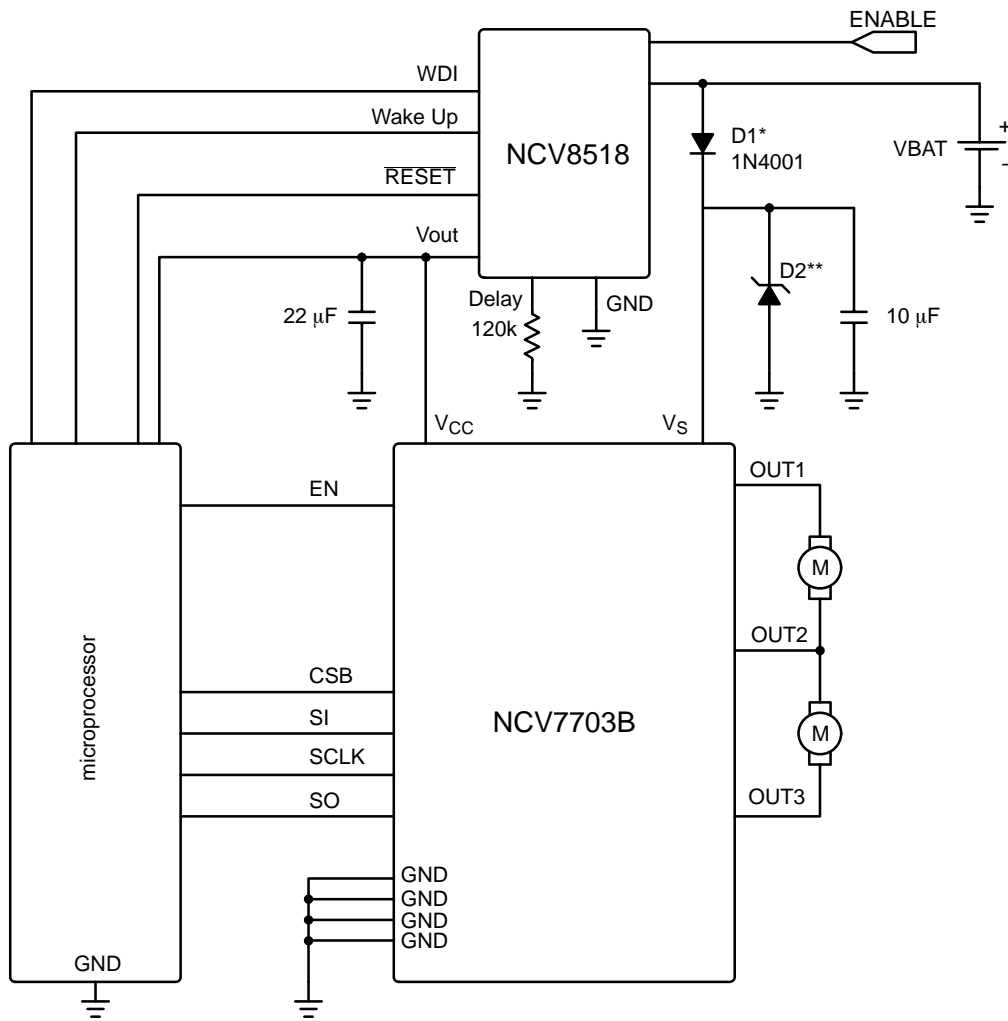

\* D1 optional. For use where reverse battery protection is required.  
 \*\* D2 optional. For use where load dump exceeds 40V.

**Figure 3. Application Circuit**

# NCV7703B

## MAXIMUM RATINGS

Rating	Value	Unit
Power Supply Voltage ( $V_S$ ) (DC) (AC), $t < 500$ ms, $I_{vs} > -2$ A	-0.3 to 40 -1	V
Output Pin OUTx (DC) (AC), $t < 500$ ms, $I_{OUTx} > -2$ A	-0.3 to 40 -1	V
Pin Voltage (Logic Input pins, SI, SCLK, CSB, SO, EN, $V_{CC}$ )	-0.3 to 7	V
Output Current (OUTx) (DC) (AC) (50 ms pulse, 1 s period)	-1.8 to 1.8 Internally Limited	A
Electrostatic Discharge, Human Body Model, $V_S$ , OUT1, OUT2, OUT3 (Note 3)	6	kV
Electrostatic Discharge, Human Body Model, all other pins (Note 3)	2	kV
Electrostatic Discharge, Machine Model, $V_S$ , OUT1, OUT2, OUT3 (Note 3)	300	V
Electrostatic Discharge, Machine Model, all other pins (Note 3)	200	V
Operating Junction Temperature	-40 to 150	°C
Storage Temperature Range	-55 to 150	°C
Moisture Sensitivity Level (MAX 260°C Processing)	MSL3	-

Stresses exceeding those listed in the Maximum Ratings table may damage the device. If any of these limits are exceeded, device functionality should not be assumed, damage may occur and reliability may be affected.

Thermal Parameters	Test Conditions (Typical Value)		Unit
	min-pad board (Note 1)	1" pad board (Note 2)	
14 Pin Fused SOIC Package			
Junction-to-Lead ( $\psi_{JL8}$ , $\Psi_{JL8}$ ) or Pins 1, 7, 8, 14	23	22	°C/W
Junction-to-Ambient ( $R_{\theta JA}$ , $\theta_{JA}$ )	122	83	°C/W

1. 1-oz copper, 67 mm<sup>2</sup> copper area, 0.062" thick FR4.
2. 1-oz copper, 645 mm<sup>2</sup> copper area, 0.062" thick FR4.
3. This device series incorporates ESD protection and is characterized by the following methods:  
 ESD HBM according to AEC-Q100-002 (EIA/JESD22-A114)  
 ESD MM according to AEC-Q100-003 (EIA/JESD22-A115)

# NCV7703B

## ELECTRICAL CHARACTERISTICS

( $-40^{\circ}\text{C} \leq T_J \leq 150^{\circ}\text{C}$ ,  $5.5\text{ V} \leq V_S \leq 40\text{ V}$ ,  $3\text{ V} \leq V_{CC} \leq 5.25\text{ V}$ ,  $\text{EN} = V_{CC}$ , unless otherwise specified)

Characteristic	Conditions	Min	Typ	Max	Unit	
<b>GENERAL</b>						
Supply Current ( $V_S$ ) Sleep Mode (Note 5)	$V_S = 13.2\text{ V}$ , $\text{OUTx} = 0\text{ V}$ $\text{EN} = \text{SI} = \text{SCLK} = 0\text{ V}$ , $\text{CSB} = V_{CC}$ $0\text{ V} < V_{CC} < 5.25\text{ V}$ ( $T_J = -40^{\circ}\text{C}$ to $85^{\circ}\text{C}$ )	–	1.0	5.0	$\mu\text{A}$	
	$V_S = 13.2\text{ V}$ , $\text{OUTx} = 0\text{ V}$ $\text{EN} = \text{SI} = \text{SCLK} = 0\text{ V}$ , $\text{CSB} = V_{CC}$ $0\text{ V} < V_{CC} < 5.25\text{ V}$ , $T_J = 25^{\circ}\text{C}$	–	–	2.0		
Supply Current ( $V_S$ ) Active Mode	$\text{EN} = V_{CC}$ , $5.5\text{ V} < V_S < 35\text{ V}$ No Load	–	2.0	4.0	$\text{mA}$	
Supply Current ( $V_{CC}$ ) Sleep Mode (Note 6)	$V_{CC} = \text{CSB}$ , $\text{EN} = \text{SI} = \text{SCLK} = 0\text{ V}$ ( $T_J = -40^{\circ}\text{C}$ to $85^{\circ}\text{C}$ )	–	0	2.5	$\mu\text{A}$	
Supply Current ( $V_{CC}$ ) Active Mode	$\text{EN} = V_{CC}$	–	1.5	3.0	$\text{mA}$	
$V_{CC}$ Power-On-Reset Threshold		2.60	2.80	3.00	$\text{V}$	
$V_S$ Undervoltage Detection	Threshold Hysteresis	$V_S$ decreasing	4.3 100	4.7 –	5.1 400	$\text{V}$ $\text{mV}$
$V_S$ Overvoltage Detection	Threshold Hysteresis	$V_S$ increasing	34.0 1.5	37.5 3.5	40.0 5.5	$\text{V}$
Thermal Warning (Note 4)	Threshold Hysteresis		120 –	145 30	170 –	$^{\circ}\text{C}$
Thermal Shutdown (Note 4)	Threshold Hysteresis		155 –	175 30	195 –	$^{\circ}\text{C}$
Ratio of Thermal Shutdown to Thermal Warning temperature (Note 4)		1.05	1.20	–	$^{\circ}\text{C}/^{\circ}\text{C}$	

## OUTPUTS

Output $R_{DS(on)}$ (Source)	$I_{out} = -500\text{ mA}$				
	$V_S = 13.2\text{ V}$ , $T_J = 25^{\circ}\text{C}$	–	0.8	0.95	$\Omega$
	$V_S = 13.2\text{ V}$	–	–	1.5	$\Omega$
	$8\text{ V} \leq V_S \leq 40\text{ V}$	–	–	1.7	$\Omega$
	$5.5\text{ V} \leq V_S \leq 8\text{ V}$ , $T_J = 25^{\circ}\text{C}$	–	1.3	–	$\Omega$
	$5.5\text{ V} \leq V_S \leq 8\text{ V}$	–	–	2.0	$\Omega$
Output $R_{DS(on)}$ (Sink)	$I_{out} = 500\text{ mA}$				
	$V_S = 13.2\text{ V}$ , $T_J = 25^{\circ}\text{C}$	–	0.8	0.95	$\Omega$
	$V_S = 13.2\text{ V}$	–	–	1.5	$\Omega$
	$8\text{ V} \leq V_S \leq 40\text{ V}$	–	–	1.7	$\Omega$
	$5.5\text{ V} \leq V_S \leq 8\text{ V}$ , $T_J = 25^{\circ}\text{C}$	–	1.3	–	$\Omega$
	$5.5\text{ V} \leq V_S \leq 8\text{ V}$	–	–	2.0	$\Omega$

Product parametric performance is indicated in the Electrical Characteristics for the listed test conditions, unless otherwise noted. Product performance may not be indicated by the Electrical Characteristics if operated under different conditions.

4. Thermal characteristics are not subject to production test

5. For temperatures above  $85^{\circ}\text{C}$ , refer to Figure 4.

6. For temperatures above  $85^{\circ}\text{C}$ , refer to Figure 5.

# NCV7703B

## ELECTRICAL CHARACTERISTICS

( $-40^{\circ}\text{C} \leq T_J \leq 150^{\circ}\text{C}$ ,  $5.5\text{ V} \leq V_S \leq 40\text{ V}$ ,  $3\text{ V} \leq V_{CC} \leq 5.25\text{ V}$ ,  $\text{EN} = V_{CC}$ , unless otherwise specified)

Characteristic	Conditions	Min	Typ	Max	Unit
<b>OUTPUTS</b>					
Source Leakage Current Sum of $I(\text{OUT}_x)$ $x = 1, 2, 3$	$\text{OUT}_x = 0\text{ V}$ , $V_S = 40\text{ V}$ , $\text{EN} = 0\text{ V}$ $\text{CSB} = V_{CC}$ $0\text{ V} < V_{CC} < 5.25\text{ V}$ Sum( $I(\text{OUT}_x)$ )  $\text{OUT}_x = 0\text{ V}$ , $V_S = 40\text{ V}$ , $\text{EN} = 0\text{ V}$ $\text{CSB} = V_{CC}$ $0\text{ V} < V_{CC} < 5.25\text{ V}$ , $T_J = 25^{\circ}\text{C}$ Sum( $I(\text{OUT}_x)$ )	-5.0	-	-	$\mu\text{A}$
Sink Leakage Current	$\text{OUT}_x = V_S = 40\text{ V}$ , $\text{EN} = 0\text{ V}$ $\text{CSB} = V_{CC}$ $0\text{ V} < V_{CC} < 5.25\text{ V}$	-	-	300	$\mu\text{A}$
	$\text{OUT}_x = V_S = 13.2\text{ V}$ , $\text{EN} = 0\text{ V}$ $\text{CSB} = V_{CC}$ $0\text{ V} < V_{CC} < 5.25\text{ V}$ , $T_J = 25^{\circ}\text{C}$	-	-	10	
Over Current Shutdown Threshold	Source Sink	-1.8 1.0	-1.4 1.4	-1.0 1.8	A
Current Limit	Source Sink	-5.0 2.0	-3.0 3.0	-2.0 5.0	A
Under Load Detection Threshold	Source Sink	-15 3.0	-7.0 7.0	-2.0 15	mA
Power Transistor Body Diode Forward Voltage	$I_f = 500\text{ mA}$	-	0.9	1.3	V

Product parametric performance is indicated in the Electrical Characteristics for the listed test conditions, unless otherwise noted. Product performance may not be indicated by the Electrical Characteristics if operated under different conditions.

4. Thermal characteristics are not subject to production test
5. For temperatures above  $85^{\circ}\text{C}$ , refer to Figure 4.
6. For temperatures above  $85^{\circ}\text{C}$ , refer to Figure 5.

# NCV7703B

## ELECTRICAL CHARACTERISTICS

( $-40^{\circ}\text{C} \leq T_J \leq 150^{\circ}\text{C}$ ,  $5.5\text{ V} \leq V_S \leq 40\text{ V}$ ,  $3\text{ V} \leq V_{CC} \leq 5.25\text{ V}$ ,  $EN = V_{CC}$ , unless otherwise specified)

Characteristic	Conditions	Min	Typ	Max	Unit
----------------	------------	-----	-----	-----	------

### LOGIC INPUTS (EN, SI, SCLK, CSB)

Input Threshold High Low		– 30	– –	70 –	$\%V_{CC}$
Input Hysteresis		100	350	600	mV
Input Pulldown Current (EN, SI, SCLK)	$EN = SI = SCLK = V_{CC}$	5.0	25	50	$\mu\text{A}$
Input Pullup Current (CSB)	$CSB = 0\text{ V}$	–50	–25	–5	$\mu\text{A}$
Input Capacitance (Note 7)		–	10	15	pF

### LOGIC OUTPUT (SO)

Output High	$I_{out} = 1\text{ mA}$	$V_{CC} - 1.0$	$V_{CC} - 0.7$	–	V
Output Low	$I_{out} = -1.6\text{ mA}$	–	0.2	0.4	V
Tri-state Leakage	$CSB = V_{CC}$ , $0\text{ V} \leq SO \leq V_{CC}$	–10	–	10	$\mu\text{A}$
Tri-state Input Capacitance (Note 7)	$CSB = V_{CC}$	–	10	15	pF

### TIMING SPECIFICATIONS

Overcurrent Shutdown Delay Time Source Sink		10 10	25 25	50 50	$\mu\text{s}$
Current Limit Fault Delay	$V_S > 8\text{ V}$	–	200	–	$\mu\text{s}$
Under Load Detection Delay Time		200	350	600	$\mu\text{s}$
High Side Turn On Time	$V_S = 13.2\text{ V}$ , $R_{load} = 25\ \Omega$	–	7.5	15	$\mu\text{s}$
High Side Turn Off Time	$V_S = 13.2\text{ V}$ , $R_{load} = 25\ \Omega$	–	3.0	6.0	$\mu\text{s}$
Low Side Turn On Time	$V_S = 13.2\text{ V}$ , $R_{load} = 25\ \Omega$	–	6.5	15	$\mu\text{s}$
Low Side Turn Off Time	$V_S = 13.2\text{ V}$ , $R_{load} = 25\ \Omega$	–	3.0	6.0	$\mu\text{s}$
High Side Rise Time	$V_S = 13.2\text{ V}$ , $R_{load} = 25\ \Omega$	–	5.0	10	$\mu\text{s}$
High Side Fall Time	$V_S = 13.2\text{ V}$ , $R_{load} = 25\ \Omega$	–	2.0	5.0	$\mu\text{s}$
Low Side Rise Time	$V_S = 13.2\text{ V}$ , $R_{load} = 25\ \Omega$	–	1.0	3.0	$\mu\text{s}$
Low Side Fall Time	$V_S = 13.2\text{ V}$ , $R_{load} = 25\ \Omega$	–	1.0	3.0	$\mu\text{s}$
NonOverlap Time	High Side Turn Off to Low Side Turn On	1.0	–	–	$\mu\text{s}$
NonOverlap Time	Low Side Turn Off to High Side Turn On	1.0	–	–	$\mu\text{s}$

Product parametric performance is indicated in the Electrical Characteristics for the listed test conditions, unless otherwise noted. Product performance may not be indicated by the Electrical Characteristics if operated under different conditions.

7. Not production tested.

# NCV7703B

## ELECTRICAL CHARACTERISTICS

( $-40^{\circ}\text{C} \leq T_J \leq 150^{\circ}\text{C}$ ,  $5.5\text{ V} \leq V_S \leq 40\text{ V}$ ,  $3\text{ V} \leq V_{CC} \leq 5.25\text{ V}$ ,  $\text{EN} = V_{CC}$ , unless otherwise specified)

### SERIAL PERIPHERAL INTERFACE

Characteristic	Conditions	Timing Chart # (See Figure 8)	Min	Typ	Max	Unit
SCLK Frequency	$V_{CC} = 5\text{ V}$	–	–	–	5	MHz
SCLK Clock Period	$V_{CC} = 5\text{ V}$	–	200	–	–	ns
	$V_{CC} = 3.3\text{ V}$	–	500	–	–	
Maximum Input Capacitance (Note 8)	SI, SCLK	–	–	–	15	pF
SCLK High Time		1	85	–	–	ns
SCLK Low Time		2	85	–	–	ns
SCLK Setup Time		3	85	–	–	ns
		4	85	–	–	
SI Setup Time		11	50	–	–	ns
SI Hold Time		12	50	–	–	ns
CSB Setup Time		5	100	–	–	ns
		6	100	–	–	
CSB High Time (Note 9)		7	200	–	–	ns
SO enable after CSB falling edge (Note 8)		8	–	–	50	ns
SO disable after CSB rising edge (Note 8)		9	–	–	50	ns
SO Rise Time	$V_{CC} = 5\text{ V}$ , $C_{load} = 40\text{ pF}$	–	–	10	25	ns
SO Fall Time	$V_{CC} = 5\text{ V}$ , $C_{load} = 40\text{ pF}$	–	–	10	25	ns
SO Valid Time (Note 8)	SCLK $\uparrow$ to SO 50%	10	–	20	50	ns

Product parametric performance is indicated in the Electrical Characteristics for the listed test conditions, unless otherwise noted. Product performance may not be indicated by the Electrical Characteristics if operated under different conditions.

8. Not tested in production.

9. Minimum high time of CSB between two successive SPI commands.



TYPICAL CHARACTERISTICS

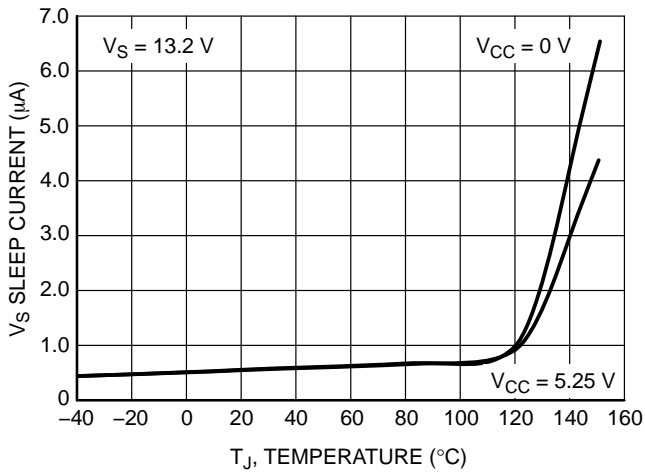

Figure 4.  $V_S$  Sleep Supply Current vs. Temperature

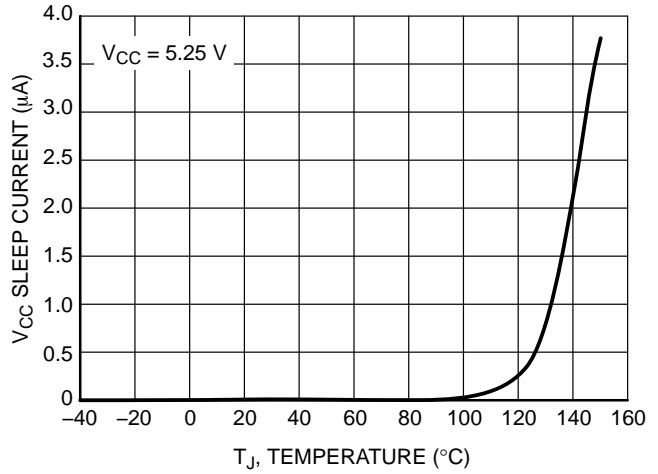

Figure 5.  $V_{CC}$  Sleep Supply Current vs. Temperature

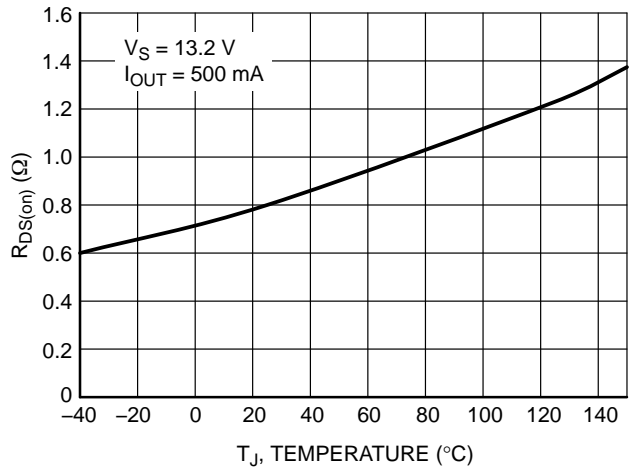

Figure 6. (Source / Sink)  $R_{DS(on)}$  vs. Temperature

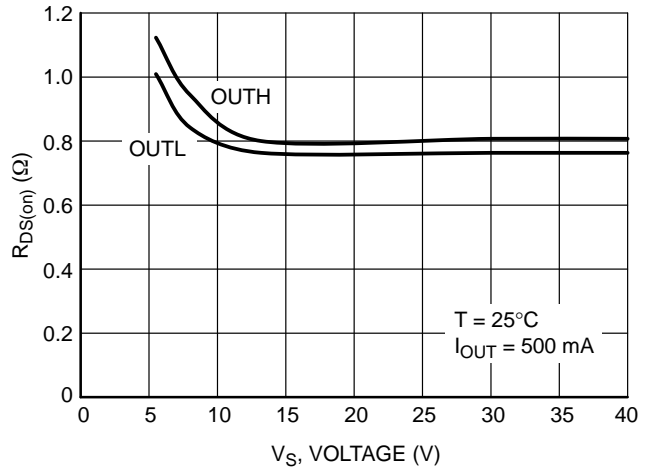

Figure 7.  $R_{DS(on)}$  vs.  $V_S$

# NCV7703B

## Detailed SPI Timing

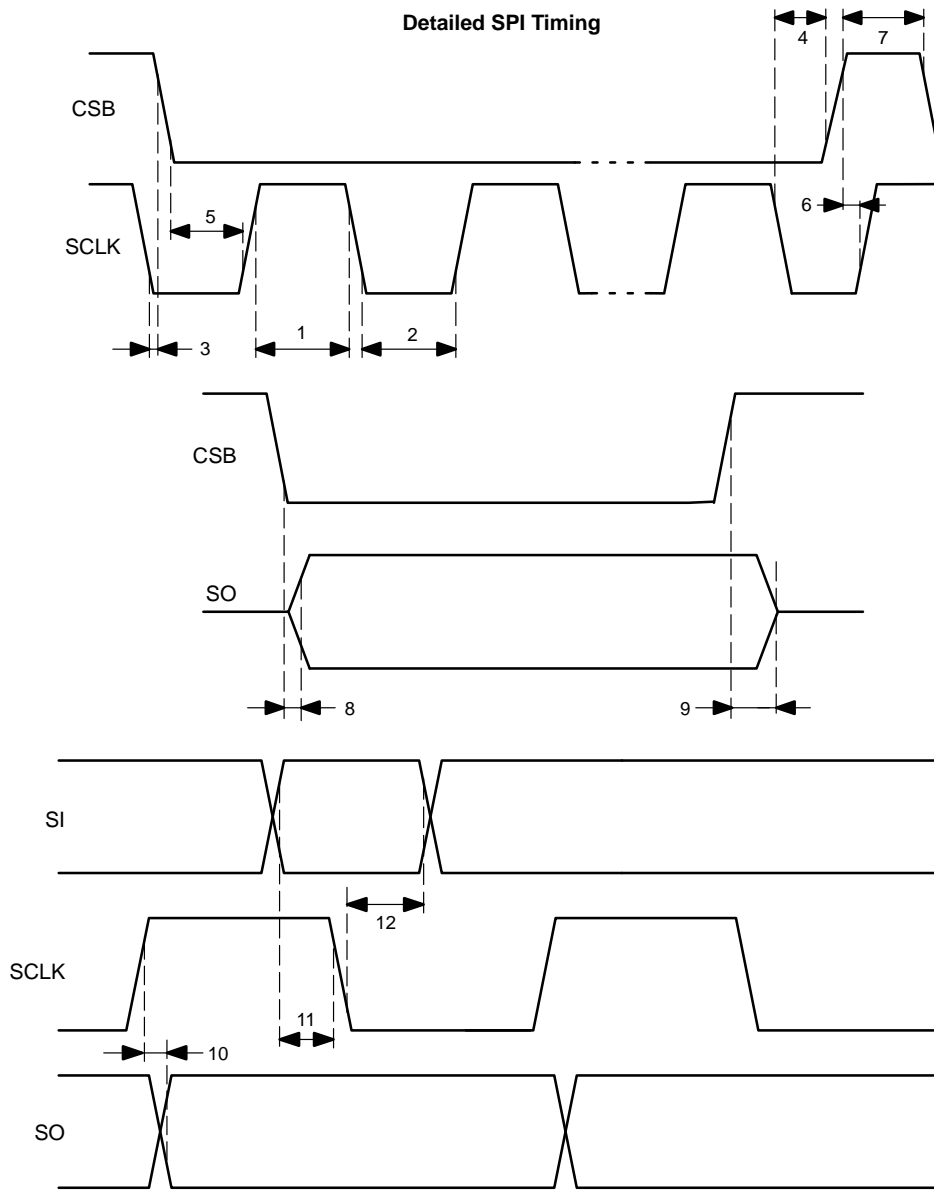

Figure 8. SPI Timing Waveforms

TYPICAL CHARACTERISTICS

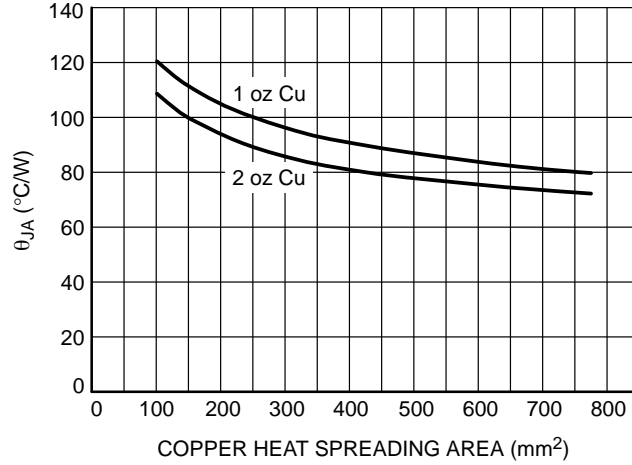

Figure 9.  $\theta_{JA}$  vs. Copper Spreader Area, 14 Lead SON (fused leads)

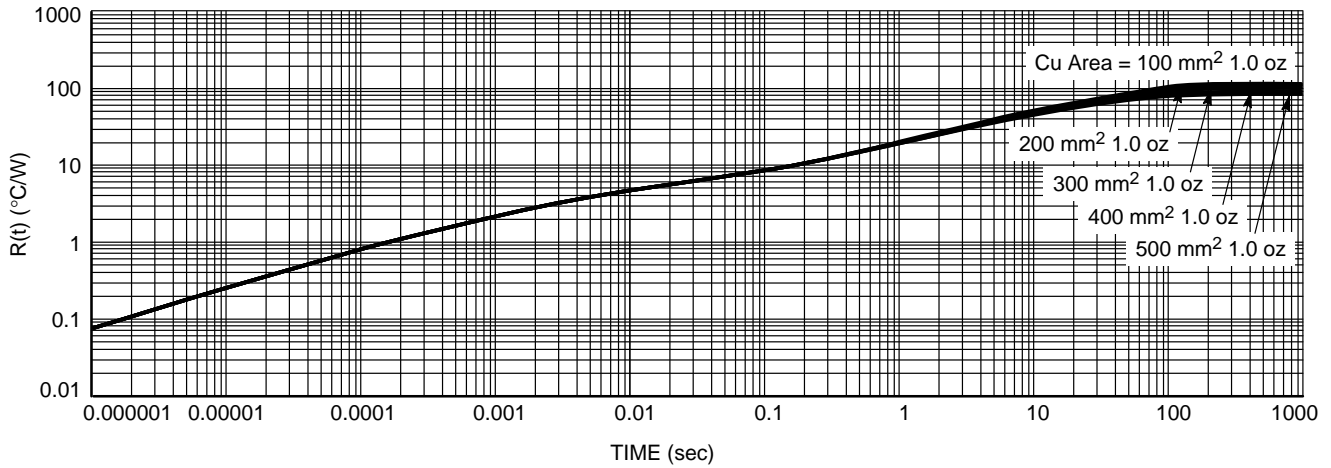

Figure 10. Transient Thermal Response to a Single Pulse 1 oz Copper (Log-Log)

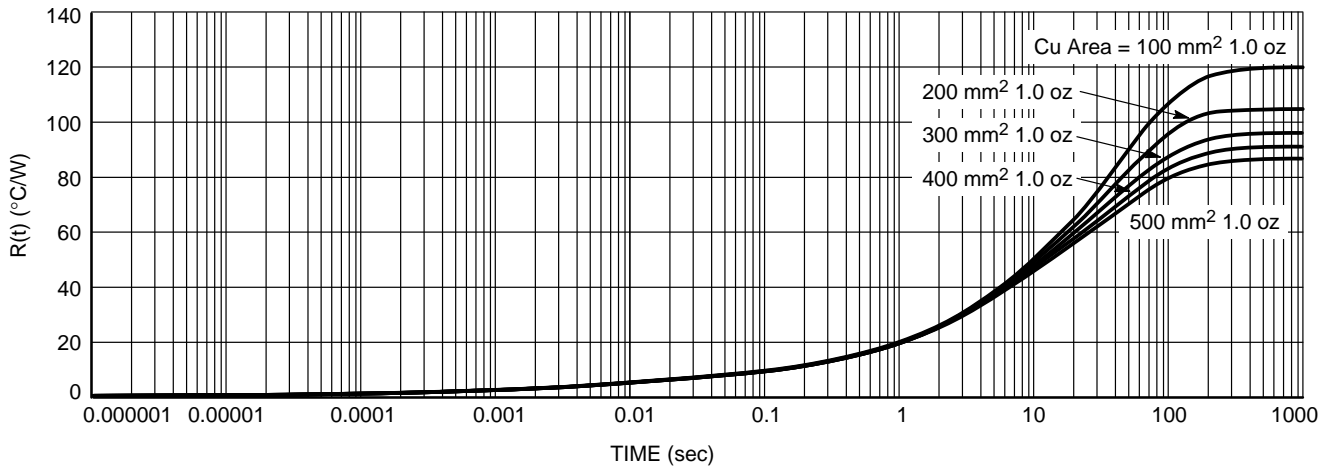

Figure 11. Transient Thermal Response to a Single Pulse 1 oz Copper (Semi-Log)

**SPI Communication**

Standard 16-bit communication has been implemented to this IC to turn drivers on/off, and to report faults. (See Figure 13). The LSB (Least Significant Bit) is clocked in first.

**Communication is Implemented as Follows:**

1. CSB goes low to allow serial data transfer.
2. A 16 bit word is clocked (SCLK) into the SI (Serial Input) pin.
3. CSB goes high to transfer the clocked in information to the data registers.

NOTE: SO is tristate when CSB is high.

**Frame Detection**

Input word integrity (SI) is evaluated by the use of a frame consistency check. The word frame length is compared to an  $\eta \times 16$  bit acceptable word length before the data is latched into the input register. This guarantees the proper word length has been imported and allows for daisy chain operation applications.

The frame length detector is enabled with the CSB falling edge and the SCLK rising edge.

SCLK must be low during the CSB rising edge. The fault register is cleared with a valid frame detection. Existing faults are re-latched after the fault filter time.

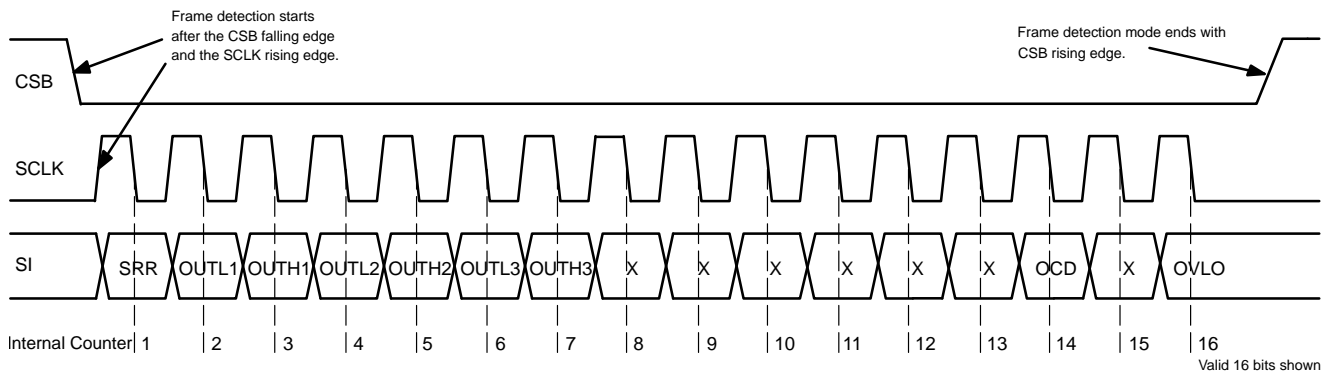

Figure 12. Frame Detection

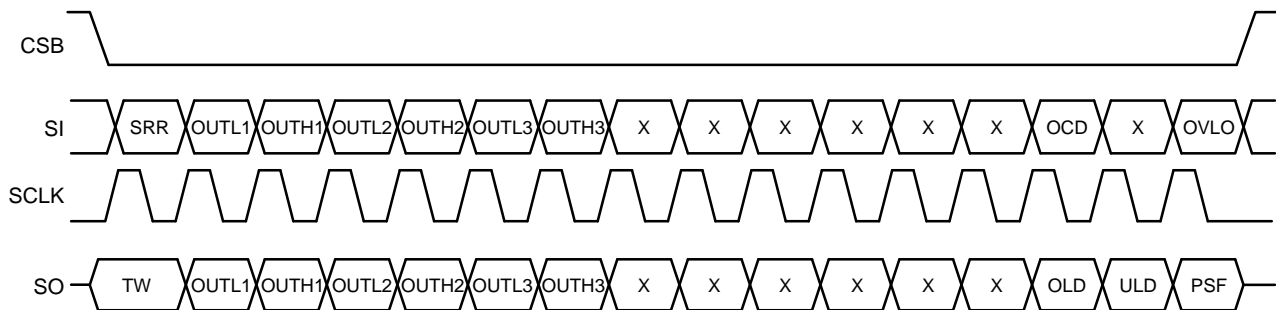

Figure 13. SPI Communication Frame Format

Table 1 defines the programming bits and diagnostic bits. Figure 13 displays the timing diagram associated with Table 1. Fault information is sequentially clocked out the SO pin of the NCV7703B as programming information is

clocked into the SI pin of the device. Daisy chain communication between SPI compatible IC's is possible by connection of the Serial Output pin (SO) to the input of the sequential IC (SI) (Reference the Daisy Chain Section).

Table 1. SPI BIT DESCRIPTION

Input Data			Output Data		
Bit Number	Bit Description	Bit Status	Bit Number	Bit Description	Bit Status
15	Over Voltage Lock Out Control (OVLO)	0 = Disable	15	Power Supply Fail Signal (PSF for OVLO or UVLO)	0 = No Fault
		1 = Enable			1 = Fault
14	Not Used		14	Under Load Detect Signal (ULD)	0 = No Fault
					1 = Fault
13	Over Current Detection Shut Down Control (OCD)	0 = Disable	13	Over Load Detect Signal (OLD)	0 = No Fault
		1 = Enable			1 = Fault
12	Not Used		12	Not Used	
11	Not Used		11	Not Used	
10	Not Used		10	Not Used	
9	Not Used		9	Not Used	
8	Not Used		8	Not Used	
7	Not Used		7	Not Used	
6	OUTH3	0 = Off	6	OUTH3	0 = Off
		1 = On			1 = On
5	OUTL3	0 = Off	5	OUTL3	0 = Off
		1 = On			1 = On
4	OUTH2	0 = Off	4	OUTH2	0 = Off
		1 = On			1 = On
3	OUTL2	0 = Off	3	OUTL2	0 = Off
		1 = On			1 = On
2	OUTH1	0 = Off	2	OUTH1	0 = Off
		1 = On			1 = On
1	OUTL1	0 = Off	1	OUTL1	0 = Off
		1 = On			1 = On
0	Status Register Reset (SRR)	0 = No Reset	0	Thermal Warning (TW)	0 = Not in TW
		1 = Reset			1 = In TW

**DETAILED OPERATING DESCRIPTION**

**General**

The NCV7703B Triple Half Bridge Driver provides drive capability for 3 Half-Bridge configurations. Each output drive is characterized for a 500 mA load and has a typical 1.4 A surge capability. Strict adherence to integrated circuit die temperature is necessary, with a maximum die temperature of 150°C. This may limit the number of drivers enabled at one time. Output drive control and fault reporting are handled via the SPI (Serial Peripheral Interface) port.

An Enable function (EN) provides a low quiescent sleep current mode when the device is not being utilized. A pull down is provided on the EN, SI and SCLK inputs to ensure they default to a low state in the event of a severed input signal. A pull-up is provided on the CSB input disabling SPI communication in the event of an open CSB input.

**Power Up/Down Control**

A feature incorporated in the IC is an under voltage lockout circuit that prevents the output drivers from turning on unintentionally.  $V_{CC}$  and  $V_S$  are monitored for undervoltage conditions supporting a smooth turn-on transition. All drivers are initialized in the off (high impedance) condition, and will remain off during a  $V_{CC}$  or  $V_S$  undervoltage condition. This allows power up sequencing of  $V_{CC}$ , and  $V_S$  up to the user. Once  $V_{CC}$  is out of UVLO, SPI communication can begin regardless of the voltage on  $V_S$ . However, drivers will remain off if  $V_S$  is in an undervoltage condition. Hysteresis in the UVLO circuits results in glitch free operation during power up/down.

**H-Bridge Driver Configuration**

The NCV7703B has the flexibility of controlling each half bridge driver independently. This allows for high side, low side and H-bridge control. H-bridge control provides forward, reverse, brake and high impedance states.

**Overvoltage Clamping – Driving Inductive Loads**

Each output is internally clamped to ground and  $V_S$  by internal free wheeling diodes. The diodes have ratings that complement the FETs they protect.

**Overcurrent Shutdown Threshold Detection (Table 2)**

The state of input bit 13 (OCD) selects driver reaction when reaching overcurrent shutdown threshold. With a “0” for input bit 13, the OLD status bit will be set to “1” when the level exceeds the overcurrent shutdown shut-down threshold and the driver will remain on. With a “1” for input bit 13, the output driver shuts off when the overcurrent shutdown threshold is exceeded and can only be turned back on via the SPI port with a SPI command that includes an SRR = 1. Note: high currents could cause a high rise in die temperature. Devices will not be allowed to turn on if the die temperature exceeds the thermal shutdown temperature.

**Current Limit Fault**

The current limit fault circuit will shut down the offending output driver when the Current Limit (Source or Sink) has

been exceeded for a duration greater than 200  $\mu$ s, regardless of the OLD input bit status. The OUTx output bit will report a “0” indicating which driver encountered the hard short. The OLD status bit will be set and will remain set until a new SRR input SPI command is executed.

**Under-Load Detection (Table 3)**

The under-load detection circuit monitors the current from each output driver. A minimum load current (this is the maximum open circuit detection threshold) is required when the drivers are turned on. If the under-load detection threshold has been detected for more than the under-load delay time, the ULD bit (output bit #14) will be set to a “1”. The under load bit is reset with SRR.

**Overvoltage Shutdown (Table 4)**

Overvoltage lockout circuitry monitors the voltage on the  $V_S$  pin. The response to an overvoltage condition is selected by SPI input bit 15. PSF output bit 15 is set when a  $V_S$  overvoltage condition exists. If input bit 15 (OVLO) is set to “1”, all outputs will turn off during this overvoltage condition. Turn On/Off status is maintained in the logic circuitry, so that when proper input voltage level is reestablished, the programmed outputs will turn back on. The PSF output bit is reset with SRR.

**Table 2. INPUT BIT 13, OVERCURRENT DETECTION SHUT DOWN CONTROL AND RESPONSE**

OLD Input Bit 13 Set	Typical Load Current Condition	Output Bit 13 OLD Status	OUTx Status
0	$I_L \leq 1.4 \text{ A}$	0	Unchanged
0	$1.4 \text{ A} < I_L \leq 3 \text{ A}$	1 (Need SRR to reset)	Unchanged
0	$I_L \geq 3 \text{ A}$ , for 200 $\mu$ s (typ)	1 (Need SRR to reset)	OUTx Latched Off (Need SRR to reset)
1	$I_L \leq 1.4 \text{ A}$	0	Unchanged
1	$I_L > 1.4 \text{ A}$ , for 25 $\mu$ s (typ)	1 (Need SRR to reset)	OUTx Latched Off (Need SRR to reset)

**Table 3. OUTPUT BIT 14, UNDER LOAD DETECTION SHUT DOWN**

OUTx ULD Set	Output Data Bit 14, Under Load Detect (ULD) Status	OUTx Status
0	0	Unchanged
1	1 (Need SRR to reset)	Unchanged

**Table 4. INPUT BIT 15, OVERVOLTAGE LOCK OUT (OVLO) SHUT DOWN**

OVLO Input Bit 15	$V_S$ OVLO Condition	Output Data Bit 15 Power Supply Fail (PSF) Status	OUTx Status
0	0	0	Unchanged
0	1	1 (Need SRR to reset)	Unchanged
1	0	0	Unchanged
1	1	1 (Need SRR to reset)	All Outputs Shut Off (Remain off until $V_S$ is out of OVLO)

**Thermal Shutdown**

Three independent thermal shutdown circuits are featured (one common sensor for each HS and LS transistor pair). Each sensor has two temperature levels; Level 1, Thermal Warning sets the “TW” status bit to a 1 and would have to be reset with a command that includes the SRR after the IC cools to a temperature below Level 1. The output will remain on in this condition.

If the IC temperature reaches Level 2, Over Temperature Shutdown, all drivers are latched off. It can be reset only after the part cools below the shutdown temperature, (including thermal hysteresis) with a turn-on command that includes the SRR set bit.

The output data bit 0, Thermal Warning, will latch and remain set, even after cooling, and is reset by sending a SPI command to reset the status register (SRR, input 0 set to “1”). Since thermal warning precedes a thermal shutdown,

software polling of this bit will allow for load control and possible prevention of thermal shutdown conditions.

Thermal warning information can be retrieved immediately without performing a complete SPI access cycle. Figure 14 below displays how this is accomplished. Bringing the CSB pin from a high to low condition immediately displays the information on the Output Data Bit 0, thermal warning, even in the absence of an SCLK signal. As the temperature of the NCV7703B changes from a condition from below the thermal warning threshold to above the thermal warning threshold, the state of the SO pin changes and this level is available immediately when the CSB goes low. A low on SO indicates there is no thermal warning, while a high indicates the IC is above the thermal warning threshold. This warning bit is reset by setting SRR to “1”.

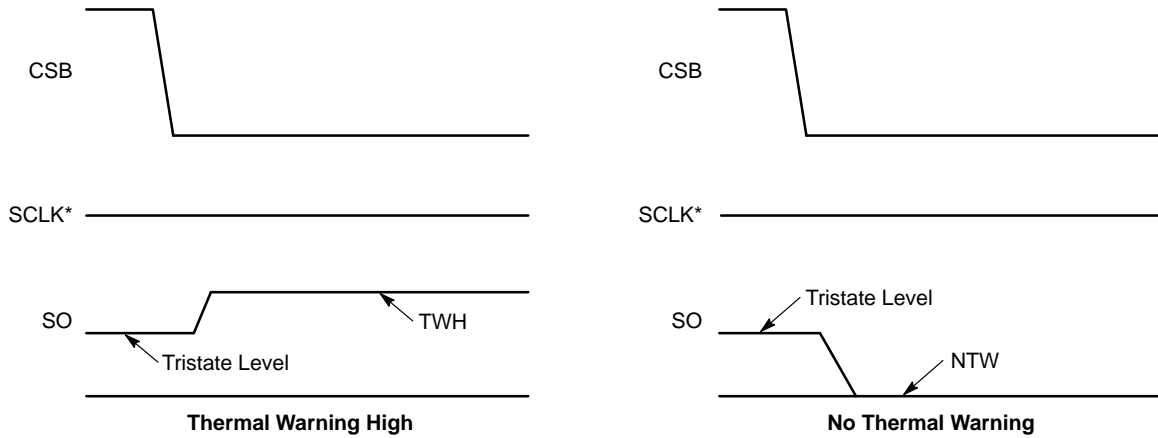

\*SCLK can be high or low in order to maintain the thermal information on SO. Toggling SCLK will cause other output bits to shift out.  
 TWH = Thermal Warning High  
 NTW = No Thermal Warning

**Figure 14. Access to Temperature Warning Information**

**Applications Drawing**

**Daisy Chain**

The NCV7703B is capable of being setup in a daisy chain configuration with other similar devices which include additional NCV7703B devices as well as the NCV7708 Double Hex Driver. Particular attention should be focused on the fact that the first 16 bits which are clocked out of the SO pin when the CSB pin transitions from a high to a low

will be the Diagnostic Output Data. These are the bits representing the status of the IC and are detailed in the SPI Bit Description Table. Additional programming bits should be clocked in which follow the Diagnostic Output bits. Word length must be  $\eta \times 16$  due to the use of frame detection.

# NCV7703B

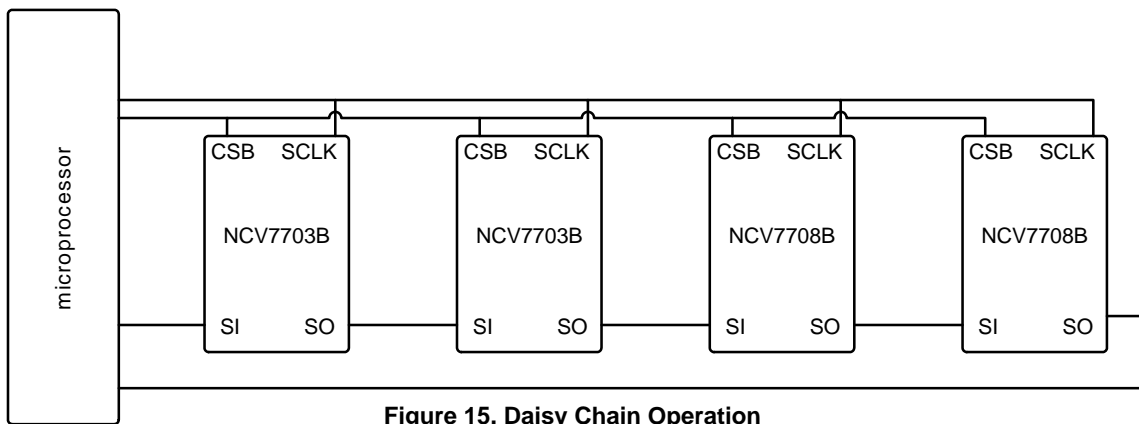

Figure 15. Daisy Chain Operation

## Parallel Control

A more efficient way to control multiple SPI compatible devices is to connect them in a parallel fashion and allow each device to be controlled in a multiplex mode. The diagram below shows a typical connection between the microprocessor or microcontroller and multiple SPI compatible devices. In a daisy chain configuration, the programming information for the last device in the serial string must first pass through all the previous devices. The parallel control setup eliminates that requirement, but at the cost of additional control pins from the microprocessor for each individual CSB pin for each controllable device. Serial data is only recognized by the device that is activated through its respective CSB pin.

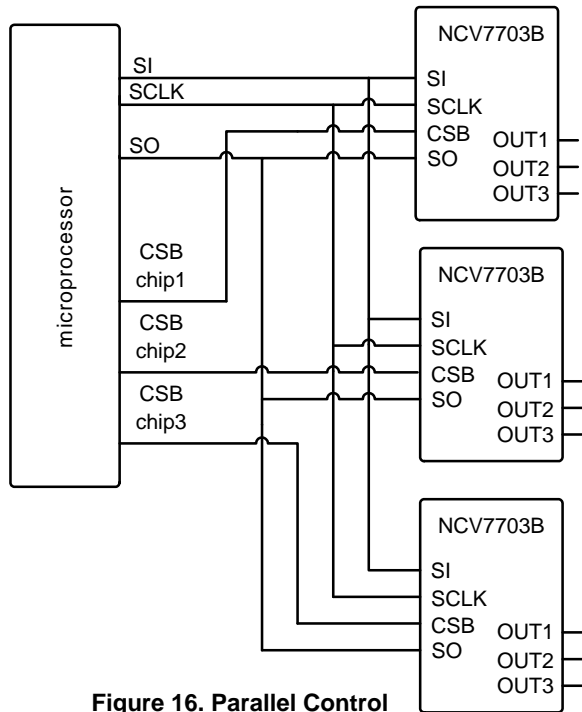

Figure 16. Parallel Control

## Additional Application Setup

In addition to the cascaded H-Bridge application shown in Figure 1, the NCV7703B can also be used as a high-side driver or low-side driver (Figure 17).

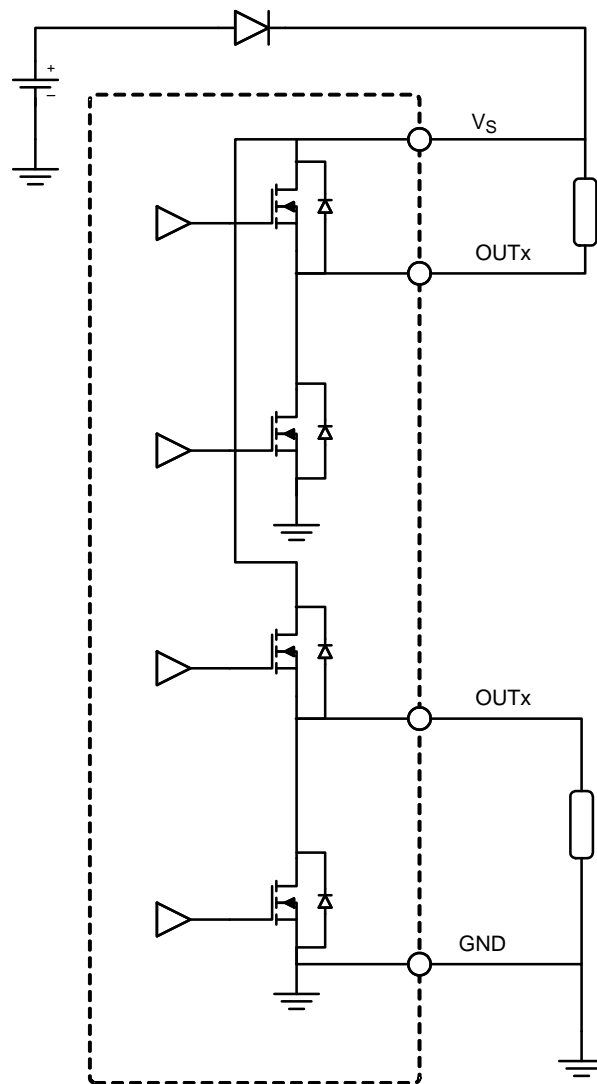
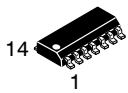

Figure 17. High-Side / Low-Side Application Drawing

Any combination of H-bridge and high or low-side drivers can be designed in. This allows for flexibility in many systems.



# MECHANICAL CASE OUTLINE PACKAGE DIMENSIONS



SCALE 1:1

SOIC-14 NB  
CASE 751A-03  
ISSUE L

DATE 03 FEB 2016

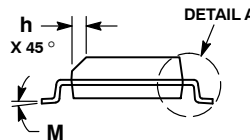
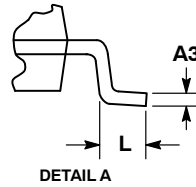
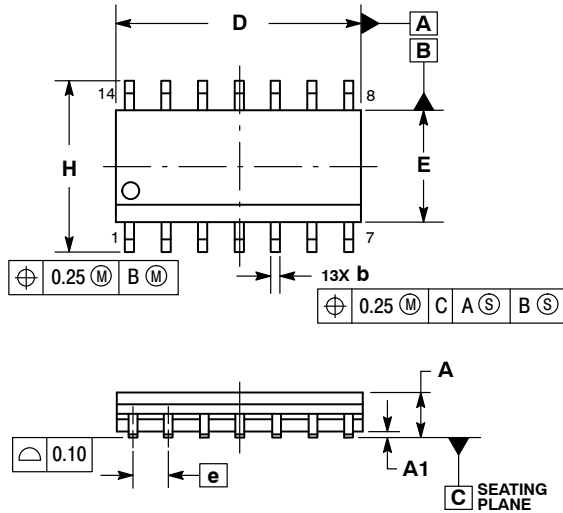

NOTES:

1. DIMENSIONING AND TOLERANCING PER ASME Y14.5M, 1994.
2. CONTROLLING DIMENSION: MILLIMETERS.
3. DIMENSION b DOES NOT INCLUDE DAMBAR PROTRUSION. ALLOWABLE PROTRUSION SHALL BE 0.13 TOTAL IN EXCESS OF AT MAXIMUM MATERIAL CONDITION.
4. DIMENSIONS D AND E DO NOT INCLUDE MOLD PROTRUSIONS.
5. MAXIMUM MOLD PROTRUSION 0.15 PER SIDE.

DIM	MILLIMETERS		INCHES	
	MIN	MAX	MIN	MAX
A	1.35	1.75	0.054	0.068
A1	0.10	0.25	0.004	0.010
A3	0.19	0.25	0.008	0.010
b	0.35	0.49	0.014	0.019
D	8.55	8.75	0.337	0.344
E	3.80	4.00	0.150	0.157
e	1.27 BSC		0.050 BSC	
H	5.80	6.20	0.228	0.244
h	0.25	0.50	0.010	0.019
L	0.40	1.25	0.016	0.049
M	0°	7°	0°	7°

SOLDERING FOOTPRINT\*

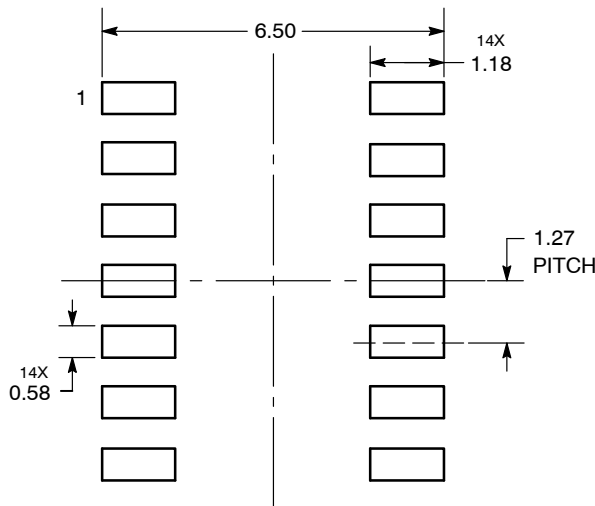

DIMENSIONS: MILLIMETERS

\*For additional information on our Pb-Free strategy and soldering details, please download the ON Semiconductor Soldering and Mounting Techniques Reference Manual, SOLDERRM/D.

GENERIC MARKING DIAGRAM\*

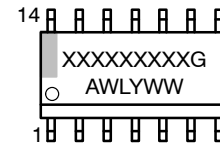

- XXXXXX = Specific Device Code
- A = Assembly Location
- WL = Wafer Lot
- Y = Year
- WW = Work Week
- G = Pb-Free Package

\*This information is generic. Please refer to device data sheet for actual part marking. Pb-Free indicator, "G" or microdot "▪", may or may not be present. Some products may not follow the Generic Marking.

STYLES ON PAGE 2

DOCUMENT NUMBER:	98ASB42565B	Electronic versions are uncontrolled except when accessed directly from the Document Repository. Printed versions are uncontrolled except when stamped "CONTROLLED COPY" in red.
DESCRIPTION:	SOIC-14 NB	PAGE 1 OF 2

onsemi and onsemi are trademarks of Semiconductor Components Industries, LLC dba onsemi or its subsidiaries in the United States and/or other countries. onsemi reserves the right to make changes without further notice to any products herein. onsemi makes no warranty, representation or guarantee regarding the suitability of its products for any particular purpose, nor does onsemi assume any liability arising out of the application or use of any product or circuit, and specifically disclaims any and all liability, including without limitation special, consequential or incidental damages. onsemi does not convey any license under its patent rights nor the rights of others.

**SOIC-14**  
**CASE 751A-03**  
**ISSUE L**

DATE 03 FEB 2016

STYLE 1:  
 PIN 1. COMMON CATHODE  
 2. ANODE/CATHODE  
 3. ANODE/CATHODE  
 4. NO CONNECTION  
 5. ANODE/CATHODE  
 6. NO CONNECTION  
 7. ANODE/CATHODE  
 8. ANODE/CATHODE  
 9. ANODE/CATHODE  
 10. NO CONNECTION  
 11. ANODE/CATHODE  
 12. ANODE/CATHODE  
 13. NO CONNECTION  
 14. COMMON ANODE

STYLE 2:  
 CANCELLED

STYLE 3:  
 PIN 1. NO CONNECTION  
 2. ANODE  
 3. ANODE  
 4. NO CONNECTION  
 5. ANODE  
 6. NO CONNECTION  
 7. ANODE  
 8. ANODE  
 9. ANODE  
 10. NO CONNECTION  
 11. ANODE  
 12. ANODE  
 13. NO CONNECTION  
 14. COMMON CATHODE

STYLE 4:  
 PIN 1. NO CONNECTION  
 2. CATHODE  
 3. CATHODE  
 4. NO CONNECTION  
 5. CATHODE  
 6. NO CONNECTION  
 7. CATHODE  
 8. CATHODE  
 9. CATHODE  
 10. NO CONNECTION  
 11. CATHODE  
 12. CATHODE  
 13. NO CONNECTION  
 14. COMMON ANODE

STYLE 5:  
 PIN 1. COMMON CATHODE  
 2. ANODE/CATHODE  
 3. ANODE/CATHODE  
 4. ANODE/CATHODE  
 5. ANODE/CATHODE  
 6. NO CONNECTION  
 7. COMMON ANODE  
 8. COMMON CATHODE  
 9. ANODE/CATHODE  
 10. ANODE/CATHODE  
 11. ANODE/CATHODE  
 12. ANODE/CATHODE  
 13. NO CONNECTION  
 14. COMMON ANODE

STYLE 6:  
 PIN 1. CATHODE  
 2. CATHODE  
 3. CATHODE  
 4. CATHODE  
 5. CATHODE  
 6. CATHODE  
 7. CATHODE  
 8. ANODE  
 9. ANODE  
 10. ANODE  
 11. ANODE  
 12. ANODE  
 13. ANODE  
 14. ANODE

STYLE 7:  
 PIN 1. ANODE/CATHODE  
 2. COMMON ANODE  
 3. COMMON CATHODE  
 4. ANODE/CATHODE  
 5. ANODE/CATHODE  
 6. ANODE/CATHODE  
 7. ANODE/CATHODE  
 8. ANODE/CATHODE  
 9. ANODE/CATHODE  
 10. ANODE/CATHODE  
 11. COMMON CATHODE  
 12. COMMON ANODE  
 13. ANODE/CATHODE  
 14. ANODE/CATHODE

STYLE 8:  
 PIN 1. COMMON CATHODE  
 2. ANODE/CATHODE  
 3. ANODE/CATHODE  
 4. NO CONNECTION  
 5. ANODE/CATHODE  
 6. ANODE/CATHODE  
 7. COMMON ANODE  
 8. COMMON ANODE  
 9. ANODE/CATHODE  
 10. ANODE/CATHODE  
 11. NO CONNECTION  
 12. ANODE/CATHODE  
 13. ANODE/CATHODE  
 14. COMMON CATHODE

<b>DOCUMENT NUMBER:</b>	<b>98ASB42565B</b>	Electronic versions are uncontrolled except when accessed directly from the Document Repository. Printed versions are uncontrolled except when stamped "CONTROLLED COPY" in red.
<b>DESCRIPTION:</b>	<b>SOIC-14 NB</b>	<b>PAGE 2 OF 2</b>

**onsemi** and **ONSEMI** are trademarks of Semiconductor Components Industries, LLC dba **onsemi** or its subsidiaries in the United States and/or other countries. **onsemi** reserves the right to make changes without further notice to any products herein. **onsemi** makes no warranty, representation or guarantee regarding the suitability of its products for any particular purpose, nor does **onsemi** assume any liability arising out of the application or use of any product or circuit, and specifically disclaims any and all liability, including without limitation special, consequential or incidental damages. **onsemi** does not convey any license under its patent rights nor the rights of others.

**onsemi**, **Onsemi**, and other names, marks, and brands are registered and/or common law trademarks of Semiconductor Components Industries, LLC dba "**onsemi**" or its affiliates and/or subsidiaries in the United States and/or other countries. **onsemi** owns the rights to a number of patents, trademarks, copyrights, trade secrets, and other intellectual property. A listing of **onsemi**'s product/patent coverage may be accessed at [www.onsemi.com/site/pdf/Patent-Marking.pdf](http://www.onsemi.com/site/pdf/Patent-Marking.pdf). **onsemi** reserves the right to make changes at any time to any products or information herein, without notice. The information herein is provided "as-is" and **onsemi** makes no warranty, representation or guarantee regarding the accuracy of the information, product features, availability, functionality, or suitability of its products for any particular purpose, nor does **onsemi** assume any liability arising out of the application or use of any product or circuit, and specifically disclaims any and all liability, including without limitation special, consequential or incidental damages. Buyer is responsible for its products and applications using **onsemi** products, including compliance with all laws, regulations and safety requirements or standards, regardless of any support or applications information provided by **onsemi**. "Typical" parameters which may be provided in **onsemi** data sheets and/or specifications can and do vary in different applications and actual performance may vary over time. All operating parameters, including "Typicals" must be validated for each customer application by customer's technical experts. **onsemi** does not convey any license under any of its intellectual property rights nor the rights of others. **onsemi** products are not designed, intended, or authorized for use as a critical component in life support systems or any FDA Class 3 medical devices or medical devices with a same or similar classification in a foreign jurisdiction or any devices intended for implantation in the human body. Should Buyer purchase or use **onsemi** products for any such unintended or unauthorized application, Buyer shall indemnify and hold **onsemi** and its officers, employees, subsidiaries, affiliates, and distributors harmless against all claims, costs, damages, and expenses, and reasonable attorney fees arising out of, directly or indirectly, any claim of personal injury or death associated with such unintended or unauthorized use, even if such claim alleges that **onsemi** was negligent regarding the design or manufacture of the part. **onsemi** is an Equal Opportunity/Affirmative Action Employer. This literature is subject to all applicable copyright laws and is not for resale in any manner.

---

## ADDITIONAL INFORMATION

### TECHNICAL PUBLICATIONS:

Technical Library: [www.onsemi.com/design/resources/technical-documentation](http://www.onsemi.com/design/resources/technical-documentation)  
onsemi Website: [www.onsemi.com](http://www.onsemi.com)

### ONLINE SUPPORT: [www.onsemi.com/support](http://www.onsemi.com/support)

For additional information, please contact your local Sales Representative at [www.onsemi.com/support/sales](http://www.onsemi.com/support/sales)