

# HD3SS3415 4-Channel High-Performance Differential Switch

## 1 Features

- Compatible with Multiple Interface Standards Operating up to 12 Gbps Including PCI Express Gen III and USB 3.0
- Wide –3-dB Differential BW of over 8 GHz
- Excellent Dynamic Characteristics (at 4 GHz)
  - Crosstalk = –35 dB
  - Off Isolation = –19 dB
  - Insertion Loss = –1.5 dB
  - Return Loss = –11 dB
- VDD Operating Range 3.3 V ±10%
- Small 3.5 mm × 9 mm, 42-Pin WQFN Package
- Common Industry Standard Pinout

## 2 Applications

- Desktop and Notebook PCs
- Server/Storage Area Networks
- PCI Express Backplanes
- Shared I/O Ports

## 3 Description

The HD3SS3415 is a high-speed passive switch capable of switching four differential channels, including applications such as two full PCI Express x1 lanes from one source to one of two target locations in a PC/server application. With its bidirectional capability the HD3SS3415 will also support applications that allow connections between one target and two source devices, such as a shared peripheral between two platforms. The HD3SS3415 has a single control line (SEL Pin) which can be used to control the signal path between Port A and either Port B or Port C.

The HD3SS3415 is offered in an industry standard 42-pin WQFN package available in a common footprint shared by several other vendors. The device is specified to operate from a single supply voltage of 3.3 V over the full temperature range of 0°C to 70°C

### Device Information<sup>(1)</sup>

PART NUMBER	PACKAGE	BODY SIZE (NOM)
HD3SS3415	WQFN (42)	9.00 mm × 3.50 mm

(1) For all available packages, see the orderable addendum at the end of the datasheet.

**HD3SS3415 Pinout**

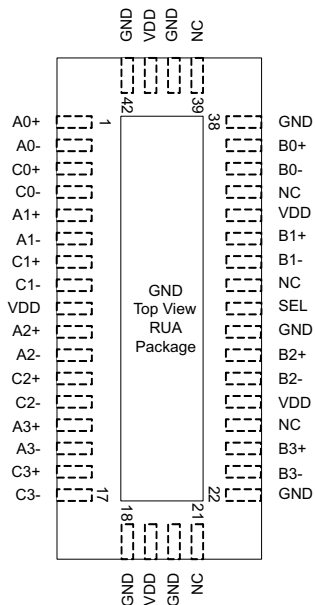

**HD3SS3415 Switch Flow Through Routing**

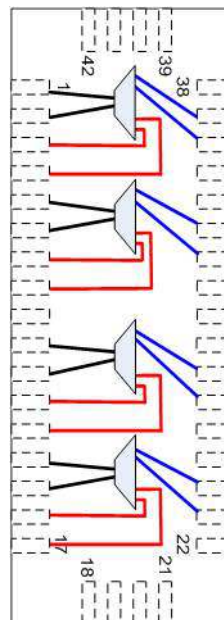

## Table of Contents

<b>1 Features</b> ..... 1 <b>2 Applications</b> ..... 1 <b>3 Description</b> ..... 1 <b>4 Revision History</b> ..... 2 <b>5 Description continued</b> ..... 3 <b>6 Pin Configuration and Functions</b> ..... 4 <b>7 Specifications</b> ..... 6 7.1 Absolute Maximum Ratings ..... 6 7.2 ESD Ratings ..... 6 7.3 Recommended Operating Conditions ..... 6 7.4 Thermal Information ..... 6 7.5 Electrical Characteristics ..... 7 7.6 Dissipation Ratings ..... 7 7.7 Typical Characteristics ..... 9 <b>8 Parameter Measurement Information</b> ..... 10 <b>9 Detailed Description</b> ..... 12 9.1 Overview ..... 12	9.2 Functional Block Diagram ..... 12 9.3 Feature Description ..... 13 9.4 Device Functional Modes ..... 13 <b>10 Application and Implementation</b> ..... 14 10.1 Application Information ..... 14 10.2 Typical Application ..... 15 <b>11 Power Supply Recommendations</b> ..... 17 <b>12 Layout</b> ..... 17 12.1 Layout Guidelines ..... 17 12.2 Layout Example ..... 17 <b>13 Device and Documentation Support</b> ..... 18 13.1 Community Resources ..... 18 13.2 Trademarks ..... 18 13.3 Electrostatic Discharge Caution ..... 18 13.4 Glossary ..... 18 <b>14 Mechanical, Packaging, and Orderable Information</b> ..... 18
--	---

## 4 Revision History

NOTE: Page numbers for previous revisions may differ from page numbers in the current version.

Changes from Revision B (August 2015) to Revision C	Page
• Changed the <i>HD3SS3415 Pinout</i> and <i>HD3SS3415 Switch Flow Through Routing</i> images ..... 1	1
• Changed temperature From: industrial temperature range of –40°C to 85°C To: industrial temperature range of 0°C to 70°C in the <i>Overview</i> section ..... 12	12

Changes from Revision A (July 2015) to Revision B	Page
• Changed the Storage temperature MIN value From: 65 To: –65 in the <i>Absolute Maximum Ratings</i> <sup>(1)(2)</sup> table ..... 6	6

Changes from Original (February 2012 ) to Revision A	Page
• Added <i>Pin Configuration and Functions</i> section, <i>ESD Ratings</i> table, <i>Feature Description</i> section, <i>Device Functional Modes</i> , <i>Application and Implementation</i> section, <i>Power Supply Recommendations</i> section, <i>Layout</i> section, <i>Device and Documentation Support</i> section, and <i>Mechanical, Packaging, and Orderable Information</i> section ..... 1	1
• Deleted the word "industrial" from <i>Description</i> section ..... 1	1
• Changed the second paragraph of the <i>Description</i> -40 to 0 and 85 to 70°C ..... 1	1
• Changed T <sub>A</sub> spec values from –40°C MIN and 85°C MAX to 0°C MIN and 70°C MAX in the <i>Recommended Operating Conditions</i> table. .... 6	6

## 5 Description continued

The HD3SS3415 is a generic 4-CH high-speed mux/demux type of switch that can be used for routing high-speed signals between two different locations on a circuit board. Although it was designed specifically to address PCI Express Gen III applications, the HD3SS3415 will also support several other high-speed data protocols with a differential amplitude of  $< 1800$  mVpp and a common mode voltage of  $< 2$  V, as with USB 3.0 and DisplayPort 1.2. The one select input (SEL) pin of the device can easily be controlled by an available GPIO pin within a system or from a microcontroller.

## 6 Pin Configuration and Functions

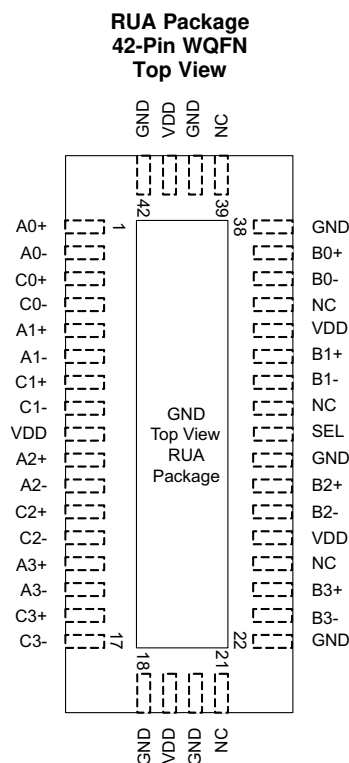

### Pin Functions

PIN		I/O	DESCRIPTION
NAME	NO.		
<b>SWITCH PORT A</b>			
A0+	1	I/O	Port A, Channel 0, High Speed Positive Signal
A0-	2		Port A, Channel 0, High Speed Negative Signal
A1+	5		Port A, Channel 1, High Speed Positive Signal
A1-	6		Port A, Channel 1, High Speed Negative Signal
A2+	10		Port A, Channel 2, High Speed Positive Signal
A2-	11		Port A, Channel 2, High Speed Negative Signal
A3+	14		Port A, Channel 3, High Speed Positive Signal
A3-	15		Port A, Channel 3, High Speed Negative Signal
<b>SWITCH PORT B</b>			
B0+	37	I/O	Port B, Channel 0, High Speed Positive Signal
B0-	36		Port B, Channel 0, High Speed Negative Signal
B1+	33		Port B, Channel 1, High Speed Positive Signal
B1-	32		Port B, Channel 1, High Speed Negative Signal
B2+	28		Port B, Channel 2, High Speed Positive Signal
B2-	27		Port B, Channel 2, High Speed Negative Signal
B3+	24		Port B, Channel 3, High Speed Positive Signal
B3-	23		Port B, Channel 3, High Speed Negative Signal

**Pin Functions (continued)**

PIN		I/O	DESCRIPTION
NAME	NO.		
<b>SWITCH PORT C</b>			
C0+	3	I/O	Port C, Channel 0, High Speed Positive Signal
C0–	4		Port C, Channel 0, High Speed Negative Signal
C1+	7		Port C, Channel 1, High Speed Positive Signal
C1–	8		Port C, Channel 1, High Speed Negative Signal
C2+	12		Port C, Channel 2, High Speed Positive Signal
C2–	13		Port C, Channel 2, High Speed Negative Signal
C3+	16		Port C, Channel 3, High Speed Positive Signal
C3–	17		Port C, Channel 3, High Speed Negative Signal
<b>CONTROL, SUPPLY, AND NO CONNECT</b>			
GND	18, 20, 22, 29, 38, 40, 42, Center Pad	Supply	Negative power supply voltage
NC	21, 25, 31, 35, 39	–	Electrically not connected
SEL	30	I	Select between port B or port C. Internally tied to GND via 100kΩ resistor
VDD	9, 19, 26, 34, 41	Supply	Positive power supply voltage

## 7 Specifications

### 7.1 Absolute Maximum Ratings<sup>(1)(2)</sup>

Over operating free-air temperature range (unless otherwise noted)

		MIN	MAX	UNIT
Supply voltage ( $V_{DD}$ )	Absolute minimum/maximum supply voltage range	-0.5	4	V
Voltage	Differential I/O	-0.5	4	V
	Control pin (SEL)	-0.5	$V_{DD}+0.5$	
Storage temperature ( $T_{stg}$ )		-65	150	°C

- (1) Stresses beyond those listed under *absolute maximum ratings* may cause permanent damage to the device. These are stress ratings only and functional operation of the device at these or any conditions beyond those indicated under *recommended operating conditions* is not implied. Exposure to absolute-maximum-rated conditions for extended periods may affect device reliability.
- (2) All voltage values, except differential voltages, are with respect to network ground terminal.

### 7.2 ESD Ratings

		VALUE	UNIT
$V_{(ESD)}$ Electrostatic discharge	Human body model (HBM), per ANSI/ESDA/JEDEC JS-001 <sup>(1)</sup>	±4000	V
	Charged-device model (CDM), per JEDEC specification JESD22-C101 <sup>(2)</sup>	±1500	

- (1) JEDEC document JEP155 states that 500-V HBM allows safe manufacturing with a standard ESD control process.
- (2) JEDEC document JEP157 states that 250-V CDM allows safe manufacturing with a standard ESD control process.

### 7.3 Recommended Operating Conditions

Typical values for all parameters are at  $V_{DD} = 3.3V$  and  $T_A = 25^\circ C$ . (Temperature limits are specified by design)

		MIN	TYP	MAX	UNIT
$V_{DD}$	Supply voltage	3.0	3.3	3.6	V
$V_{IH}$	Input high voltage (SEL Pin)	2.0		$V_{DD}$	V
$V_{IL}$	Input low voltage (SEL Pin)	-0.1		0.8	V
$V_{I/O\_Diff}$	Differential voltage (differential pins)	Switch I/O diff voltage		1.8	VPP
$V_{I/O\_CM}$	Common voltage (differential pins)	Switch I/O common mode voltage		2.0	V
$T_A$	Operating free-air temperature	Ambient temperature		70	°C

### 7.4 Thermal Information

THERMAL METRIC <sup>(1)</sup>		HD3SS3415	UNIT
		TQFN (RUA)	
		42 PINS	
$R_{\theta JA}$	Junction-to-ambient thermal resistance	53.8	°C/W
$R_{\theta JC(top)}$	Junction-to-case (top) thermal resistance	38.2	°C/W
$R_{\theta JB}$	Junction-to-board thermal resistance	21.9	°C/W
$\Psi_{JT}$	Junction-to-top characterization parameter	27.4	°C/W
$\Psi_{JB}$	Junction-to-board characterization parameter	5.6	°C/W
$R_{\theta JC(bot)}$	Junction-to-case (bottom) thermal resistance	27.3	°C/W

- (1) For more information about traditional and new thermal metrics, see the *Semiconductor and IC Package Thermal Metrics* application report, [SPRA953](#).

## 7.5 Electrical Characteristics

 $R_{SC}$  and  $R_{LOAD} = 50 \Omega$  and  $C_L = 50 \text{ pF}$ , over operating free-air temperature range (unless otherwise noted)

PARAMETER		TEST CONDITIONS	MIN	TYP	MAX	UNIT
<b>DEVICE PARAMETERS</b>						
$I_{IH}$	Input High Voltage (SEL)	$V_{DD} = 3.6 \text{ V}; V_{IN} = V_{DD}$			95	$\mu\text{A}$
$I_{IL}$	Input Low Voltage (SEL)	$V_{DD} = 3.6 \text{ V}; V_{IN} = \text{GND}$			1	$\mu\text{A}$
$I_{LK}$	Leakage Current (Differential I/O pins)	$V_{DD} = 3.6 \text{ V}; V_{IN} = 0 \text{ V}; V_{OUT} = 2 \text{ V}$ ( $I_{LK}$ On OPEN outputs) [Ports B and C]			130	$\mu\text{A}$
		$V_{DD} = 3.6 \text{ V}; V_{IN} = 2 \text{ V}; V_{OUT} = 0 \text{ V}$ ( $I_{LK}$ On OPEN outputs) [Port A]			4	
$I_{DD}$	Supply Current	$V_{DD} = 3.6 \text{ V}; \text{SEL} = V_{DD}/\text{GND}; \text{Outputs Floating}$		4.7	6	mA
$C_{ON}$	Outputs ON Capacitance	$V_{IN} = 0 \text{ V}; \text{Outputs Open}; \text{Switch ON}$		1.5		pF
$C_{OFF}$	Outputs OFF Capacitance	$V_{IN} = 0 \text{ V}; \text{Outputs Open}, \text{Switch OFF}$		1		pF
$R_{ON}$	Output ON resistance	$V_{DD} = 3.3 \text{ V}; V_{CM} = 0.5 \text{ V to } 1.5 \text{ V}; I_O = -8 \text{ mA}$		5	8	$\Omega$
$\Delta R_{ON}$	On resistance match between channels	$V_{DD} = 3.3 \text{ V}; -0.35 \text{ V} \leq V_{IN} \leq 1.2 \text{ V}; I_O = -8 \text{ mA}$			2	$\Omega$
	On resistance match between pairs of the same channel	$V_{DD} = 3.3 \text{ V}; -0.35 \text{ V} \leq V_{IN} \leq 1.2 \text{ V}; I_O = -8 \text{ mA}$			0.7	$\Omega$
$R_{FLAT\_ON}$	On resistance flatness ( $R_{ON(MAX)} - R_{ON(MAIN)}$ )	$V_{DD} = 3.3 \text{ V}; -0.35 \text{ V} \leq V_{IN} \leq 1.2 \text{ V}$			1.15	$\Omega$
$t_{PD}$	Switch propagation delay	$R_{SC}$ and $R_{LOAD} = 50 \Omega$			85	ps
	SEL-to-switch $T_{on}$	$R_{SC}$ and $R_{LOAD} = 50 \Omega$		70	250	ns
	SEL-to-switch $T_{off}$			70	250	
$T_{SKEW\_inter}$	Inter-pair output skew (CH-CH)	$R_{SC}$ and $R_{LOAD} = 50 \Omega$			20	ps
$T_{SKEW\_intra}$	Intra-pair output skew (bit-bit)				8	ps
$R_L$	Differential return loss (VCM = 0 V) See <a href="#">Typical Characteristics</a>	$f = 0.3 \text{ MHz}$		-28		dB
		$f = 2500 \text{ MHz}$		-12		
		$f = 4000 \text{ MHz}$		-11		
$X_{TALK}$	Differential Crosstalk (VCM = 0 V) See <a href="#">Typical Characteristics</a>	$f = 0.3 \text{ MHz}$		-90		dB
		$f = 2500 \text{ MHz}$		-39		
		$f = 4000 \text{ MHz}$		-35		
$O_{IRR}$	Differential Off-Isolation (VCM = 0 V) See <a href="#">Typical Characteristics</a>	$f = 0.3 \text{ MHz}$		-75		dB
		$f = 2500 \text{ MHz}$		-22		
		$f = 4000 \text{ MHz}$		-19		
$I_L$	Differential Insertion Loss (VCM = 0 V) See <a href="#">Typical Characteristics</a>	$f = 0.3 \text{ MHz}$		-0.5		dB
		$f = 2500 \text{ MHz}$		-1.1		
		$f = 4000 \text{ MHz}$		-1.5		
BW	Band Width	At -3 dB		8		GHz

## 7.6 Dissipation Ratings

		MIN	MAX	UNIT
$P_D$	Power Dissipation	15.5	21.6	mW

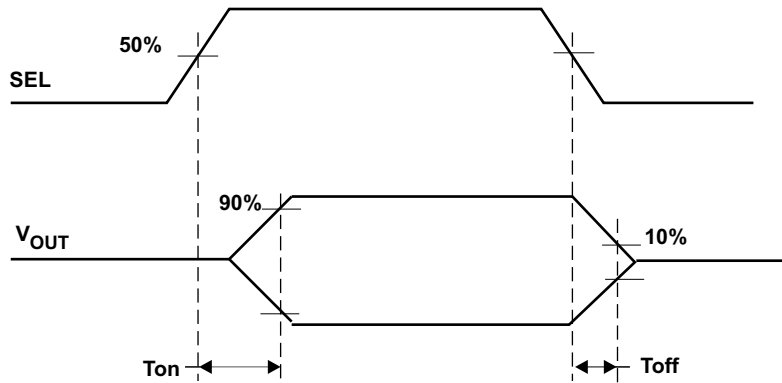
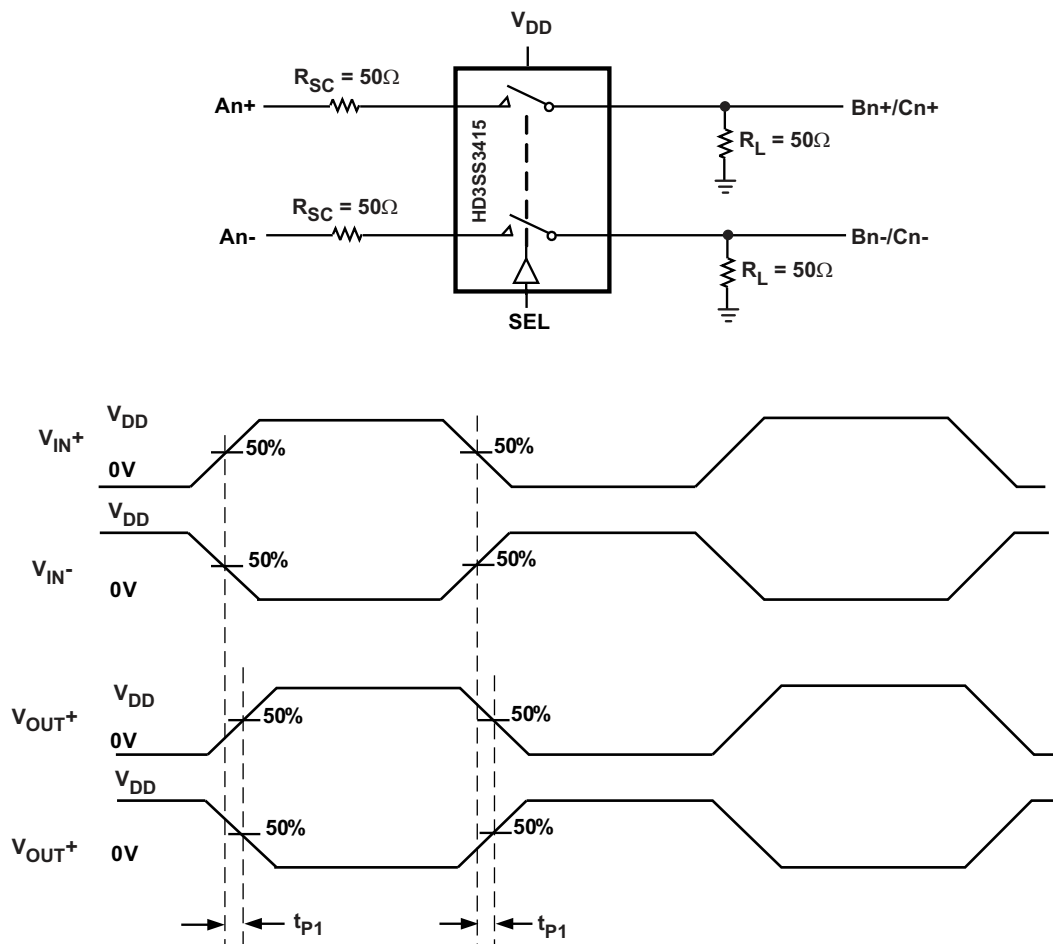

Figure 1. Select to Switch Output On ( $T_{ON}$ ) and Off ( $T_{OFF}$ ) Timing Diagram



$T_{SKEWinter}$  = Difference between  $t_{pD}$  for any two pairs of outputs

$T_{SKEWintra}$  = Difference between  $t_{p1}$  and  $t_{p2}$  of same pair

Figure 2. Propagation Delay Timing Diagram and Test Setup



## 7.7 Typical Characteristics

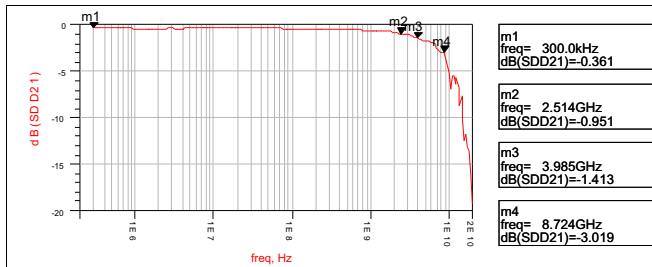

Figure 3. Differential Insertion Loss

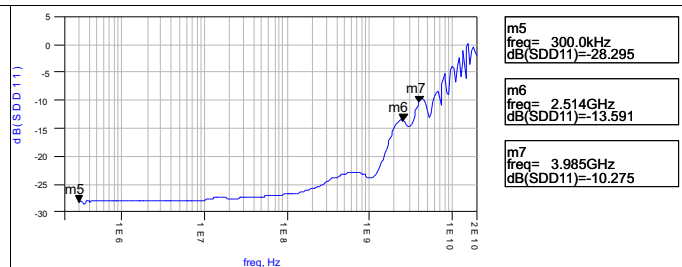

Figure 4. Differential Return Loss

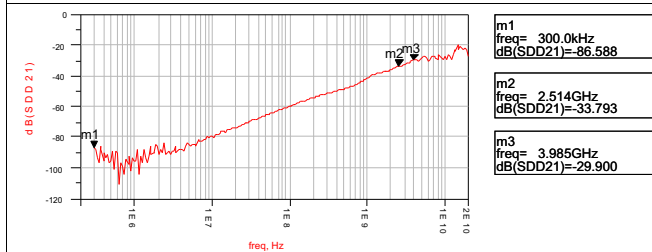

Figure 5. Differential Crosstalk

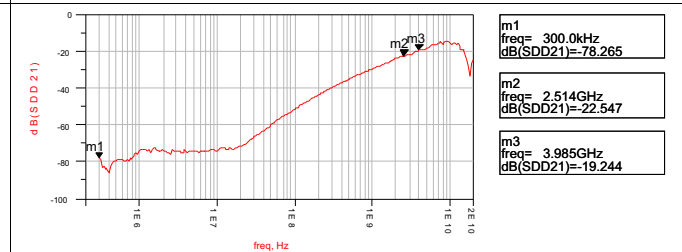
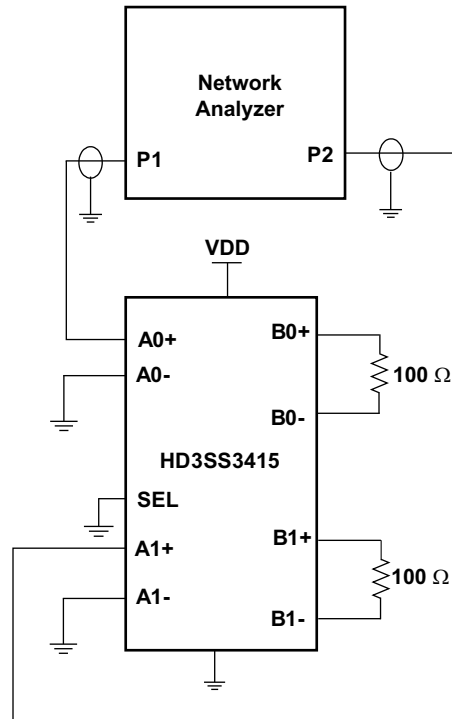
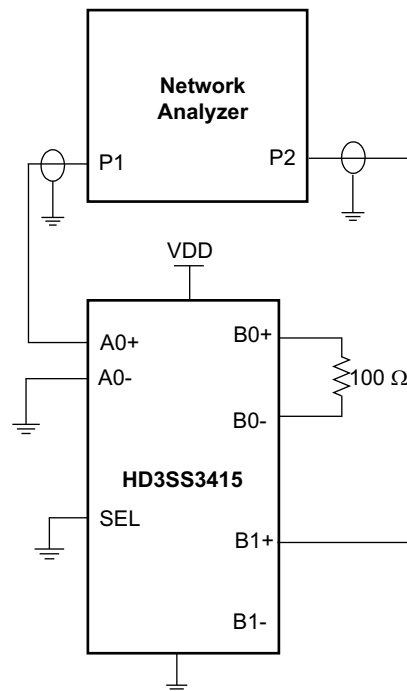

Figure 6. Differential Off Isolation

## 8 Parameter Measurement Information



**Figure 7. Cross Talk Measurement Setup**



**Figure 8. Off Isolation Measurement Setup**

Parameter Measurement Information (continued)

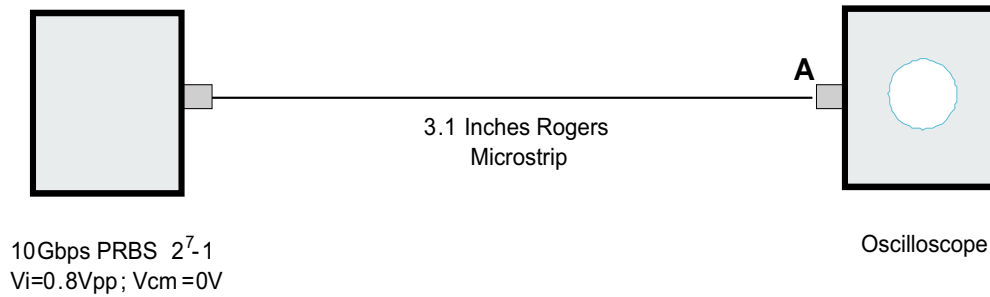

Figure 9. Source Eye Diagram Test Setup

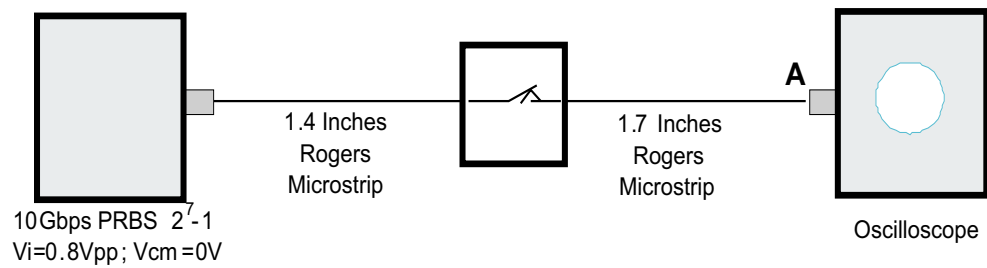

Figure 10. Output Eye Diagram Test Setup

## 9 Detailed Description

### 9.1 Overview

The HD3SS3415 is a high-speed passive switch offered in an industry standard 42-pin WQFN package available in a common footprint shared by several other vendors. The device is specified to operate from a single supply voltage of 3.3 V over the full industrial temperature range of 0°C to 70°C. The HD3SS3415 is a generic 4-CH high-speed mux/demux type of switch that can be used for routing high-speed PCI signals between two different locations on a circuit board. Although it was designed specifically to address PCI Express Gen III applications, the HD3SS3415 will also support several other high-speed data protocols with a differential amplitude of < 1800 mV<sub>pp</sub> and a common-mode voltage of < 2.0 V, as with USB 3.0 and DisplayPort 1.2.

### 9.2 Functional Block Diagram

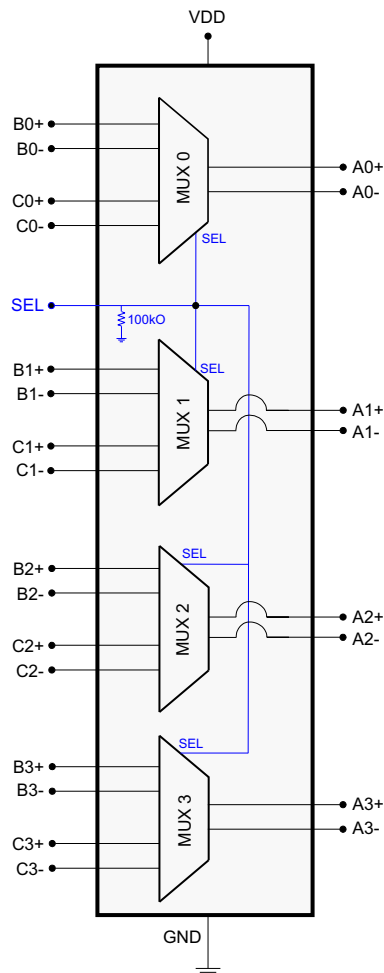

### 9.3 Feature Description

The HD3SS3415 has a single control line (SEL Pin) which can be used to control the signal path between Port A and either Port B or Port C. The one select input (SEL) pin of the device can easily be controlled by an available GPIO pin within a system or from a microcontroller.

**Table 1. MUX Pin Connections<sup>(1)</sup>**

PORT A CHANNEL	PORT B OR PORT C CHANNEL CONNECTED TO PORT A CHANNEL	
	SEL = L	SEL = H
A0+	B0+	C0+
A0–	B0–	C0–
A1+	B1+	C1+
A1–	B1–	C1–
A2+	B2+	C2+
A2–	B2–	C2–
A3+	B3+	C3+
A3–	B3–	C3–

(1) The HD3SS3415 can tolerate polarity inversions for all differential signals on Ports A, B and C. Care should be taken to ensure the same polarity is maintained on Port A vs. Port B/C.

### 9.4 Device Functional Modes

[Table 2](#) lists the functional modes for the HD3SS3415.

**Table 2. HD3SS3415 Control Logic**

CONTROL PIN (SEL)	PORT A TO PORT B CONNECTION STATUS	PORT A TO PORT C CONNECTION STATUS
L (Default State)	Connected	Disconnected
H	Disconnected	Connected

## 10 Application and Implementation

### NOTE

Information in the following applications sections is not part of the TI component specification, and TI does not warrant its accuracy or completeness. TI's customers are responsible for determining suitability of components for their purposes. Customers should validate and test their design implementation to confirm system functionality.

### 10.1 Application Information

#### 10.1.1 AC Coupling Caps

Many interfaces require AC coupling between the transmitter and receiver. The 0402 capacitors are the preferred option to provide AC coupling, and the 0603 size capacitors also work. The 0805 size capacitors and C-packs should be avoided. When placing AC coupling capacitors symmetric placement is best. A capacitor value of 0.1  $\mu\text{F}$  is best and the value should be match for the  $\pm$  signal pair. The placement should be along the TX pairs on the system board, which are usually routed on the top layer of the board.

There are several placement options for the AC coupling capacitors. Because the switch requires a bias voltage, the capacitors must only be placed on one side of the switch. If they are placed on both sides of the switch, a biasing voltage should be provided. A few placement options are shown below. In [Figure 11](#), the coupling capacitors are placed between the switch and endpoint. In this situation, the switch is biased by the system/host controller.

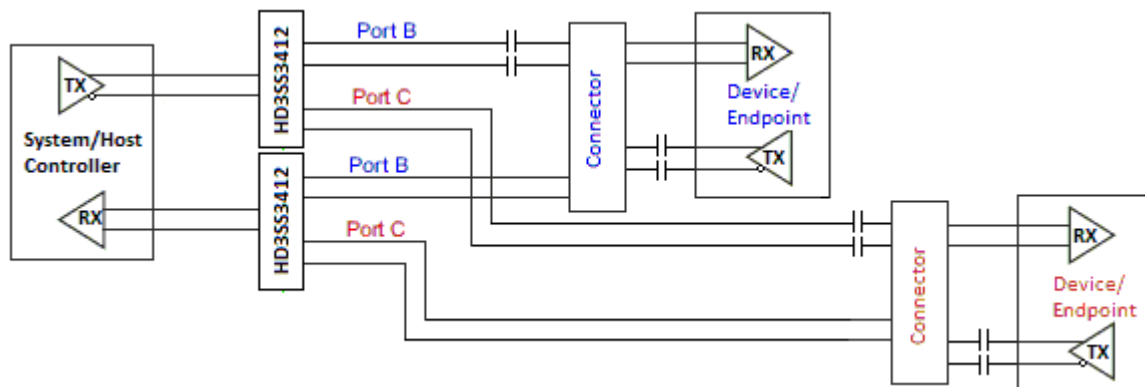

**Figure 11. AC Coupling Capacitors Between Switch Tx and Endpoint Tx**

In [Figure 12](#), the coupling capacitors are placed on the host transmit pair and endpoint transmit pair. In this situation, the switch on the top is biased by the endpoint and the lower switch is biased by the host controller.

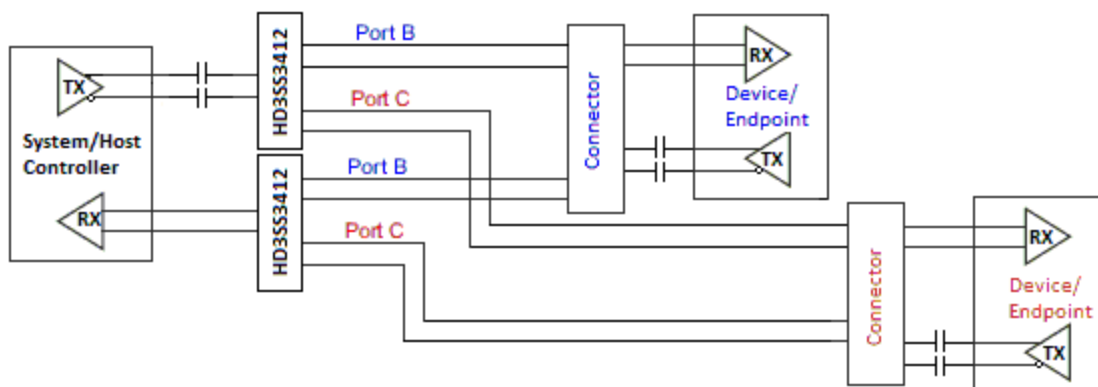

**Figure 12. AC Coupling Capacitors on Host Tx and Endpoint Tx**

### Application Information (continued)

If the common-mode voltage in the system is higher than 2 V, the coupling capacitors are placed on both sides of the switch (shown in Figure 13). A biasing voltage of less than 2 V is required in this case.

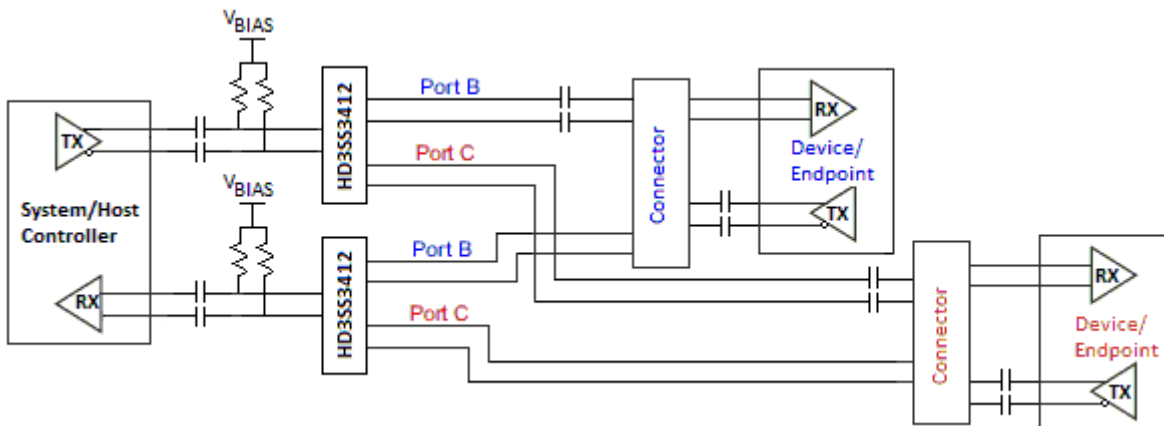

Figure 13. AC Coupling Capacitors on Both Sides of Switch

## 10.2 Typical Application

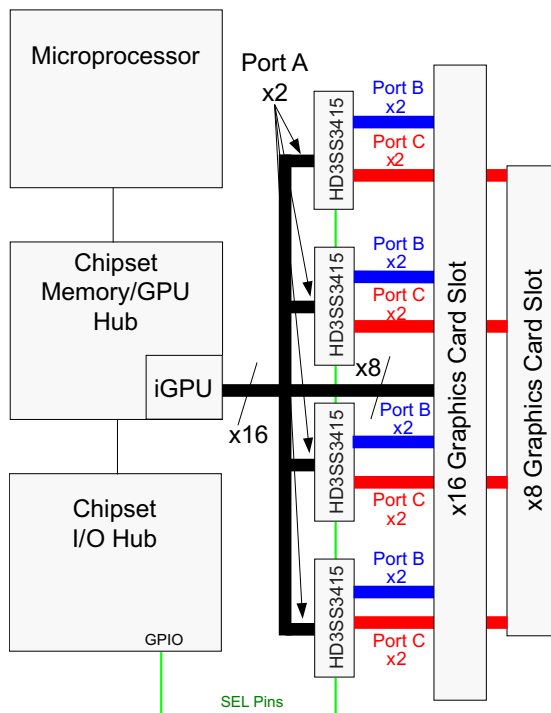

Figure 14. Typical Application Schematic

## Typical Application (continued)

### 10.2.1 Design Requirements

Table 3 lists the design parameters of this example.

**Table 3. Design Parameters**

DESIGN PARAMETER	EXAMPLE VALUE
Input voltage range	3.3 V
Decoupling capacitors	0.1 $\mu$ F
AC Capacitors	75 nF - 200 nF (100 nF shown) USBSS TX p and n lines require AC capacotprs. Alternate mode signals may or may not require AC capacitors

### 10.2.2 Detailed Design Procedure

- Connect VDD and GND pins to the power and ground planes of the printed circuit board, with a 0.1-uF bypass capacitor.
- Use +3.3-V TTL/CMOS logic level at SEL
- Use controlled-impedance transmission media for all the differential signals
- Ensure the received complimentary signals are with a differential amplitude of <1800 mVpp and a common-mode voltage of <2 V

### 10.2.3 Application Curves

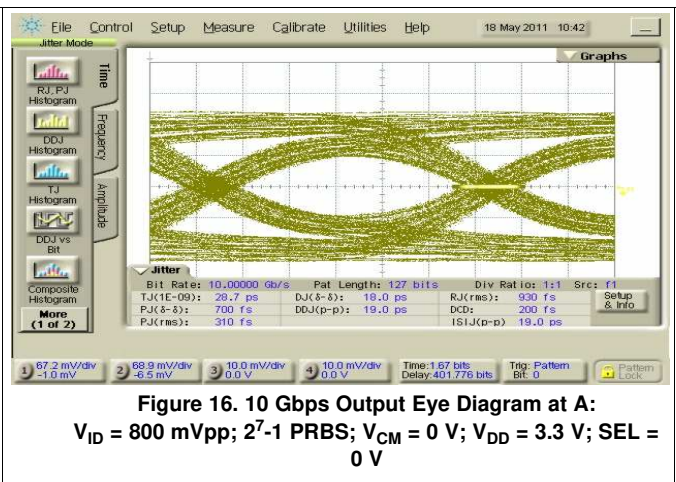
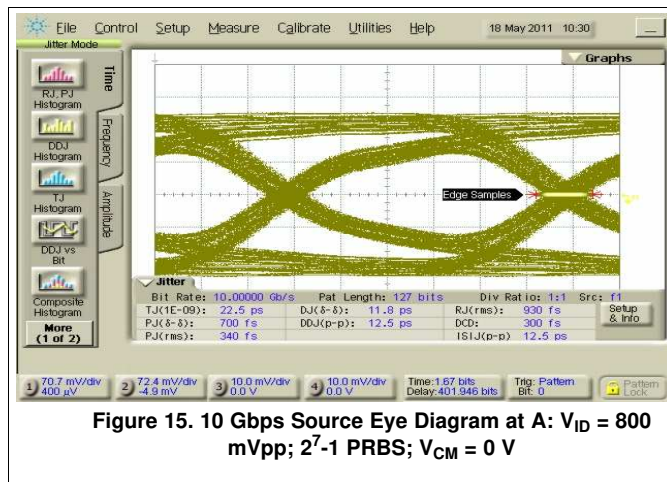



## 11 Power Supply Recommendations

The HD3SS3415 requires +3.3-V digital power sources. VDD 3.3 supply must have 0.1- $\mu$ F bypass capacitors to VSS (ground) for proper operation. TI recommends one capacitor for each power terminal. Place the capacitor as close as possible to the terminal on the device and keep trace length to a minimum. Smaller value capacitors such as 0.01- $\mu$ F are also recommended on the digital supply terminals.

## 12 Layout

### 12.1 Layout Guidelines

- Decoupling caps should be placed next to each power terminal on the HD3SS3415. Take care to minimize the stub length of the trace connecting the capacitor to the power pin.
- Avoid sharing vias between multiple decoupling caps.
- Place vias as close as possible to the decoupling cap solder pad.
- Widen VDD/GND planes to reduce effect of static and dynamic IR drop.
- The VBUS traces/planes must be wide enough to carry maximum of 2 A current

### 12.2 Layout Example

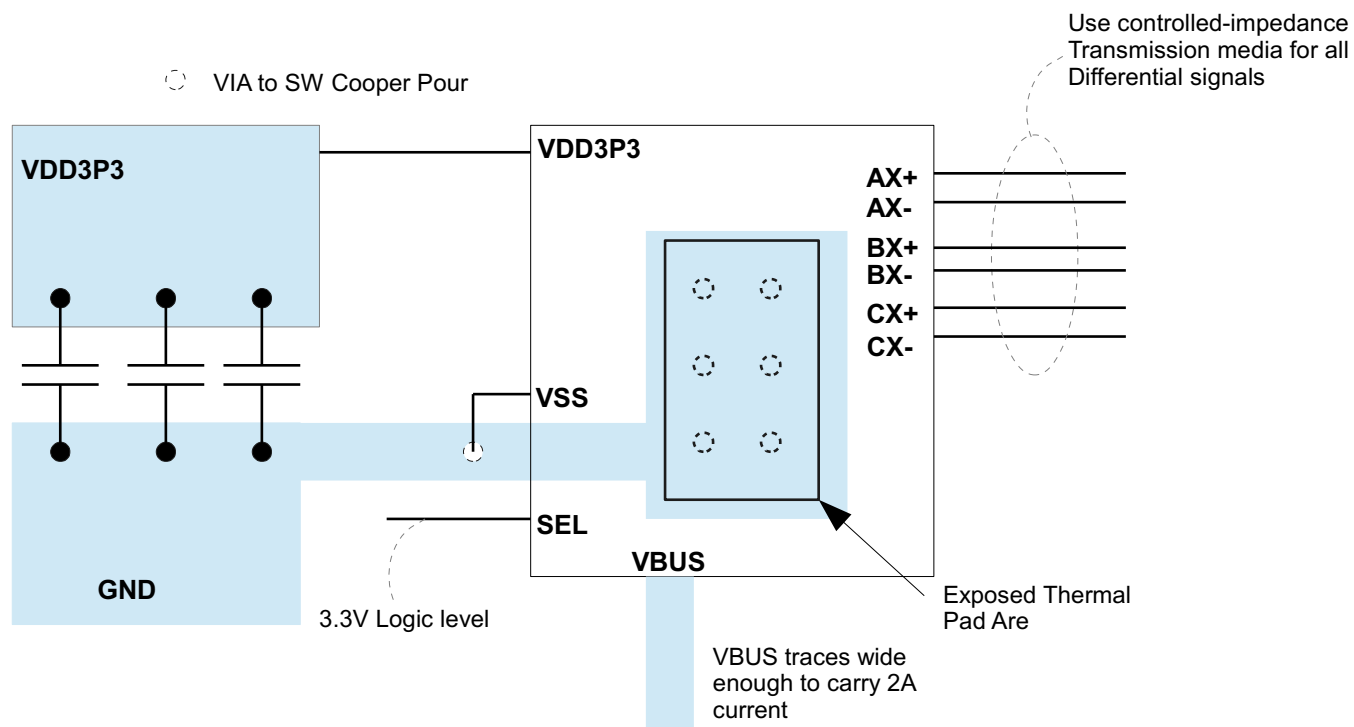

Figure 17. Layout Example

## 13 Device and Documentation Support

### 13.1 Community Resources

The following links connect to TI community resources. Linked contents are provided "AS IS" by the respective contributors. They do not constitute TI specifications and do not necessarily reflect TI's views; see TI's [Terms of Use](#).

**TI E2E™ Online Community** *TI's Engineer-to-Engineer (E2E) Community*. Created to foster collaboration among engineers. At [e2e.ti.com](http://e2e.ti.com), you can ask questions, share knowledge, explore ideas and help solve problems with fellow engineers.

**Design Support** *TI's Design Support* Quickly find helpful E2E forums along with design support tools and contact information for technical support.

### 13.2 Trademarks

E2E is a trademark of Texas Instruments.  
All other trademarks are the property of their respective owners.

### 13.3 Electrostatic Discharge Caution



These devices have limited built-in ESD protection. The leads should be shorted together or the device placed in conductive foam during storage or handling to prevent electrostatic damage to the MOS gates.

### 13.4 Glossary

[SLYZ022](#) — *TI Glossary*.

This glossary lists and explains terms, acronyms, and definitions.

## 14 Mechanical, Packaging, and Orderable Information

The following pages include mechanical, packaging, and orderable information. This information is the most current data available for the designated devices. This data is subject to change without notice and revision of this document. For browser-based versions of this data sheet, refer to the left-hand navigation.

**PACKAGING INFORMATION**

Orderable Device	Status (1)	Package Type	Package Drawing	Pins	Package Qty	Eco Plan (2)	Lead finish/ Ball material (6)	MSL Peak Temp (3)	Op Temp (°C)	Device Marking (4/5)	Samples
HD3SS3415RUAR	ACTIVE	WQFN	RUA	42	3000	RoHS & Green	NIPDAU	Level-2-260C-1 YEAR	0 to 70	HD3SS3415	<a href="#">Samples</a>
HD3SS3415RUAT	ACTIVE	WQFN	RUA	42	250	RoHS & Green	NIPDAU	Level-2-260C-1 YEAR	0 to 70	HD3SS3415	<a href="#">Samples</a>

(1) The marketing status values are defined as follows:

**ACTIVE:** Product device recommended for new designs.

**LIFEBUY:** TI has announced that the device will be discontinued, and a lifetime-buy period is in effect.

**NRND:** Not recommended for new designs. Device is in production to support existing customers, but TI does not recommend using this part in a new design.

**PREVIEW:** Device has been announced but is not in production. Samples may or may not be available.

**OBSOLETE:** TI has discontinued the production of the device.

(2) **RoHS:** TI defines "RoHS" to mean semiconductor products that are compliant with the current EU RoHS requirements for all 10 RoHS substances, including the requirement that RoHS substance do not exceed 0.1% by weight in homogeneous materials. Where designed to be soldered at high temperatures, "RoHS" products are suitable for use in specified lead-free processes. TI may reference these types of products as "Pb-Free".

**RoHS Exempt:** TI defines "RoHS Exempt" to mean products that contain lead but are compliant with EU RoHS pursuant to a specific EU RoHS exemption.

**Green:** TI defines "Green" to mean the content of Chlorine (Cl) and Bromine (Br) based flame retardants meet JS709B low halogen requirements of <=1000ppm threshold. Antimony trioxide based flame retardants must also meet the <=1000ppm threshold requirement.

(3) MSL, Peak Temp. - The Moisture Sensitivity Level rating according to the JEDEC industry standard classifications, and peak solder temperature.

(4) There may be additional marking, which relates to the logo, the lot trace code information, or the environmental category on the device.

(5) Multiple Device Markings will be inside parentheses. Only one Device Marking contained in parentheses and separated by a "~" will appear on a device. If a line is indented then it is a continuation of the previous line and the two combined represent the entire Device Marking for that device.

(6) Lead finish/Ball material - Orderable Devices may have multiple material finish options. Finish options are separated by a vertical ruled line. Lead finish/Ball material values may wrap to two lines if the finish value exceeds the maximum column width.

**Important Information and Disclaimer:**The information provided on this page represents TI's knowledge and belief as of the date that it is provided. TI bases its knowledge and belief on information provided by third parties, and makes no representation or warranty as to the accuracy of such information. Efforts are underway to better integrate information from third parties. TI has taken and continues to take reasonable steps to provide representative and accurate information but may not have conducted destructive testing or chemical analysis on incoming materials and chemicals. TI and TI suppliers consider certain information to be proprietary, and thus CAS numbers and other limited information may not be available for release.

In no event shall TI's liability arising out of such information exceed the total purchase price of the TI part(s) at issue in this document sold by TI to Customer on an annual basis.

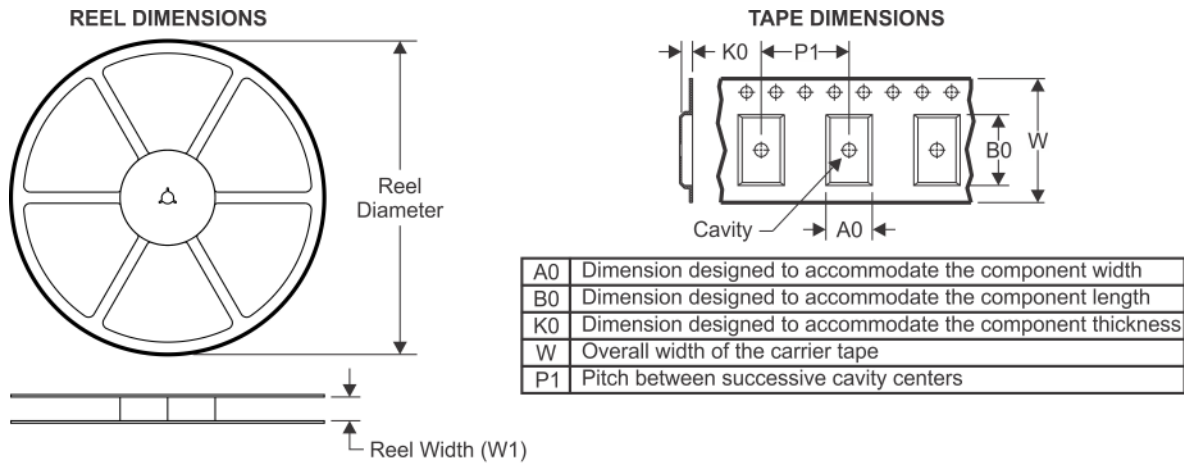
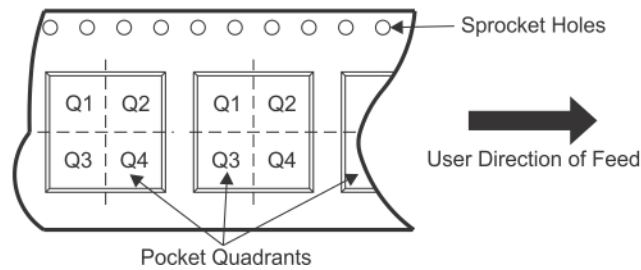

**TAPE AND REEL INFORMATION**

**QUADRANT ASSIGNMENTS FOR PIN 1 ORIENTATION IN TAPE**

\*All dimensions are nominal

Device	Package Type	Package Drawing	Pins	SPQ	Reel Diameter (mm)	Reel Width W1 (mm)	A0 (mm)	B0 (mm)	K0 (mm)	P1 (mm)	W (mm)	Pin1 Quadrant
HD3SS3415RUAR	WQFN	RUA	42	3000	330.0	16.4	3.8	9.3	1.0	8.0	16.0	Q1
HD3SS3415RUAT	WQFN	RUA	42	250	180.0	16.4	3.8	9.3	1.0	8.0	16.0	Q1

**TAPE AND REEL BOX DIMENSIONS**

\*All dimensions are nominal

Device	Package Type	Package Drawing	Pins	SPQ	Length (mm)	Width (mm)	Height (mm)
HD3SS3415RUAR	WQFN	RUA	42	3000	367.0	367.0	38.0
HD3SS3415RUAT	WQFN	RUA	42	250	210.0	185.0	35.0

## GENERIC PACKAGE VIEW

**RUA 42**

**WQFN - 0.8 mm max height**

9 x 3.5, 0.5 mm pitch

PLASTIC QUAD FLATPACK - NO LEAD

This image is a representation of the package family, actual package may vary.  
Refer to the product data sheet for package details.

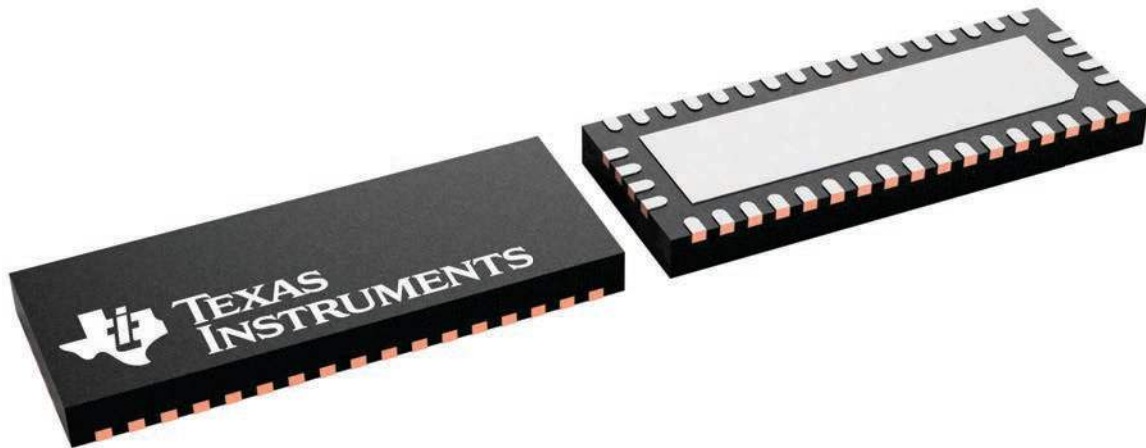

4226504/A

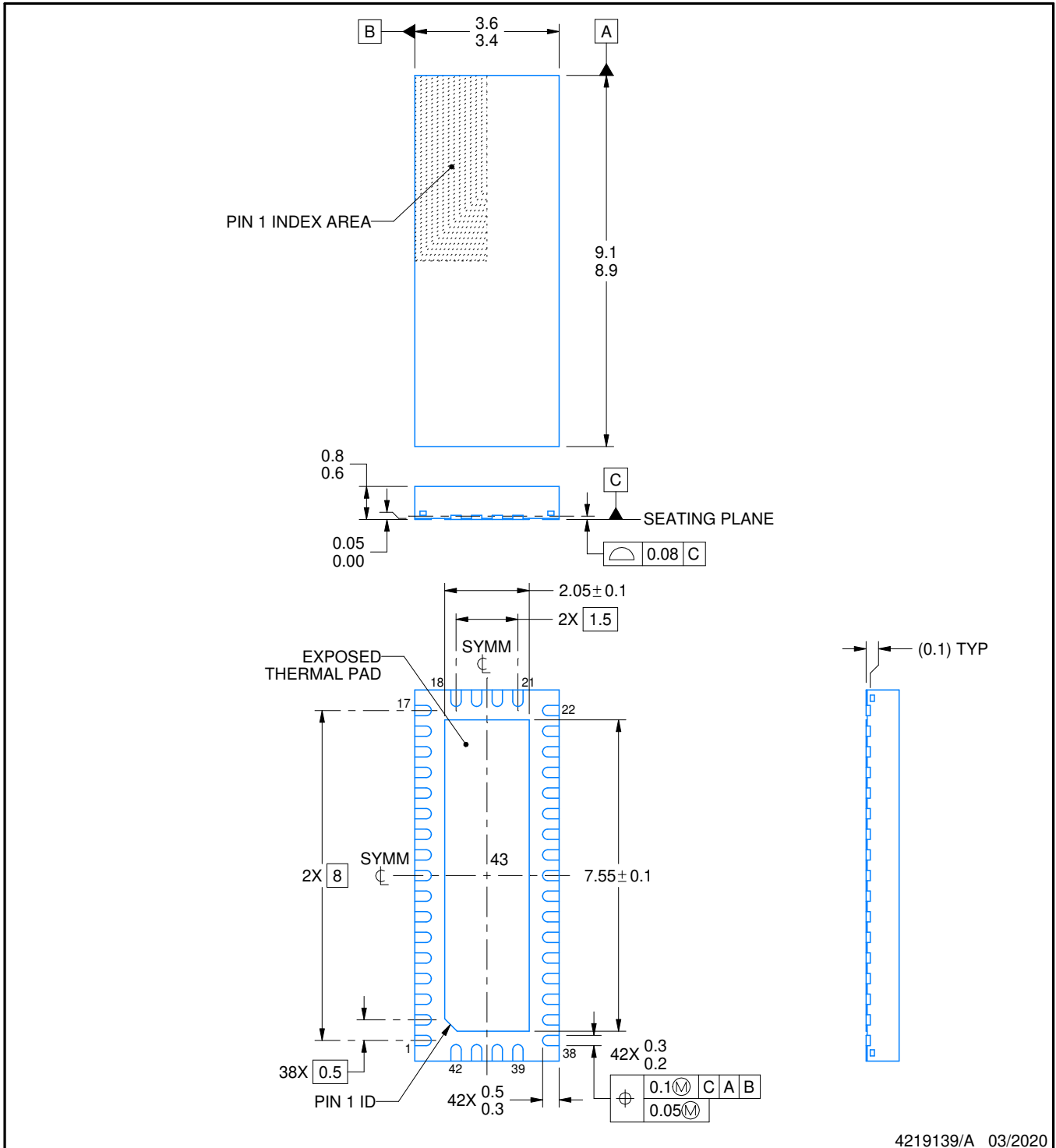

4219139/A 03/2020

NOTES:

1. All linear dimensions are in millimeters. Any dimensions in parenthesis are for reference only. Dimensioning and tolerancing per ASME Y14.5M.
2. This drawing is subject to change without notice.
3. The package thermal pad must be soldered to the printed circuit board for thermal and mechanical performance.





# EXAMPLE STENCIL DESIGN

RUA0042A

WQFN - 0.8 mm max height

PLASTIC QUAD FLATPACK - NO LEAD

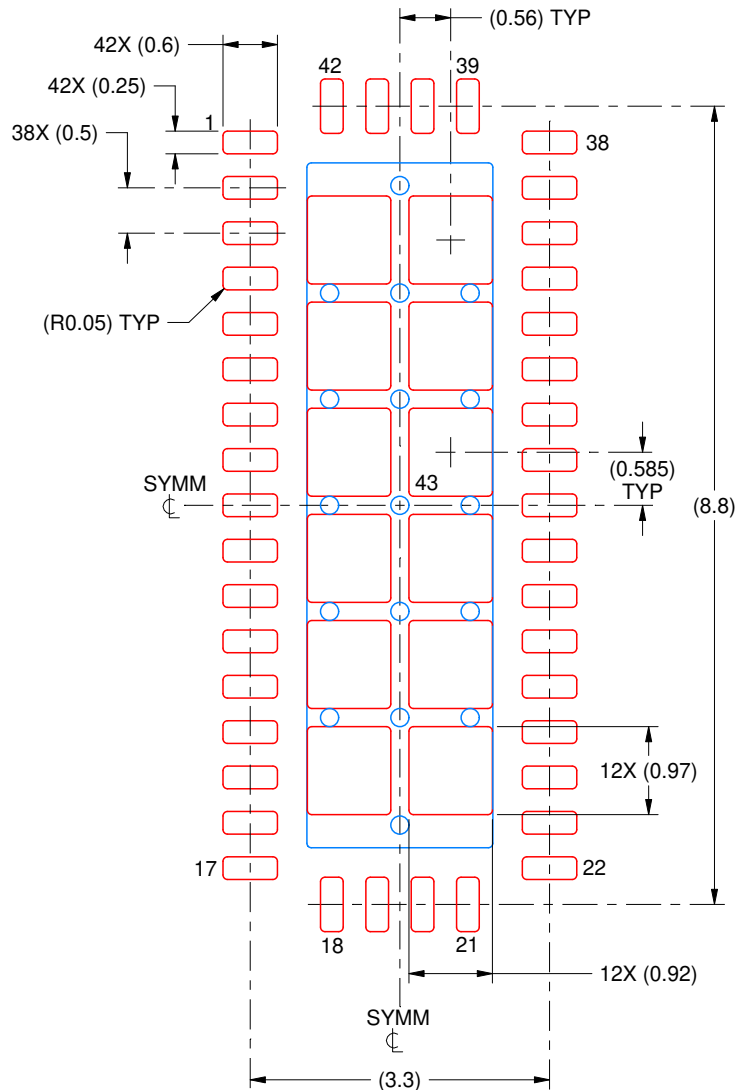

SOLDER PASTE EXAMPLE  
BASED ON 0.125 MM THICK STENCIL  
SCALE: 12X

EXPOSED PAD 43  
69% PRINTED SOLDER COVERAGE BY AREA UNDER PACKAGE

4219139/A 03/2020

NOTES: (continued)

6. Laser cutting apertures with trapezoidal walls and rounded corners may offer better paste release. IPC-7525 may have alternate design recommendations.

## IMPORTANT NOTICE AND DISCLAIMER

TI PROVIDES TECHNICAL AND RELIABILITY DATA (INCLUDING DATASHEETS), DESIGN RESOURCES (INCLUDING REFERENCE DESIGNS), APPLICATION OR OTHER DESIGN ADVICE, WEB TOOLS, SAFETY INFORMATION, AND OTHER RESOURCES "AS IS" AND WITH ALL FAULTS, AND DISCLAIMS ALL WARRANTIES, EXPRESS AND IMPLIED, INCLUDING WITHOUT LIMITATION ANY IMPLIED WARRANTIES OF MERCHANTABILITY, FITNESS FOR A PARTICULAR PURPOSE OR NON-INFRINGEMENT OF THIRD PARTY INTELLECTUAL PROPERTY RIGHTS.

These resources are intended for skilled developers designing with TI products. You are solely responsible for (1) selecting the appropriate TI products for your application, (2) designing, validating and testing your application, and (3) ensuring your application meets applicable standards, and any other safety, security, or other requirements. These resources are subject to change without notice. TI grants you permission to use these resources only for development of an application that uses the TI products described in the resource. Other reproduction and display of these resources is prohibited. No license is granted to any other TI intellectual property right or to any third party intellectual property right. TI disclaims responsibility for, and you will fully indemnify TI and its representatives against, any claims, damages, costs, losses, and liabilities arising out of your use of these resources.

TI's products are provided subject to TI's Terms of Sale (<https://www.ti.com/legal/termsofsale.html>) or other applicable terms available either on [ti.com](https://www.ti.com) or provided in conjunction with such TI products. TI's provision of these resources does not expand or otherwise alter TI's applicable warranties or warranty disclaimers for TI products.

Mailing Address: Texas Instruments, Post Office Box 655303, Dallas, Texas 75265  
Copyright © 2021, Texas Instruments Incorporated