

PRODUCT NUMBER	MATING LENGTH, DIM "X" (REF)				ROHS COMPATIBILITY
	POSN 1	POSN 2	POSN 3	POSN 4	
10025058-1222	1.10	2.60	2.60	2.60	N/A
10025058-1122	1.10	1.10	2.60	2.60	N/A
10025058-2122	2.60	1.10	2.60	2.60	N/A
10025058-2111	2.60	1.10	1.10	1.10	N/A
10025058-2112	2.60	1.10	1.10	2.60	N/A
10025058-1222LF	1.10	2.60	2.60	2.60	SEE NOTE 8
10025058-1122LF	1.10	1.10	2.60	2.60	SEE NOTE 8
10025058-2122LF	2.60	1.10	2.60	2.60	SEE NOTE 8
10025058-2111LF	2.60	1.10	1.10	1.10	SEE NOTE 8
10025058-2112LF	2.60	1.10	1.10	2.60	SEE NOTE 8

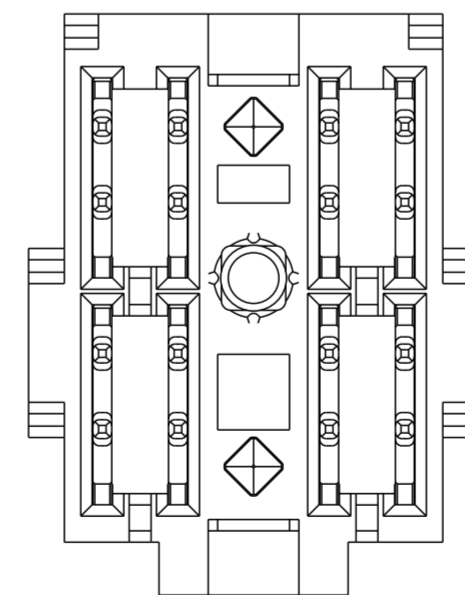
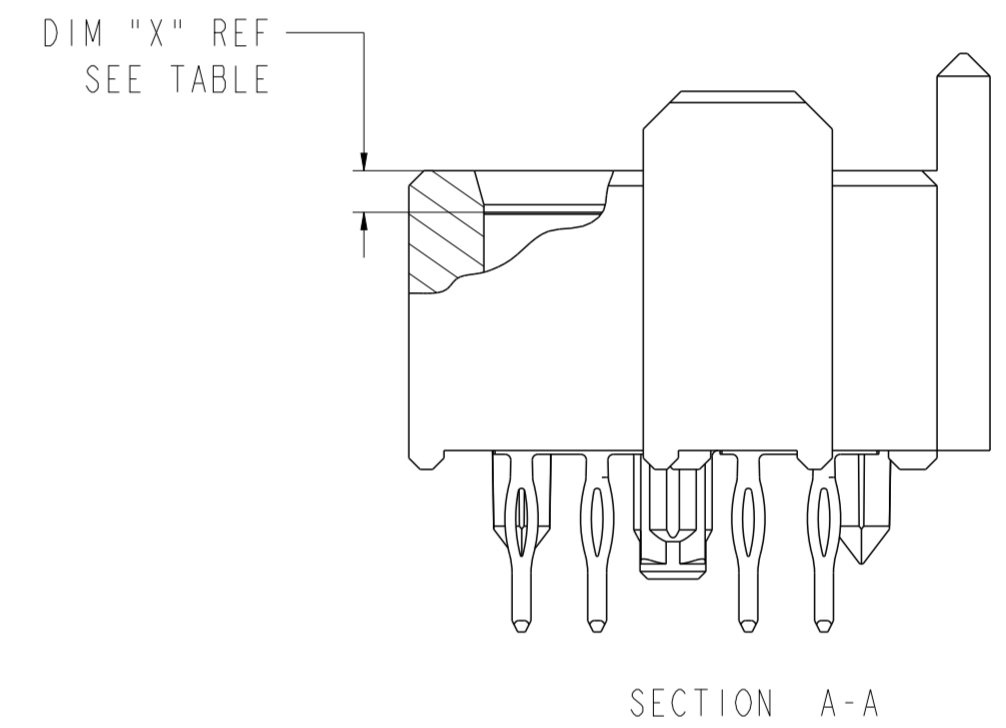
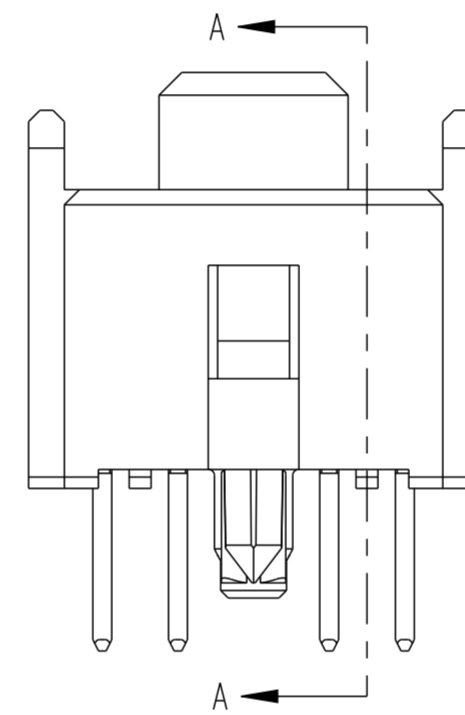
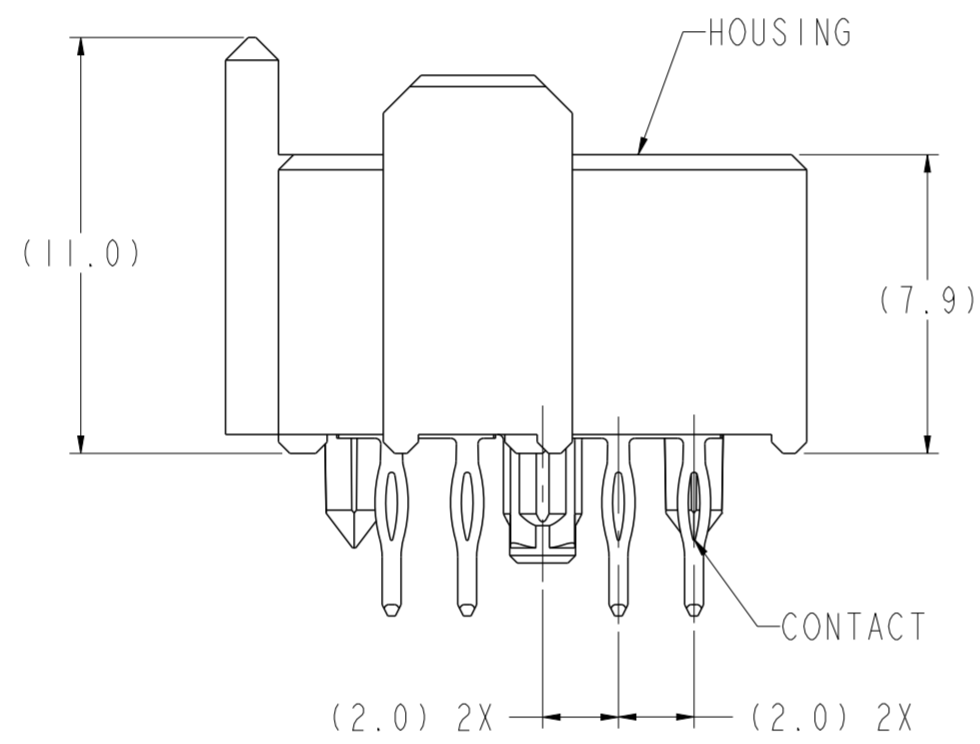
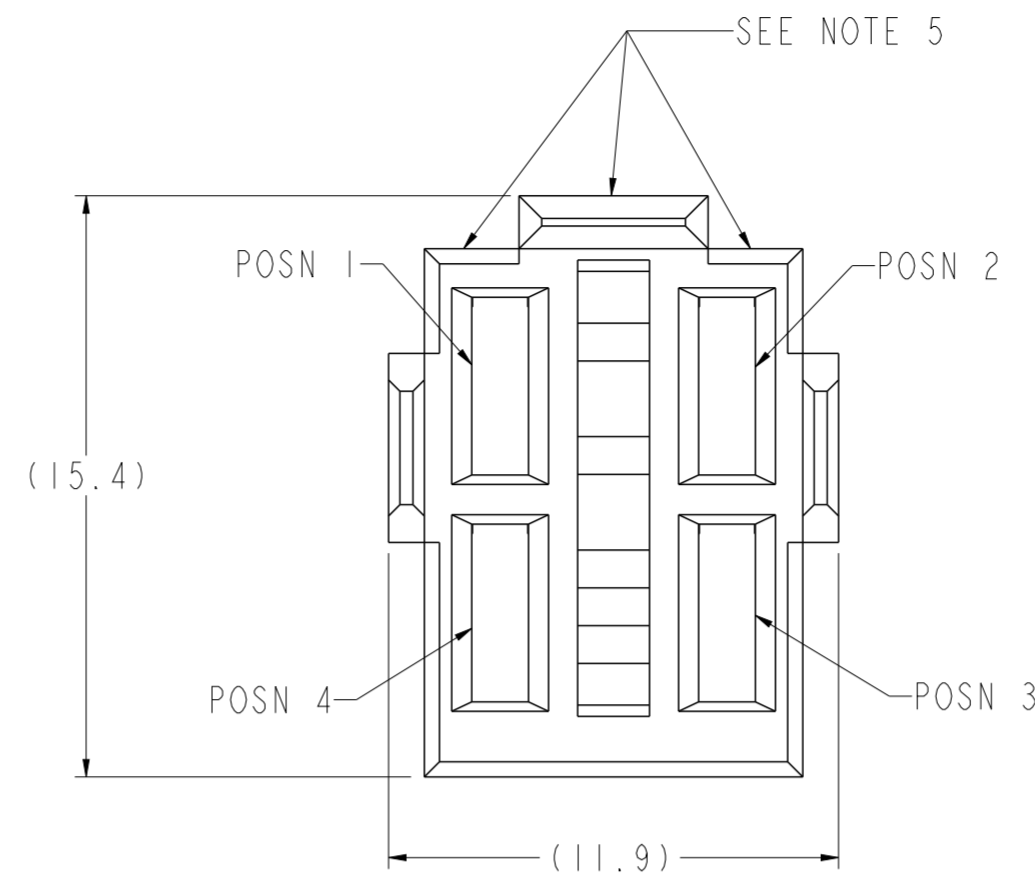

spec ref	GS-12-220	dr	Chen-Hong Tan	2005/08/03	projection	MM	size	A2	scale	5:1	
tolerance std	ASME Y14.5	eng	Suzie Nah	2013/12/25			ecn no	ELX-S-16550-1			
TOLERANCES UNLESS OTHERWISE SPECIFIED		chr	-	appr			Chen-Hong Tan	2014/01/14	product family	2mm High Power	rel level
surface	3/2	linear	0.X	±0.3			title	2 X 2 RECEPTACLE		rev	K
			0.XX	±0.10	www.fci.com	cat. no.	-	Product - Customer	Drw	sheet 1 of 2	
		angular	0°	±2°			dwg no	10025058			

PDS: Rev :K

STATUS:Released

Printed: Jan 14, 2014

