

28 WAY CONNECTOR ASSY  
KEY 1  
P/N 1600140011

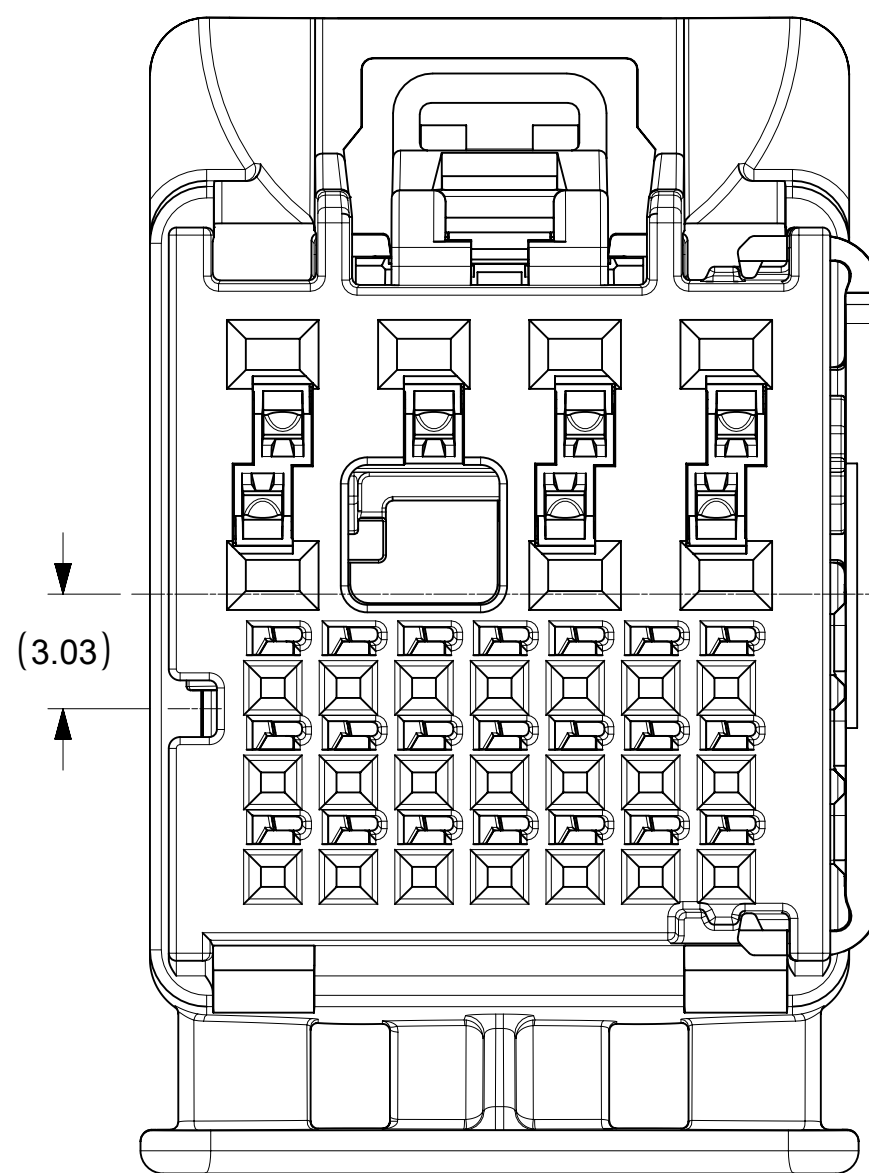

28 WAY CONNECTOR ASSY  
KEY 2  
P/N 1600140012

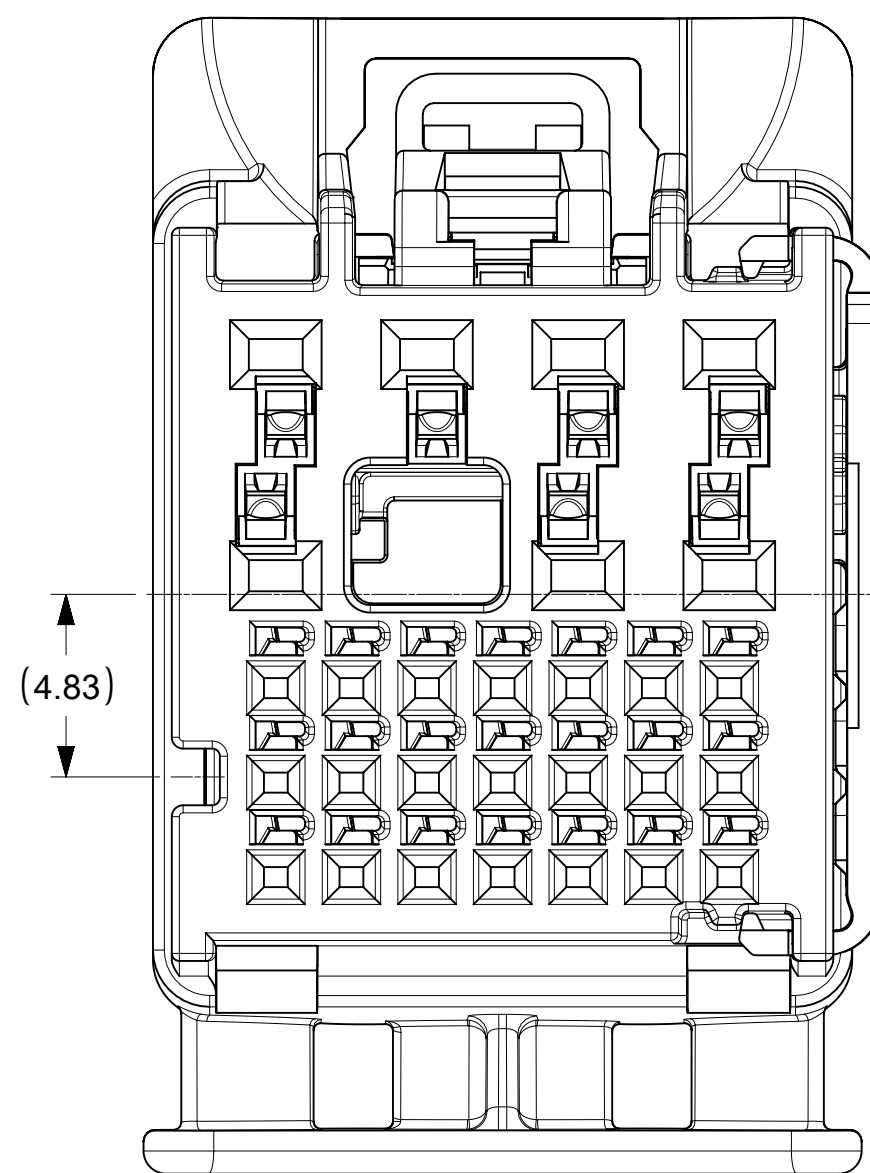

28 WAY CONNECTOR ASSY  
KEY 3  
P/N 1600140013

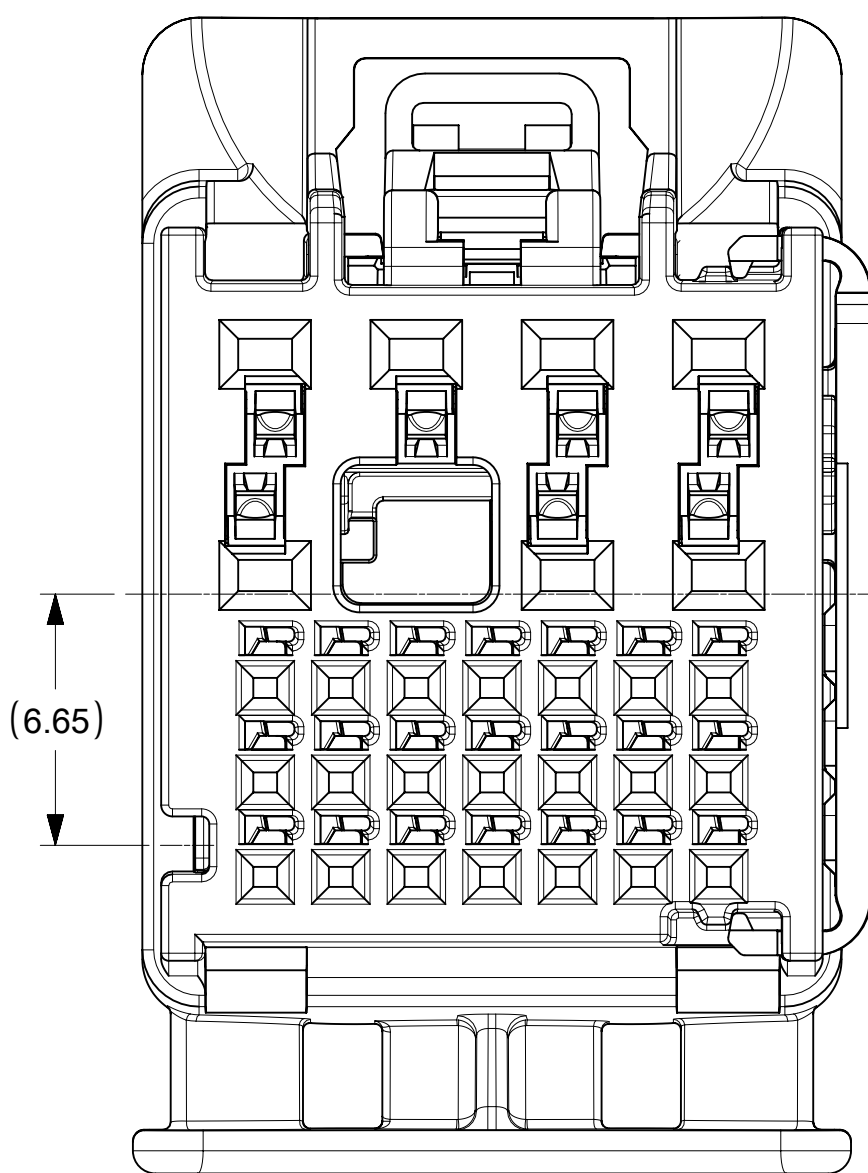

28 WAY CONNECTOR ASSY  
KEY 4  
P/N 1600140014

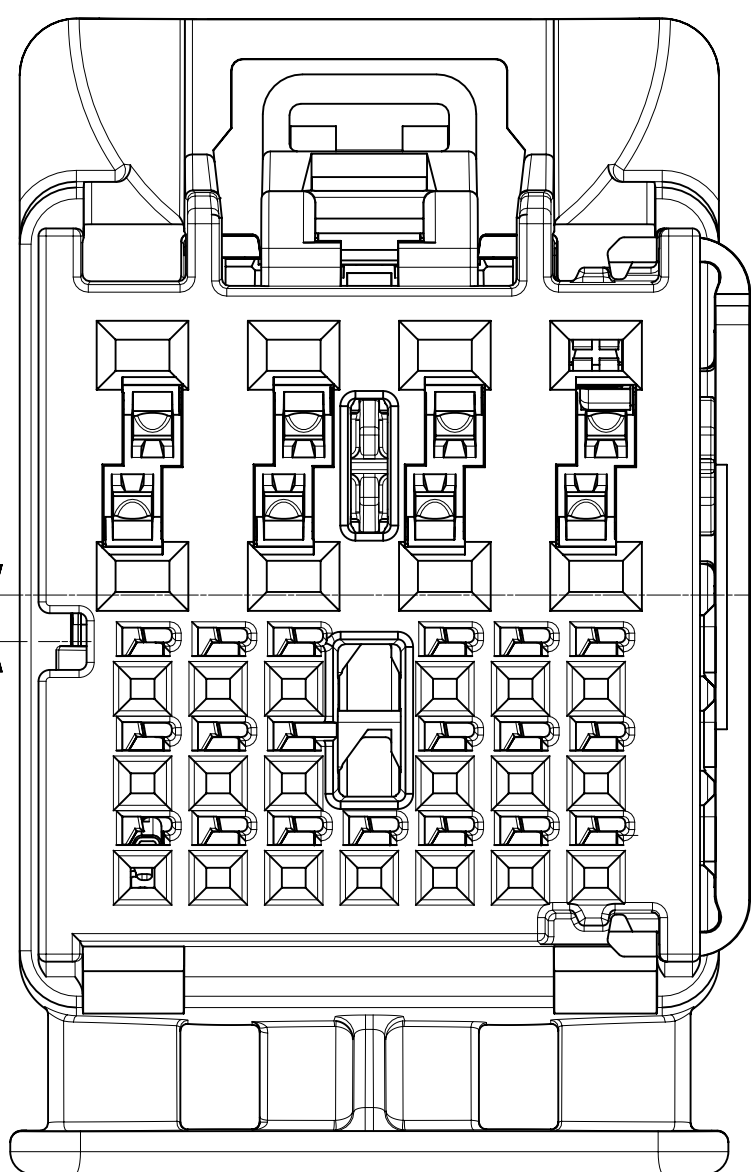

27 WAY CONNECTOR ASSY  
KEY 1  
P/N 1600290011

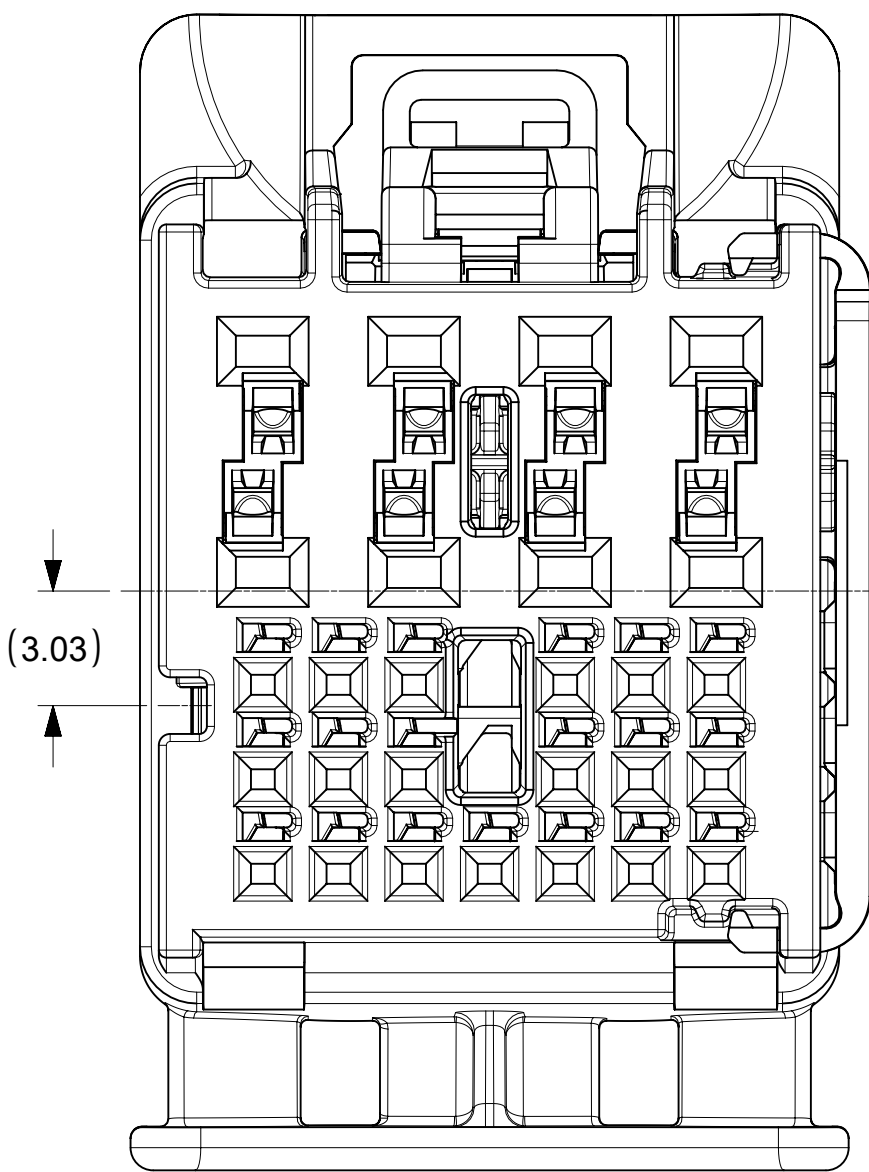

27 WAY CONNECTOR ASSY  
KEY 2  
P/N 1600290012

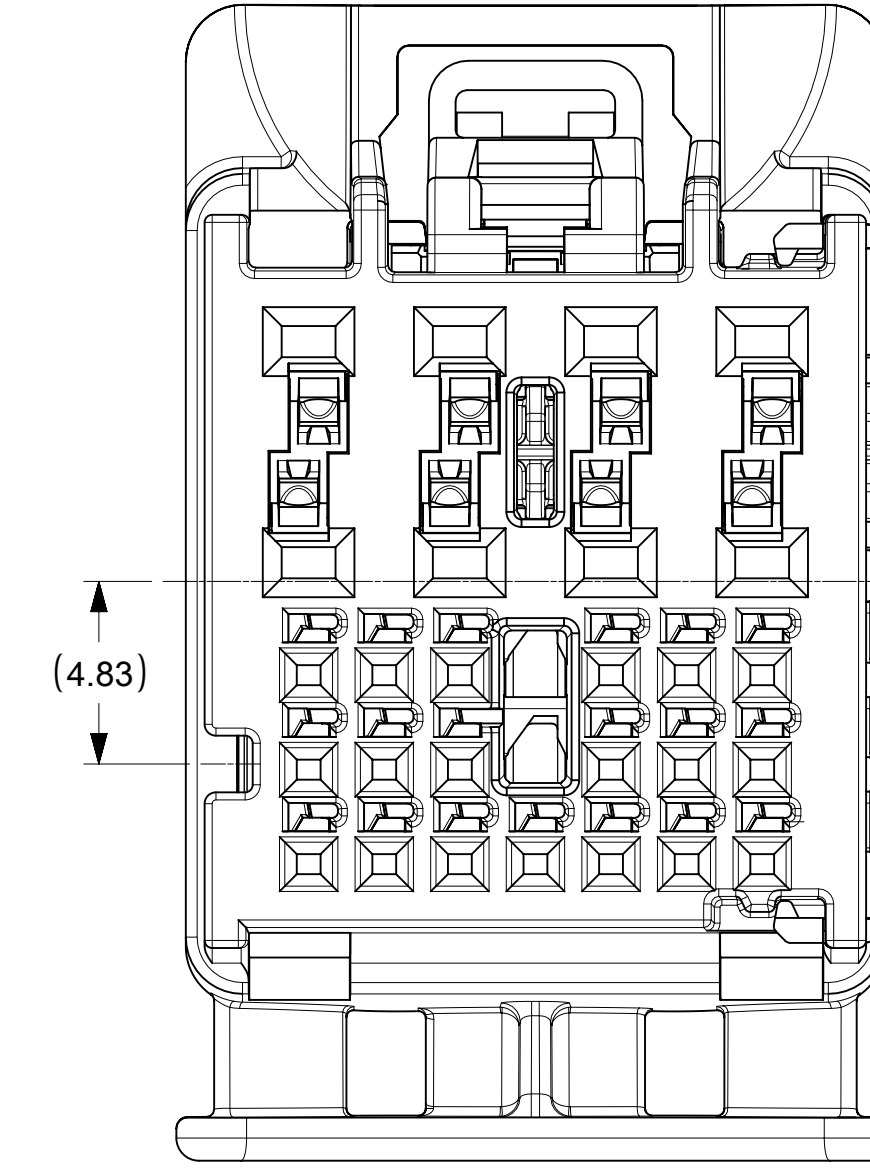

27 WAY CONNECTOR ASSY  
KEY 3  
P/N 1600290013

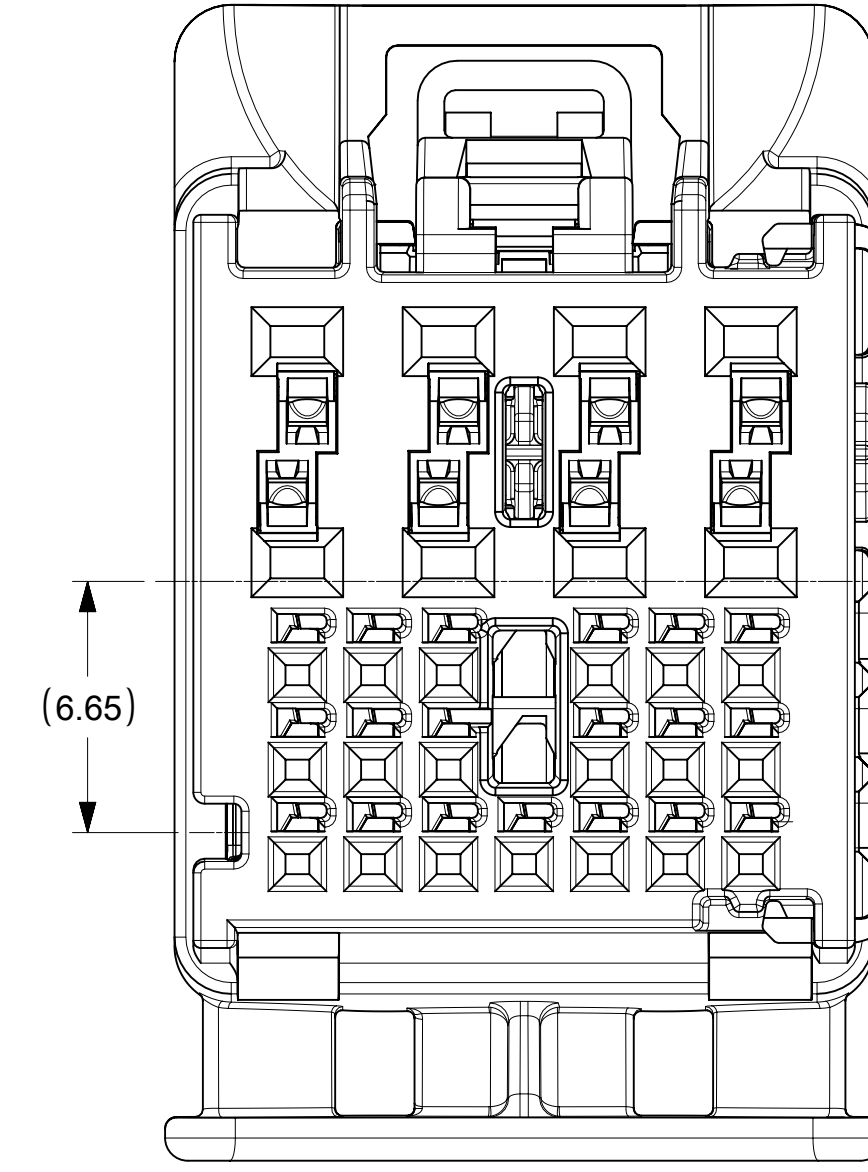

27 WAY CONNECTOR ASSY  
KEY 4  
P/N 1600290014

PART NUMBER	PLATING	SUPPLIER	WIRE GAGE (mm2)	TERMINAL FAMILY	WIRE SPECIFICATION
200096-3101	TIN PLATING	MOLEX	0.35	TAK FAMILY (0.5 mm)	VW 60306 or GMW 15626 (SEE APPLICATION SPECIFICATION FOR MORE DETAILS)
200096-3201	TIN PLATING	MOLEX	0.13	TAK FAMILY (0.5 mm)	
2272196-2	TIN PLATING	TE	0.35	Generation 50 Locking Lance (0.5mm)	SAE/ J1128 THIN WALL INSULATION
2272196-1	TIN PLATING	TE	0.13	Generation 50 Locking Lance (0.5mm)	
35072403	TIN PLATING	DELPHI	0.35 - 0.5	TAXI TERM OCS 1.2	
35072404	TIN PLATING	DELPHI	0.75 - 0.8		
35072405	TIN PLATING	DELPHI	0.8 - 1.0		
35072406	TIN PLATING	DELPHI	1.25 - 1.5		GMW 15626 INSULATION TYPE FLR (REGULAR THIN WALL)
SMSA-A031T-M1.2	TIN PLATING	JST	0.5 - 0.75	MSA 1.2mm TERMINAL	
SMSA-A041T-M1.2	TIN PLATING	JST	1.0 - 1.5	MSA 1.2mm TERMINAL	

NOTES: VALID UNLESS OTHERWISE SPECIFIED

27WAY/28WAY ARE DEPOPULATED VARIANTS OF THE 29WAY

- GENERAL:
  - APPLICATION SPECIFICATION SEE: AS-160014-001
  - PRODUCT SPECIFICATION SEE: PS-160014-001
  - PACKAGING SPECIFICATION PER MOLEX DRAWING: PK-31302-266
  - PARTS MUST BE IN COMPLIANCE TO MOLEX CHEMICAL SUBSTANCES FOR PRODUCTS AND PACKAGING SPECIFICATION: ES-40000-5016
  - DATA MUST BE SUBMITTED UNDER THE MOLEX PART NUMBER TO IMDS (COMPANY ID#13255)
- DESIGN - MATERIALS:
  - SEE BOM TABLE
- DESIGN - GEOMETRY:
  - ALL GRAPHIC DATA IS BASIC (NO TOLERANCE) AND MUST BE TAKEN FROM THE DATA FILE AT ITS LATEST REVISION.
  - PRODUCT DESIGN MODEL NUMBER(S): SEE BOM TABLE
  - GEOMETRIC DIMENSIONS AND TOLERANCES PER ASME Y14.5-2009
  - EDGES AND UNDIMENSIONED DETAILS PER ISO13715
  - CORNERS SHOWN AS SHARP TO BE R 0.2 MAX.
  - MARKED TEXT TO INCLUDE RECYCLING CODE, CAVITY ID, VENDOR IDENTIFICATION, AND CUSTOMER MATERIAL NUMBER.
    - LASER ETCHED DATE CODE
      - 1ST THROUGH 2ND DIGIT = CALENDAR YEAR
      - 3RD THROUGH 5TH DIGIT = "DAY #" OF YEAR
      - 6TH THROUGH 7TH DIGIT = HOUR OF DAY
      - 8TH THROUGH 9TH DIGIT = MINUTE OF HOUR
      - 10TH THROUGH 11TH DIGIT = SECOND OF MINUTE
- DESIGN - MANUFACTURING:
  - VISUAL DEFECTS SHALL MEET COSMETIC STANDARD PS-45499-002 (Class B)

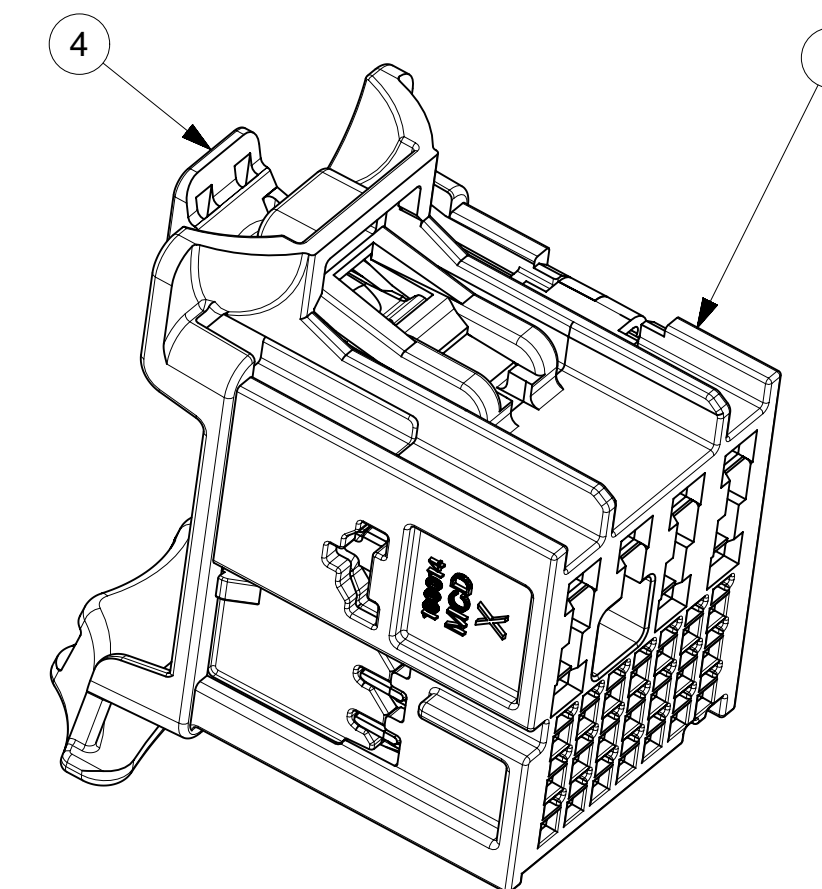

SCALE 3:1

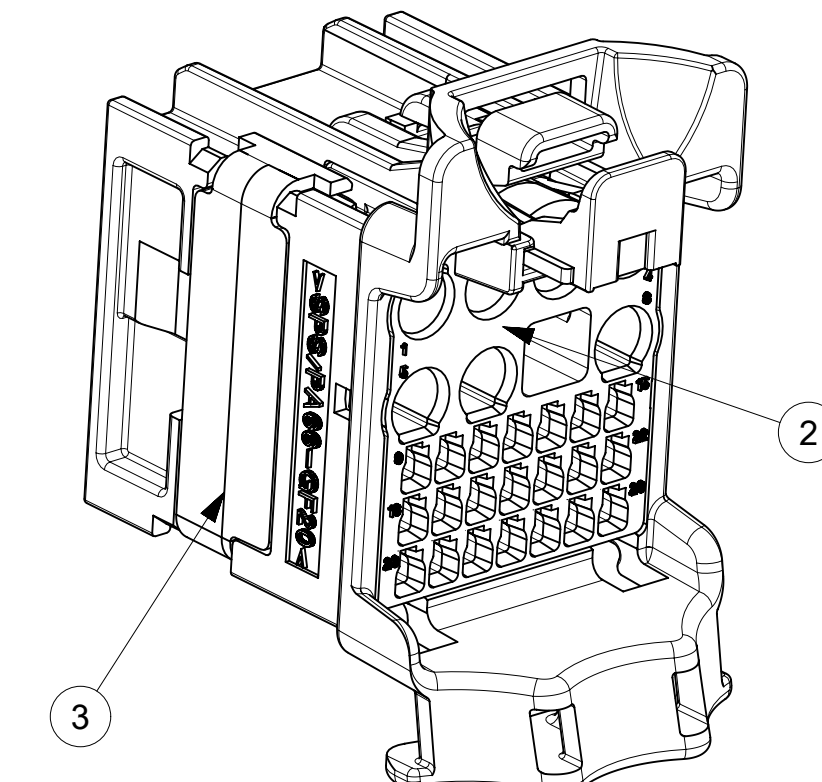

SCALE 3:1

INSPECTION BALLOON NUMBER LOG
PER DRAWING REVISION : A6
LAST BALLOON NUMBER: 2
ADDED BALLOON NUMBER: NONE
DELETED BALLOON NUMBER: NONE

A6	UPDATED TAK50 TERMINAL PNS 21-July-2021 YPENG47 ECN 648438
A5	UPDATED DELPHI 1.2 TERMINAL PNS 10-Apr-2020 YPENG47 ECN 635661
A4	UPDATED ISL TO PRE-LOCK(SHIPMENT) STATUS 31-Mar-2020 YPENG47 ECN 635045
REVISION	DESCRIPTION

MOLEX ASSEMBLY PART NO.'S	CIRCUIT COUNT	KEY	OUTER SHROUD COLOR	COMPONENTS						
				ITEM 1				ITEM 2	ITEM 3	ITEM 4
				OUTER SHROUD KEY 1	OUTER SHROUD KEY 2	OUTER SHROUD KEY 3	OUTER SHROUD KEY 4	INNER HOUSING	ISL	CPA
1600140011	28	1	DARK GRAY	SPS/PA66-GF20 1600140511	SPS/PA66-GF20 1600140512	SPS/PA66-GF20 1600140513	SPS/PA66-GF20 1600140514	SPS/PA66-GF20 1600140701	SPS-GF30 1600140601	PA66-GF50 1600140703
1600140012	28	2	LT GREEN A	1	1			STONE GRAY	1	1
1600140013	28	3	LT GRAY			1		STONE GRAY	1	1
1600140014	28	4	BLACK				1	STONE GRAY	1	1
1600290011	27	1	BLACK	1600290511	1600290512	1600290513	1600290514	1600290701	1600290601	1600140703
1600290012	27	2	LT GREEN B	1	1			DARK GRAY	1	1
1600290013	27	3	LT BLUE B			1		DARK GRAY	1	1
1600290014	27	4	PURPLE C				1	DARK GRAY	1	1

FUNCTIONAL SYMBOLS	THIS DRAWING CONTAINS INFORMATION THAT IS PROPRIETARY TO MOLEX ELECTRONIC TECHNOLOGIES, LLC AND SHOULD NOT BE USED WITHOUT WRITTEN PERMISSION	DIMENSION UNITS	SCALE	CURRENT REV DESC: UPDATED TAK50 TERMINAL PNS
	mm	5:1		
DIVISIONAL SYMBOLS	GENERAL TOLERANCES (UNLESS SPECIFIED)	4 PLACES	±	EC NO: 648438
	ANGULAR TOL	± 3.0°		DRWN: YPENG47 2021/07/21
	3 PLACES	±		CHK'D: RCARLSON 2021/07/29
	2 PLACES	± 0.3		APPR: JCONDON 2021/08/02
	1 PLACE	± 0.3		INITIAL REVISION:
	0 PLACES	± 0.3		DRWN: RCARLSON 2019/02/14
	DRAFT WHERE APPLICABLE MUST REMAIN WITHIN DIMENSIONS			APPR: JCONDON 2019/02/25
	THIRD ANGLE PROJECTION	DRAWING	SERIES	
		D-SIZE	160014	
DOCUMENT NUMBER		DOC TYPE		DOC PART
1600140011		PSD		000
MATERIAL NUMBER		CUSTOMER		REVISION
		GENERAL MARKET		A6
SHEET NUMBER			1 OF 2	

NOTE: 28 WAY CONNECTOR VARIANT SHOWN.  
DIMENSIONS APPLY TO ALL CONNECTOR VARIANTS OF 29 WAY

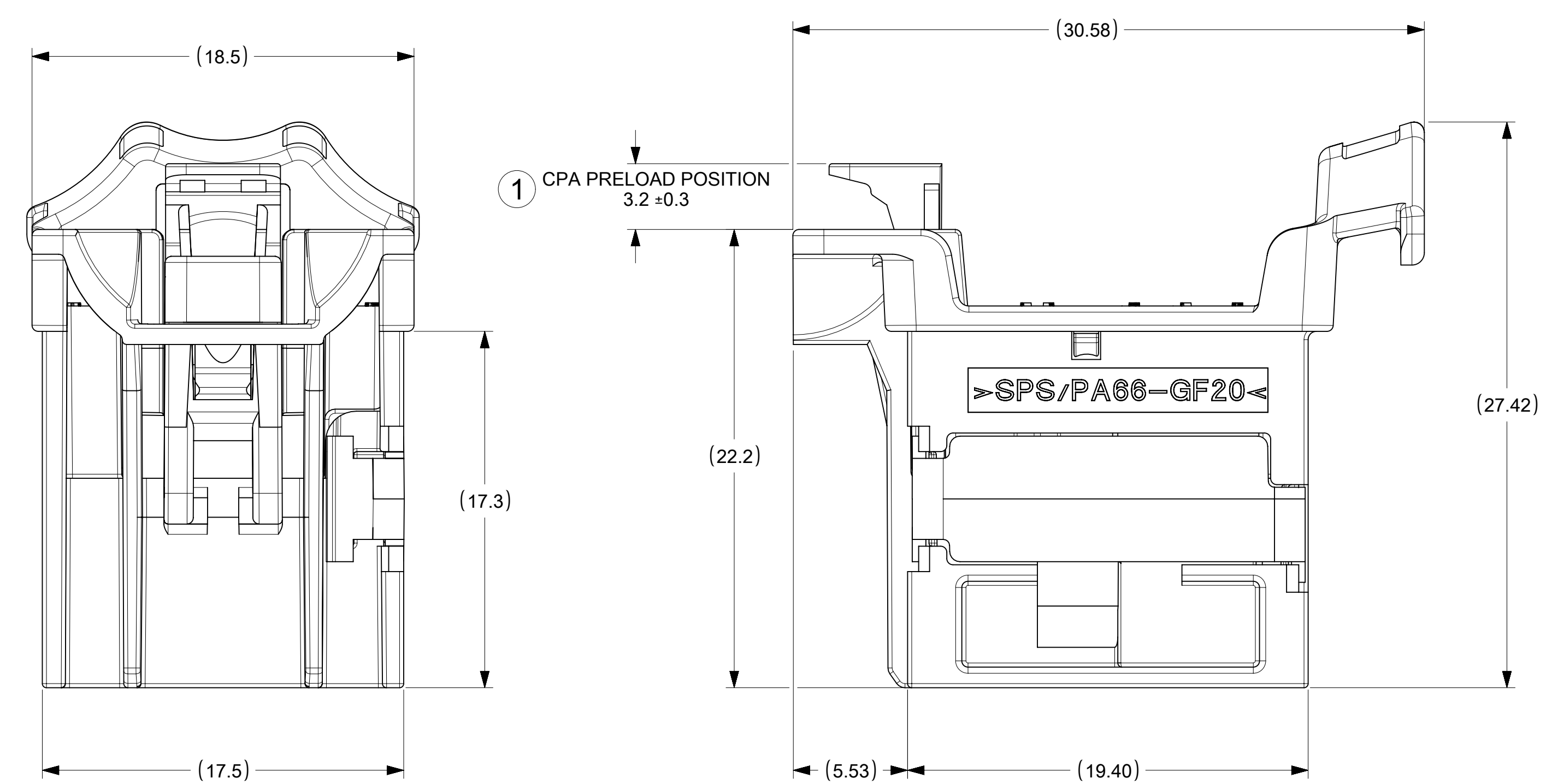
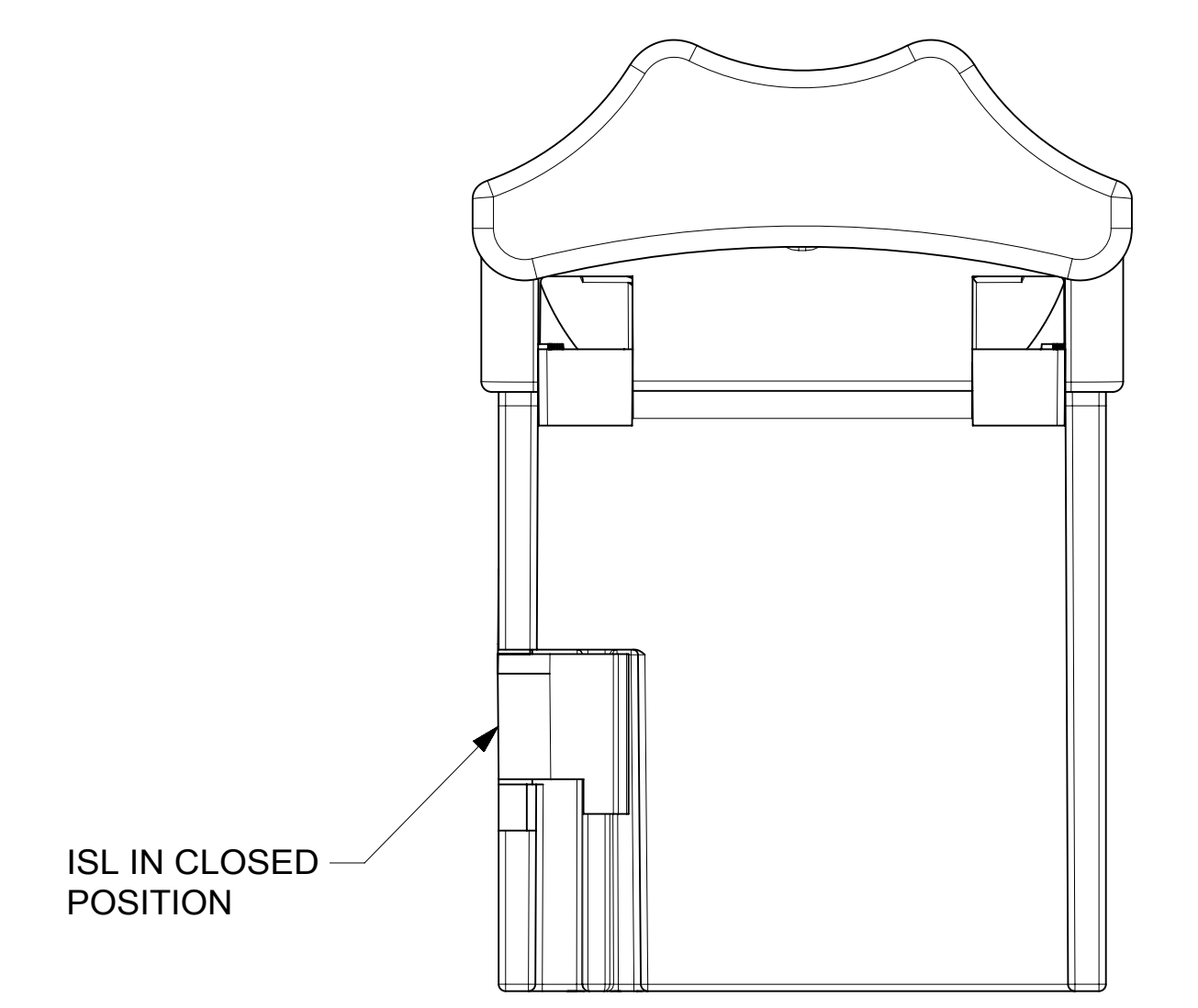
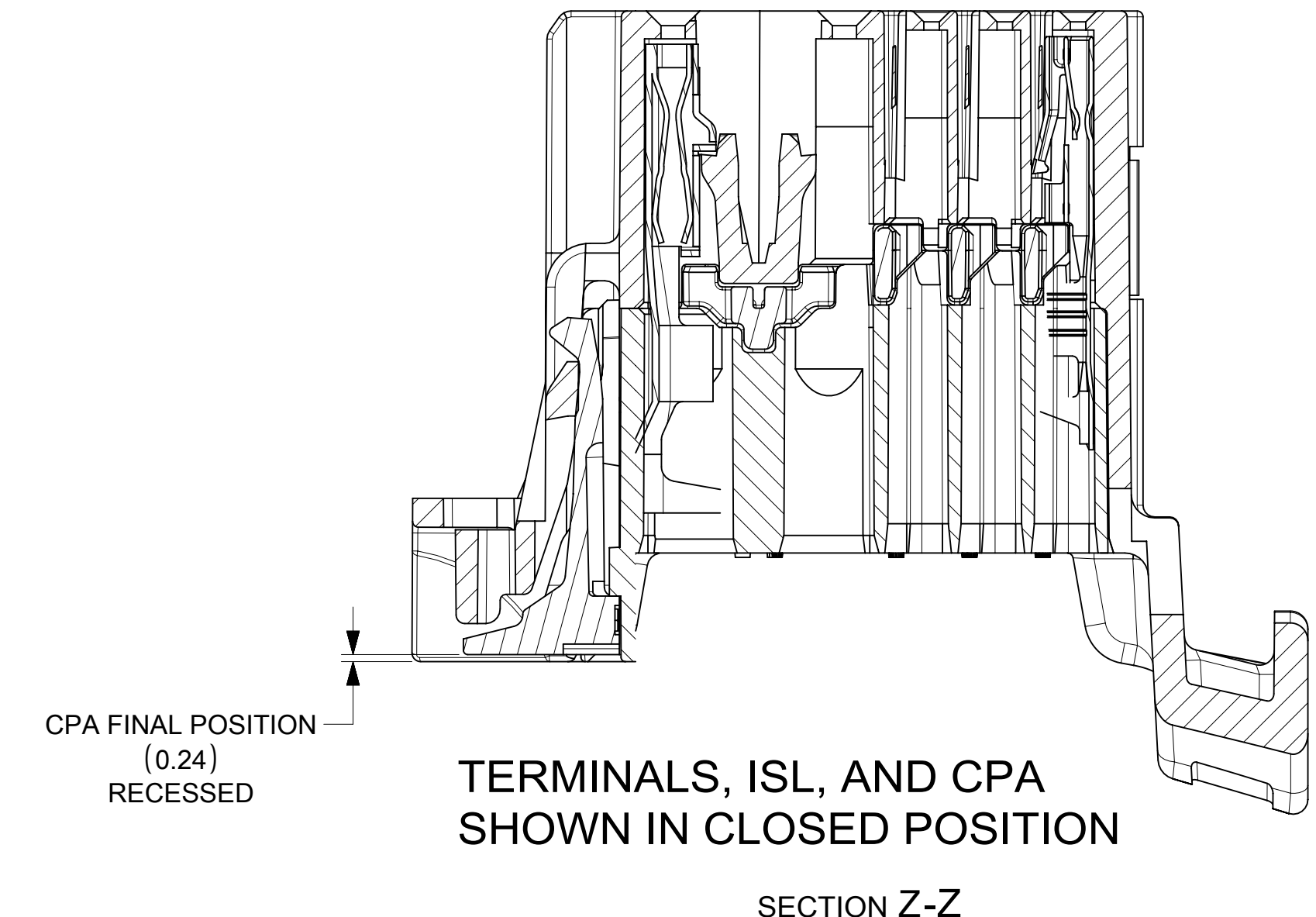
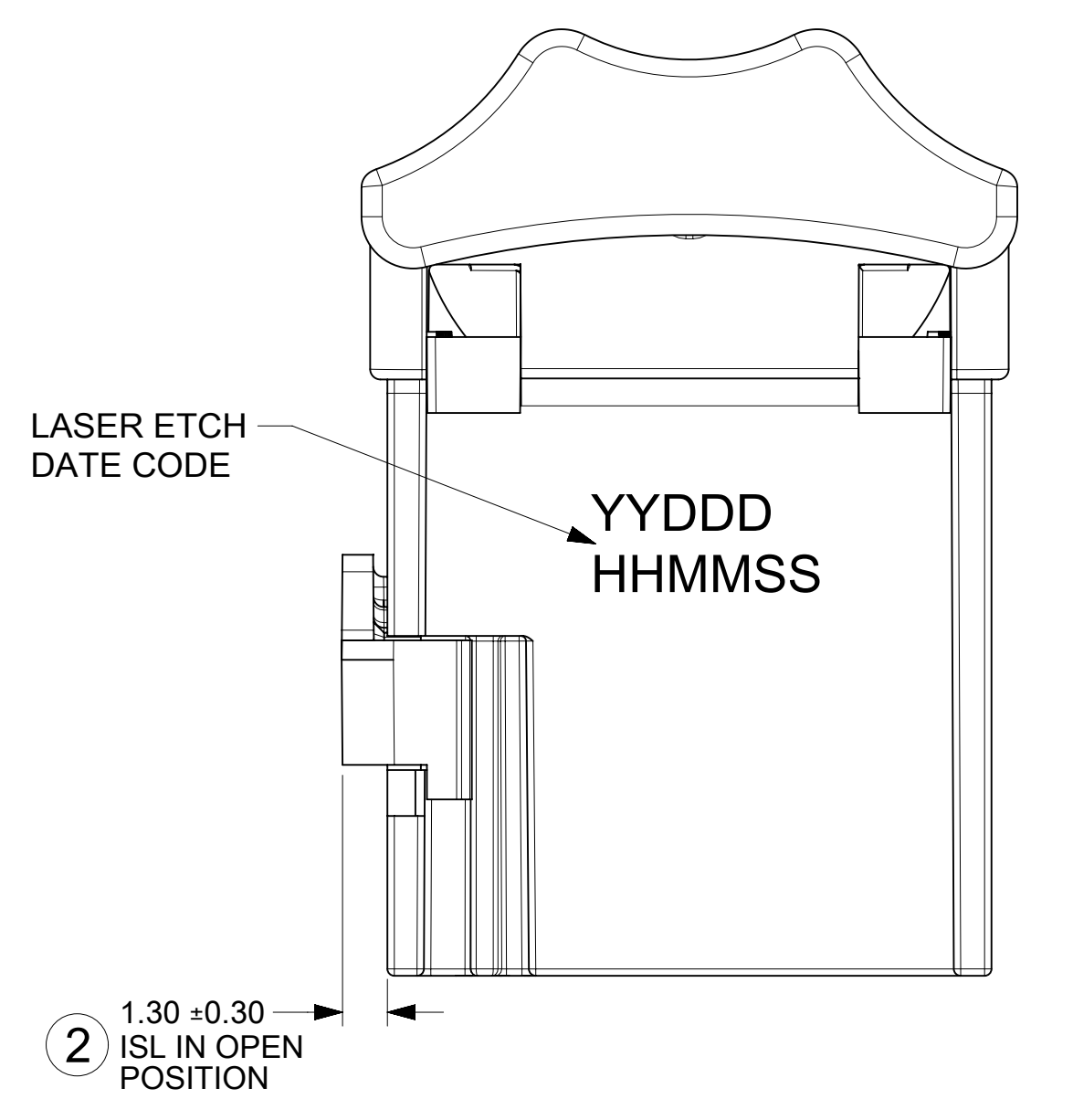
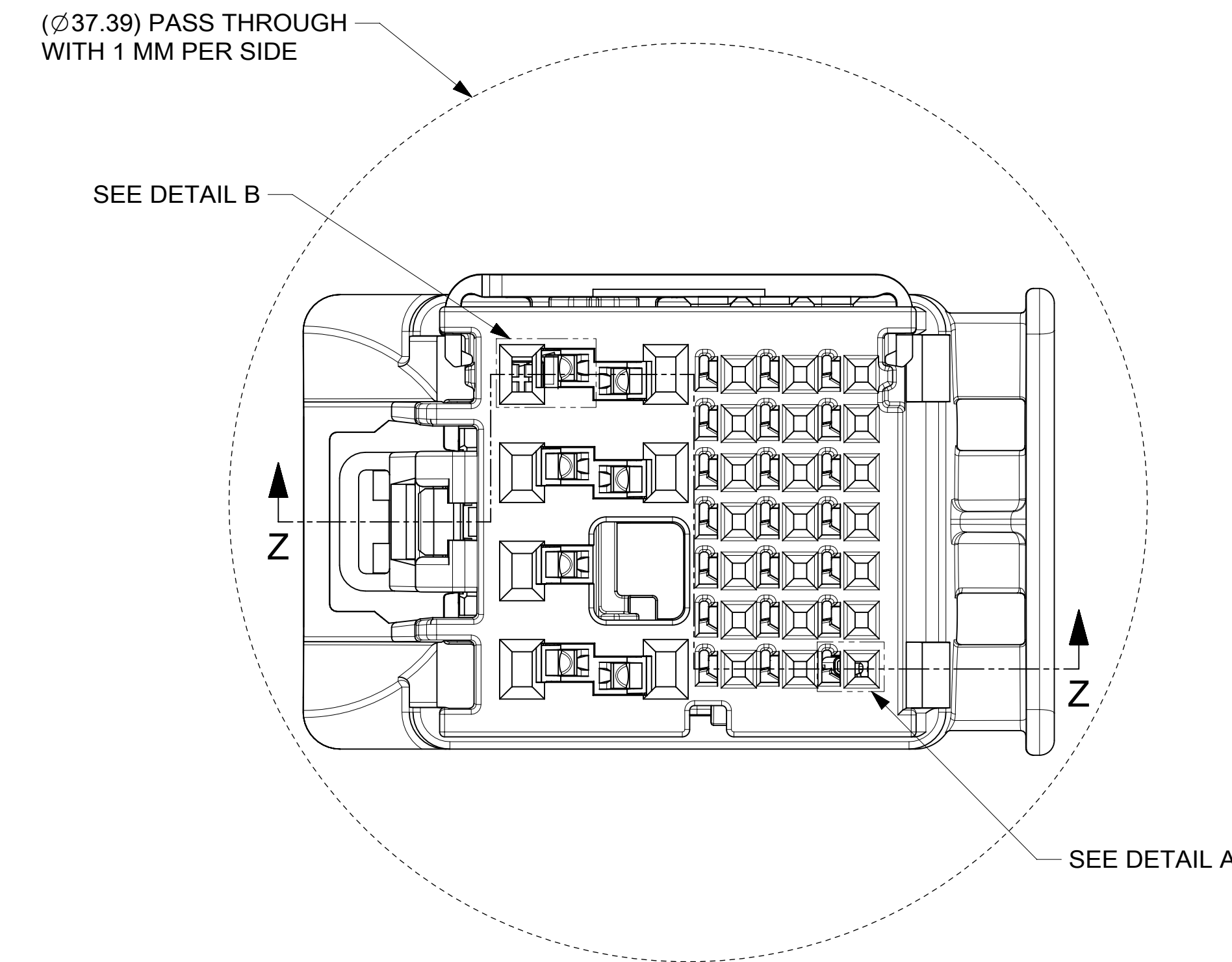
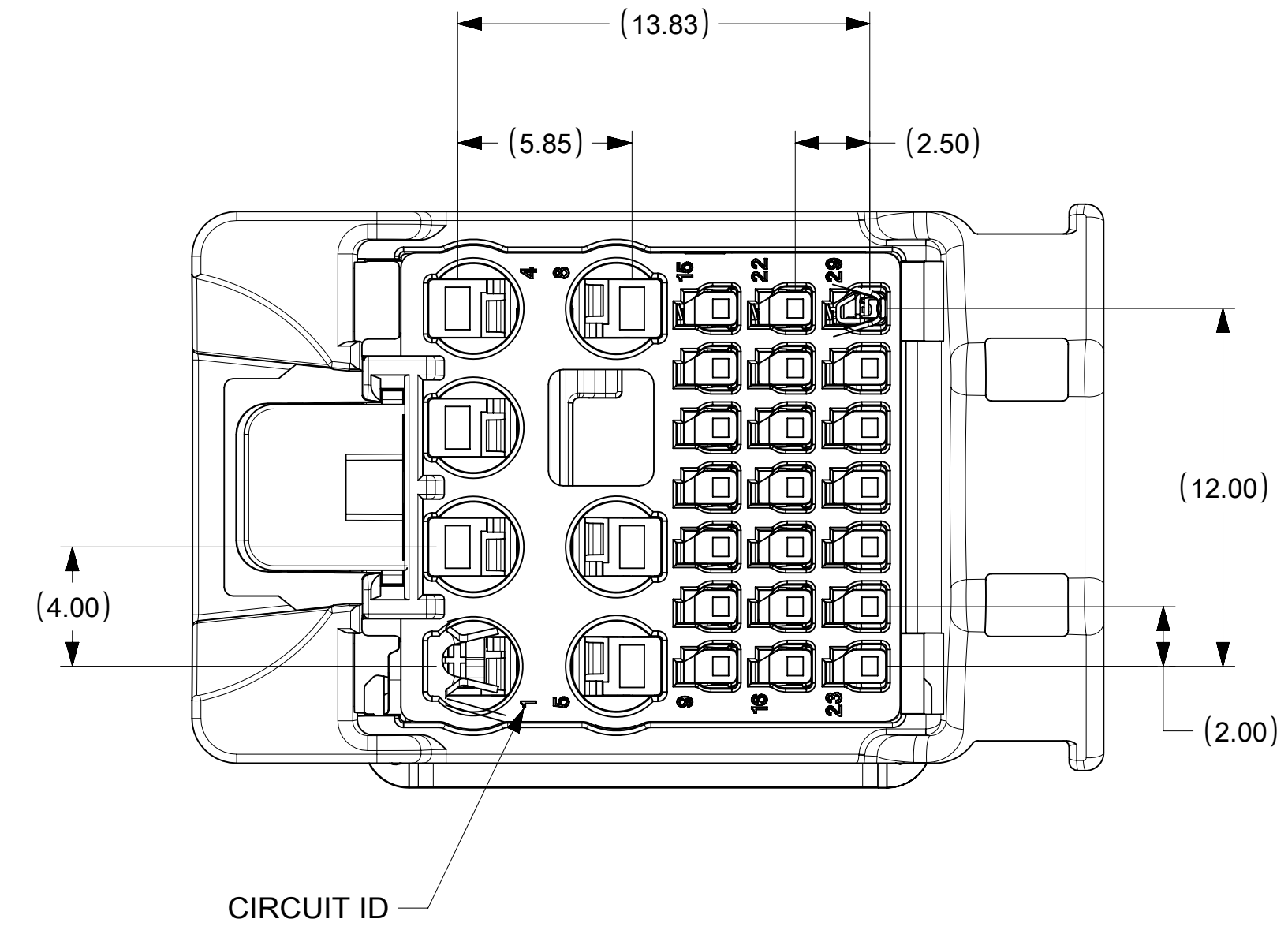
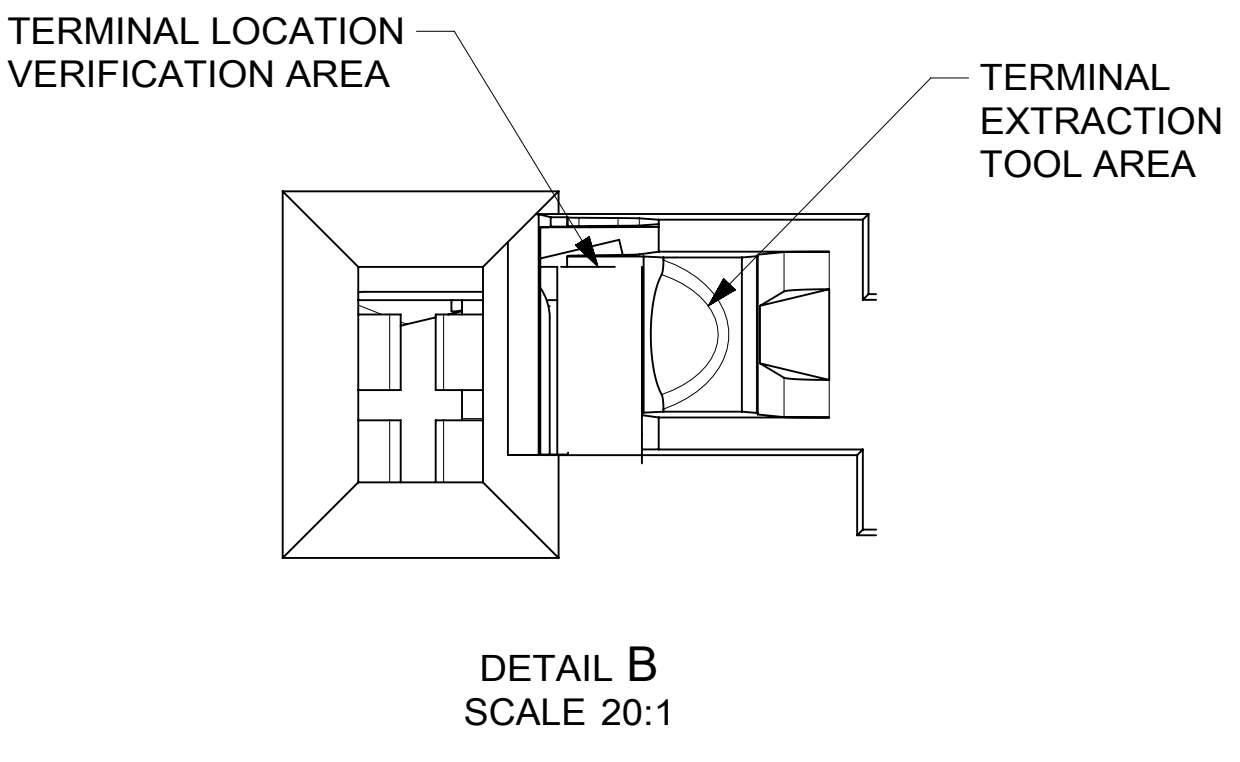
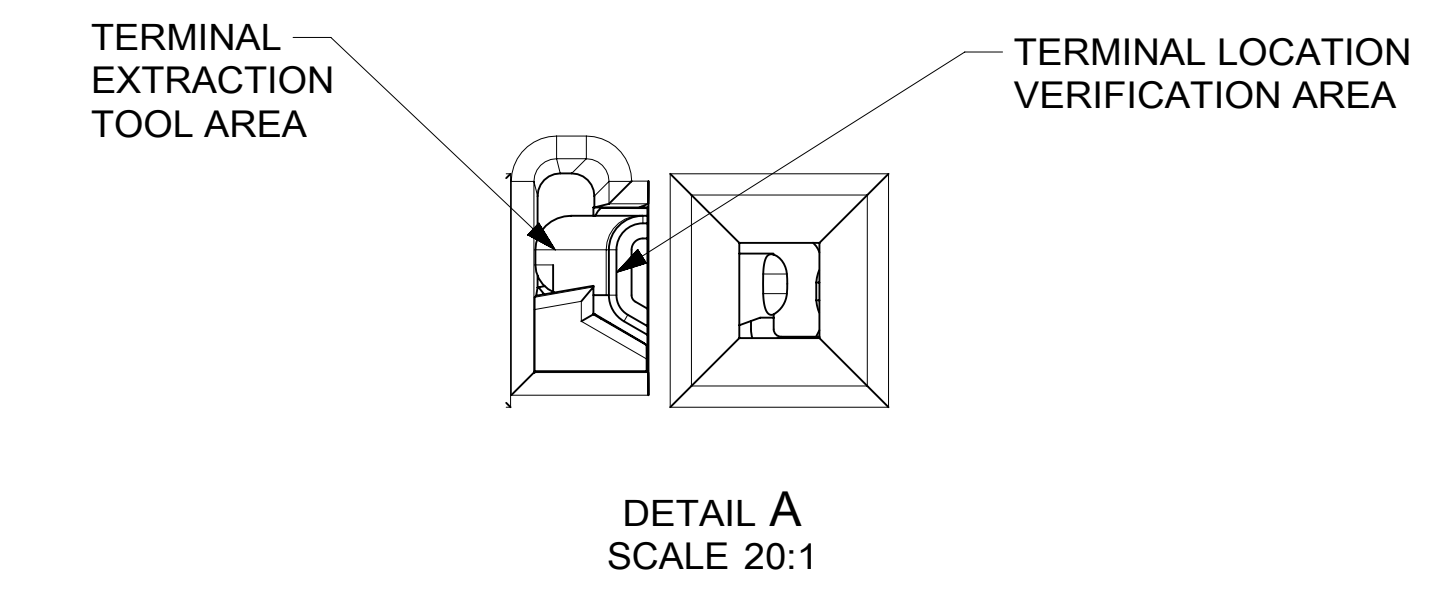

FUNCTIONAL SYMBOLS	THIS DRAWING CONTAINS INFORMATION THAT IS PROPRIETARY TO MOLEX ELECTRONIC TECHNOLOGIES, LLC AND SHOULD NOT BE USED WITHOUT WRITTEN PERMISSION		
	DIMENSION UNITS	SCALE	CURRENT REV DESC: UPDATED TAK50 TERMINAL PMS
$F_A = 0$	mm	5:1	
$F_E = 0$	GENERAL TOLERANCES (UNLESS SPECIFIED)		
$F_P = 0$	ANGULAR TOL $\pm 3.0^\circ$		
DIVISIONAL SYMBOLS	4 PLACES	$\pm$	EC NO: 648438
	3 PLACES	$\pm$	DRWN: YPENG47 2021/07/21
	2 PLACES	$\pm 0.3$	CHK'D: RCARLSON 2021/07/29
	1 PLACE	$\pm 0.3$	APPR: JCONDON 2021/08/02
	0 PLACES	$\pm 0.3$	INITIAL REVISION:
DRAFT WHERE APPLICABLE MUST REMAIN WITHIN DIMENSIONS		THIRD ANGLE PROJECTION	DRWN: RCARLSON 2019/02/14
		DRAWING	APPR: JCONDON 2019/02/25
		SERIES	160014
DOCUMENT STATUS		P1	RELEASE DATE
2021/08/02		13:46:01	
1600140011		PSD	000 A6
GENERAL MARKET		SHEET NUMBER	
		2 OF 2	

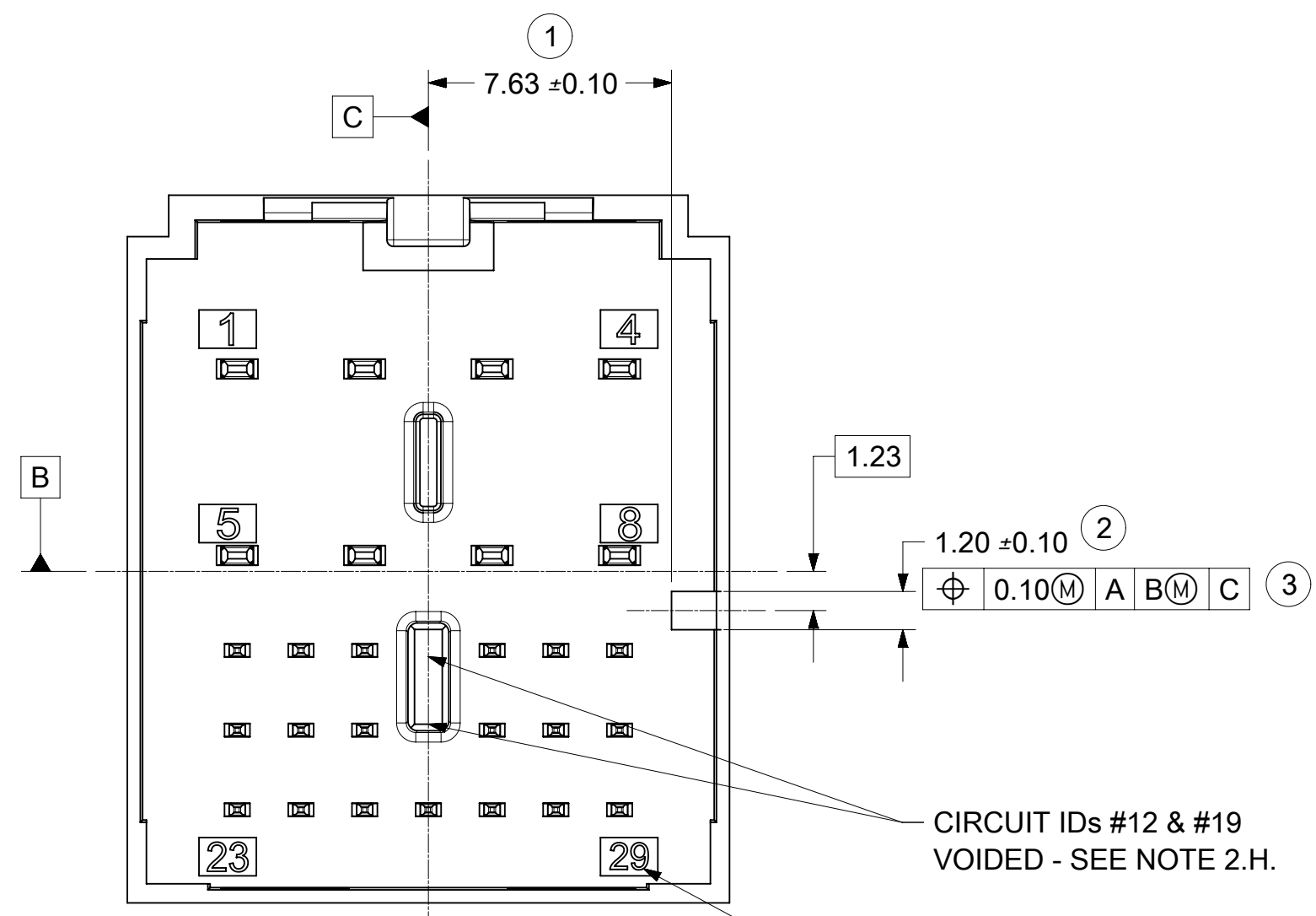

INTERFACE KEY #1  
MATING CONNECTOR COLOR: BLACK

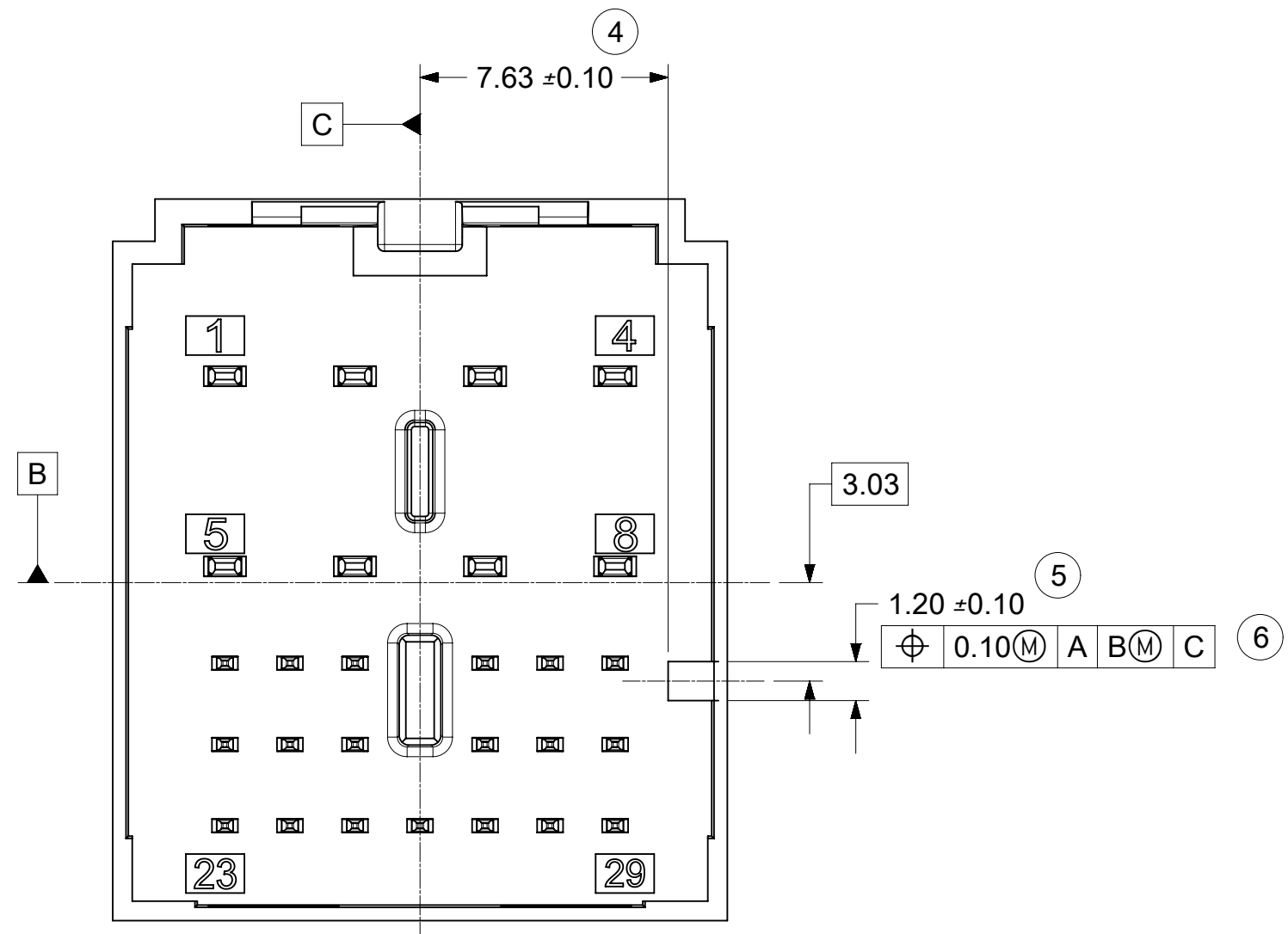

INTERFACE KEY #2  
MATING CONNECTOR COLOR: LT GREEN B

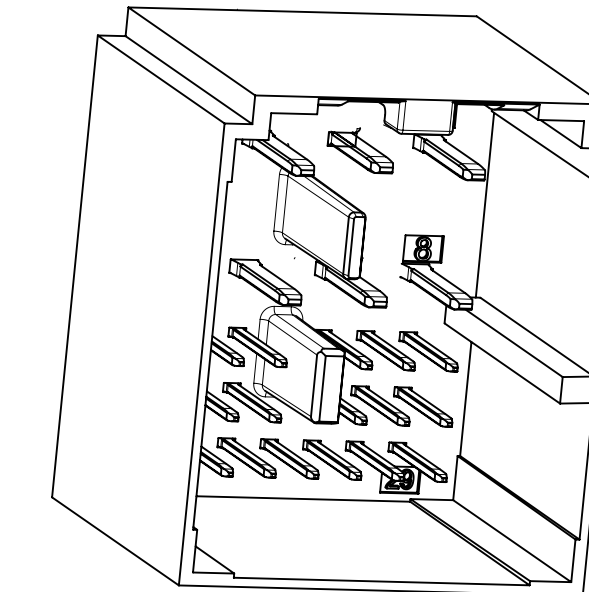
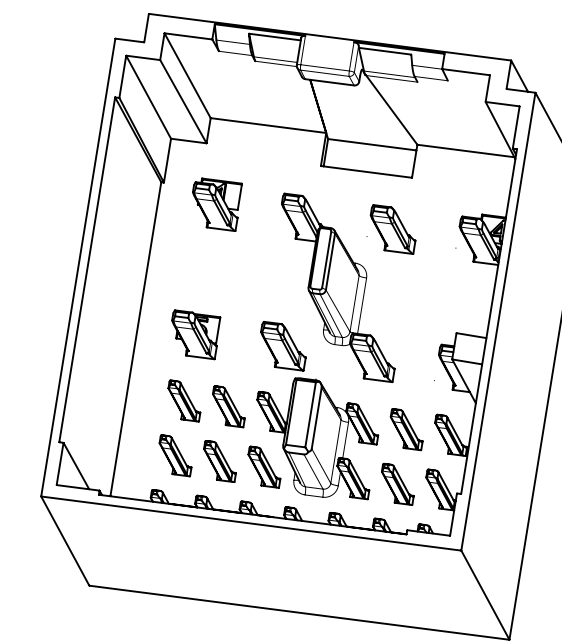

NOTES: VALID UNLESS OTHERWISE SPECIFIED

- DESIGN - MATERIALS:
  - RESIN MATERIAL: PBT+GF30 OR SPS+GF30 OR EQUIVALENT
  - PIN/BLADE MATERIAL: ACCORDING TO USCAR DRAWING EWCAP-001 NOTE B2.
  - PLATING: ACCORDING TO USCAR DRAWING EWCAP-001 TIN REFLOW WITH UNDERPLATE.
  - PIN TIPS ACCORDING TO USCAR DRAWING EWCAP-001 (120-T002 AND 050-T001)
  - DEVIATION TO EWCAP-001 ACCEPTABLE IF PERFORMANCE(ELECTRICAL/MECHANICAL)IS SHOWN TO BE EQUAL OR BETTER AS REQUIRED BY VALIDATION TESTING.
- DESIGN - GEOMETRY:
  - ALL GRAPHIC DATA IS BASIC (NO TOLERANCE) AND MUST BE TAKEN FROM THE DATA FILE AT ITS LATEST REVISION.
  - PRODUCT DESIGN MODEL NUMBER(S): SEE BOM TABLE
  - GEOMETRIC DIMENSIONS AND TOLERANCES PER ASME Y14.5M-2009
  - GENERAL TOLERANCES:
    - LINEAR: PER DIN 16901 LINEAR CODE B FOR PRECISION ENGINEERING
    - ANGULAR: ± 3°
  - EDGES AND UNDIMENSIONED DETAILS PER ISO13715
  - CORNERS SHOWN AS SHARP TO BE R 0.2 MAX.
  - LETTERING SHALL BE 0.15 MAX RAISED IN 0.25 MAX RECESS PAD. THIS INCLUDES RECYCLING CODE, CAVITY ID, VENDOR IDENTIFICATION, AND CUSTOMER MATERIAL NUMBER. (for small parts: LETTERING SHALL BE 0.10 MAX RAISED IN 0.15 MAX RECESS PAD)
  - CIRCUIT LOCATIONS 12 AND 19 VOIDED FOR 27WAY INTERFACE
- DESIGN - MANUFACTURING:
  - DRAFT TO BE WITHIN TOLERANCE.

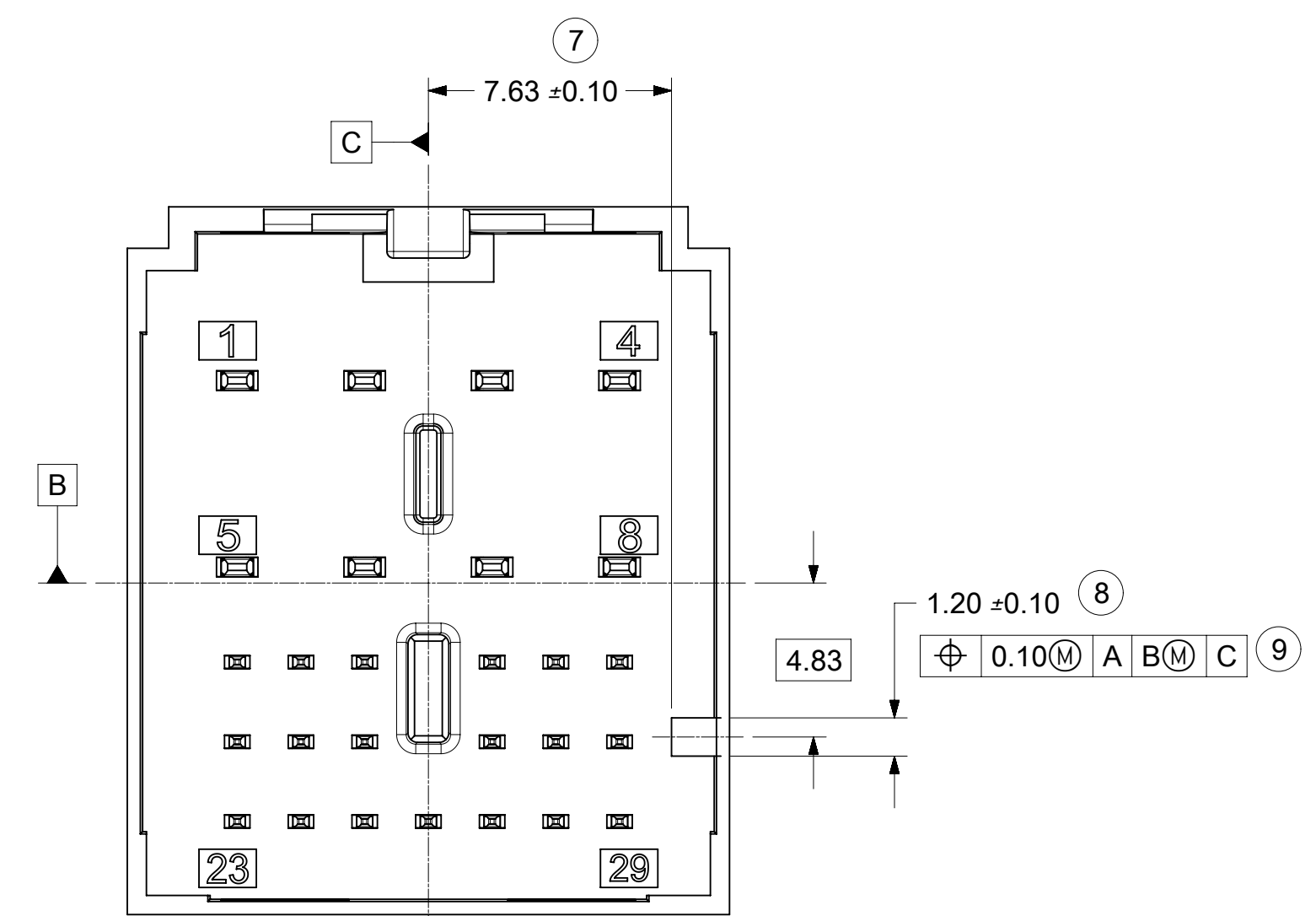

INTERFACE KEY #3  
MATING CONNECTOR COLOR: LT BLUE B

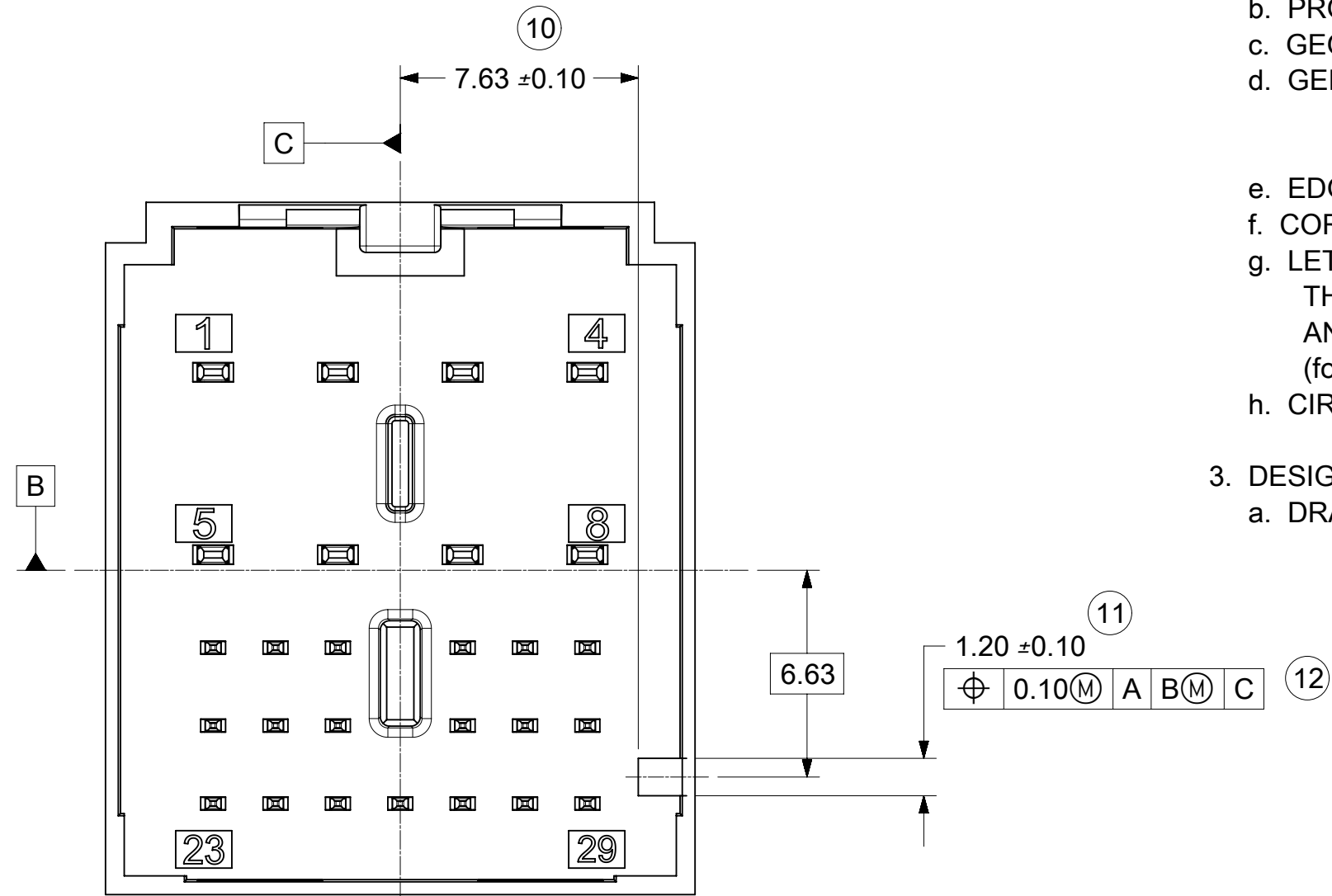

INTERFACE KEY #4  
MATING CONNECTOR COLOR: PURPLE C

B1	ADDED BALLOONS JCONDON 08/02/2018
B	REMOVED 0.2MM FROM CONNECTOR LOCK TAB FEATURE
A1	NOTE 1.E. ADDED JCONDON 11/13/2017
A	NX-REMASTERING SAP # 10867412
9	UAU2016-1182 SAP # 10762453 JCONDON 02/08/2016
8	UAU2016-0542 SAP # 10728331 JCONDON 10/20/2015
7	UAU2015-1446 SAP # 10681629 JCONDON 03/25/2015
6	UAU2015-1212 SAP # 10674908 JCONDON 02/06/2015
5	UAU2015-1036 SAP # 10670355 JCONDON 01/07/2015
4	UAU2015-0634 SAP # 10661788 JCONDON 10/22/2014
3	UAU2014-1679 SAP # XXXXXXXX JCONDON 03/17/2014
2	UAU2014-1221 SAP # XXXXXXXX MYOUNG01 01/31/2014
1	UAU2014-0715 SAP # XXXXXXXX DAHALL 11/20/2013
REV	DESCRIPTION

SYMBOLS	THIS DRAWING CONTAINS INFORMATION THAT IS PROPRIETARY TO MOLEX ELECTRONIC TECHNOLOGIES, LLC AND SHOULD NOT BE USED WITHOUT WRITTEN PERMISSION		CURRENT REV DESC: ADDED DIMENSION BALLOONS	
	DIMENSION UNITS	SCALE		
▽ = 0	mm	5:1	DRWN: JCONDON 2018/08/02	27WAY STAK50H INTERFACE DRAWING  PRODUCT CUSTOMER DRAWING
▽ = 0	GENERAL TOLERANCES (UNLESS SPECIFIED)		CHK'D: JCONDON 2018/08/03	
▽ = 0	ANGULAR TOL ± °		APPR: MVANSLAMBROU 2018/08/03	DOCUMENT NUMBER
▽ = 0	4 PLACES ±		INITIAL REVISION:	DOC TYPE
▽ = 0	3 PLACES ±		DRWN: DAHALL 2013/11/20	DOC PART
▽ = 0	2 PLACES ±		APPR: KDEKOSKI 2014/01/02	REVISION
▽ = 0	1 PLACE ±		DRWN: DAHALL 2013/11/20	SD-160029-002
▽ = 0	0 PLACES ±		APPR: KDEKOSKI 2014/01/02	
▽ = 0	DRAFT WHERE APPLICABLE MUST REMAIN WITHIN DIMENSIONS		THIRD ANGLE PROJECTION	001
▽ = 0			DRAWING	B1
▽ = 0			SERIES	REVISION
▽ = 0			D-SIZE	160029
			MATERIAL NUMBER	CUSTOMER
			GENERAL MARKET	SHEET NUMBER
				1 OF 3

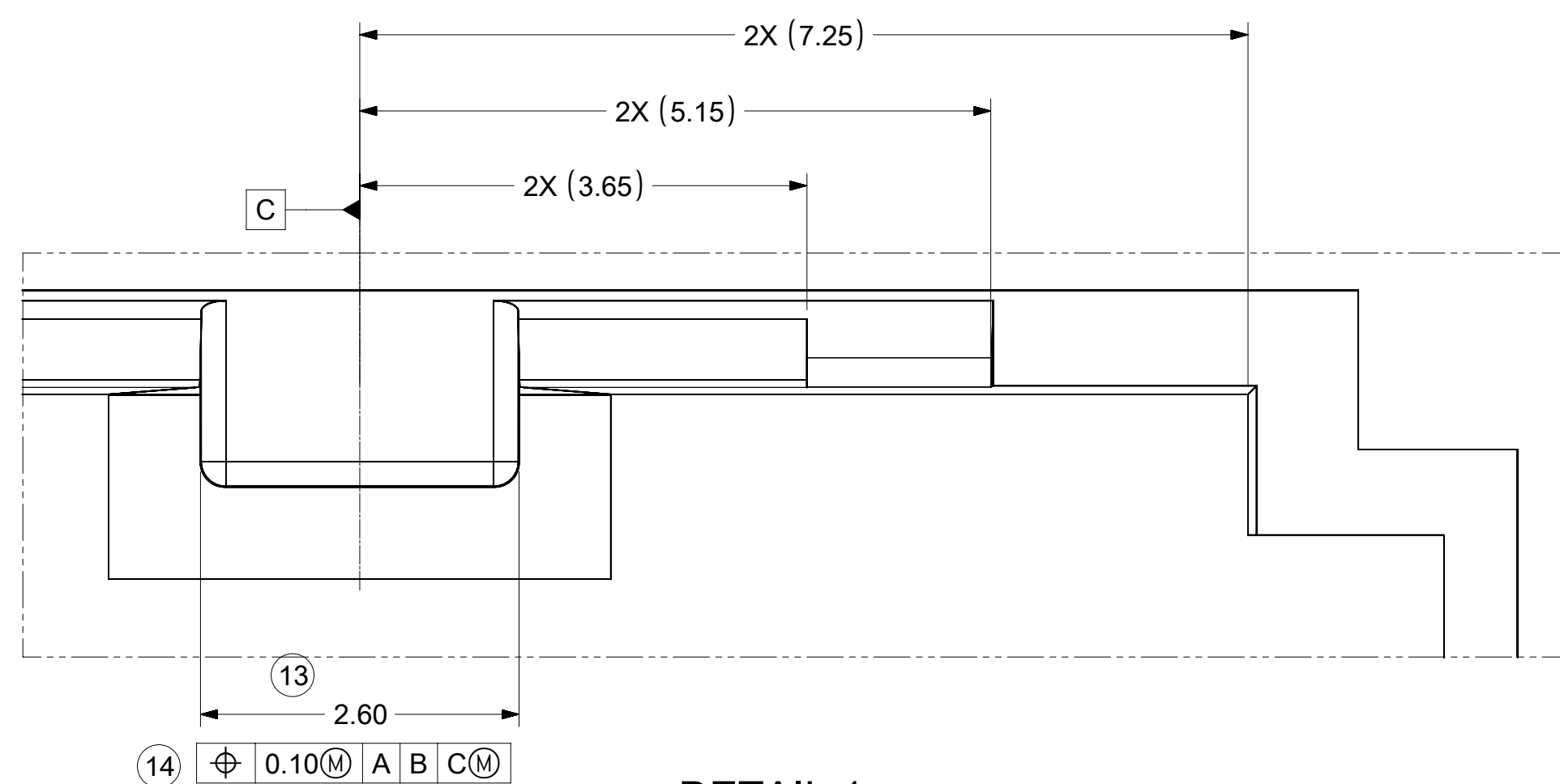

DETAIL 1  
SCALE 20:1

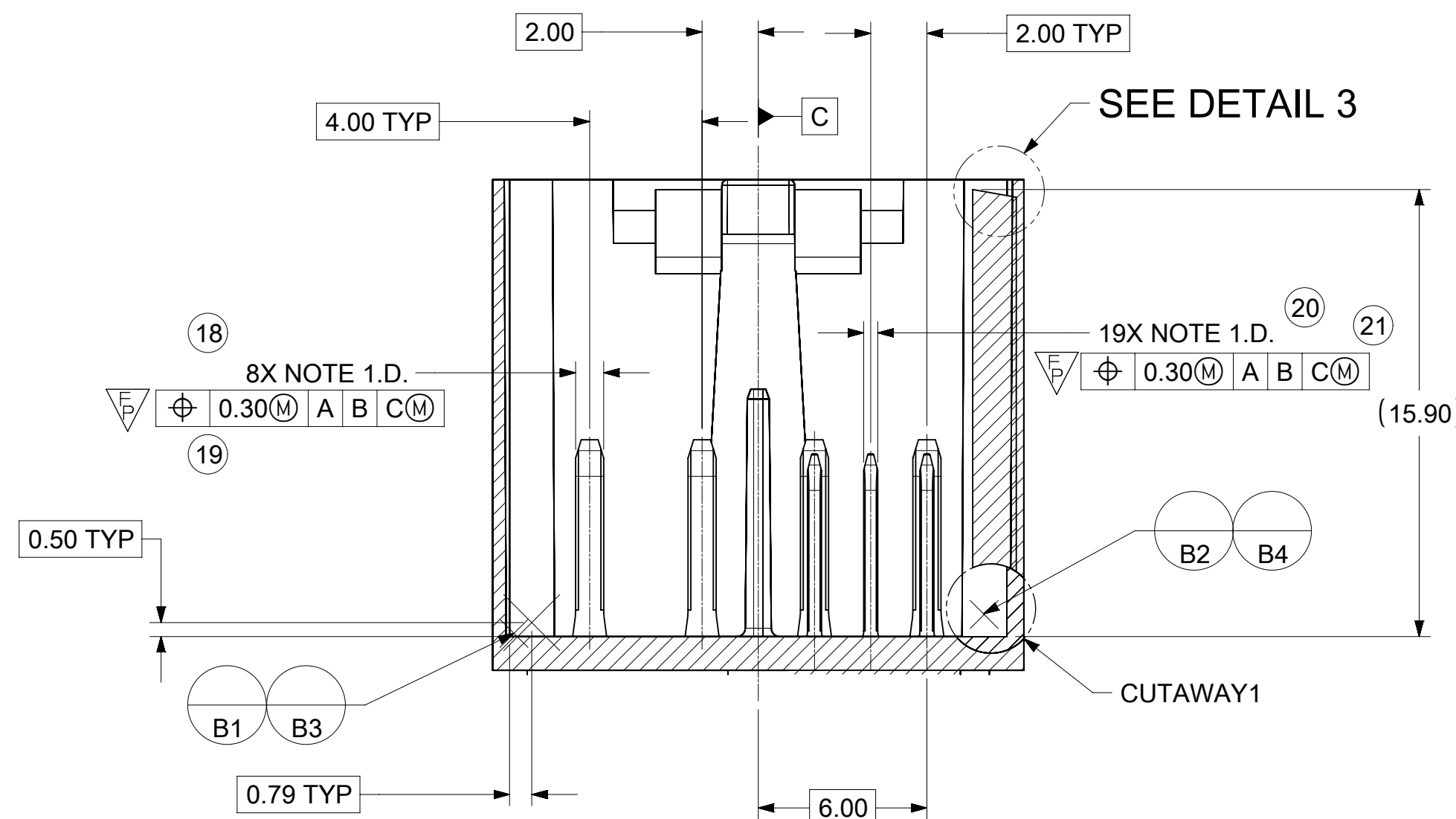

SECTION X-X

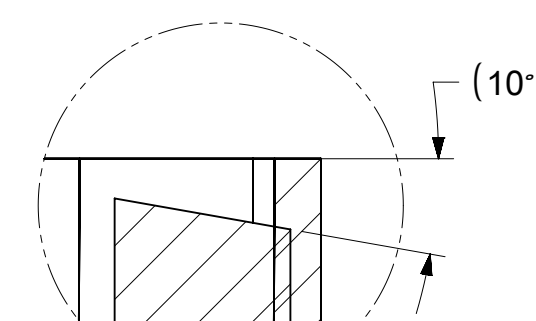

DETAIL 3  
SCALE 15:1

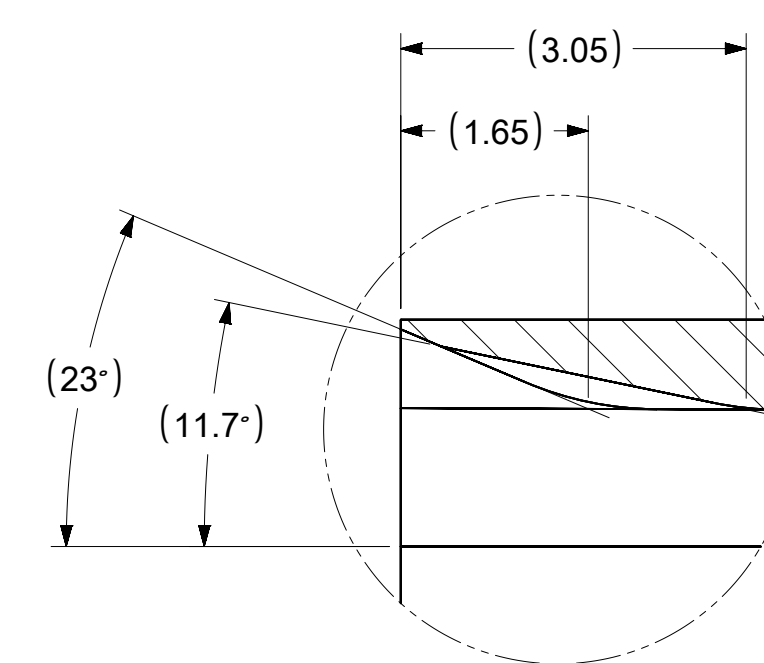

DETAIL 2  
SCALE 15:1

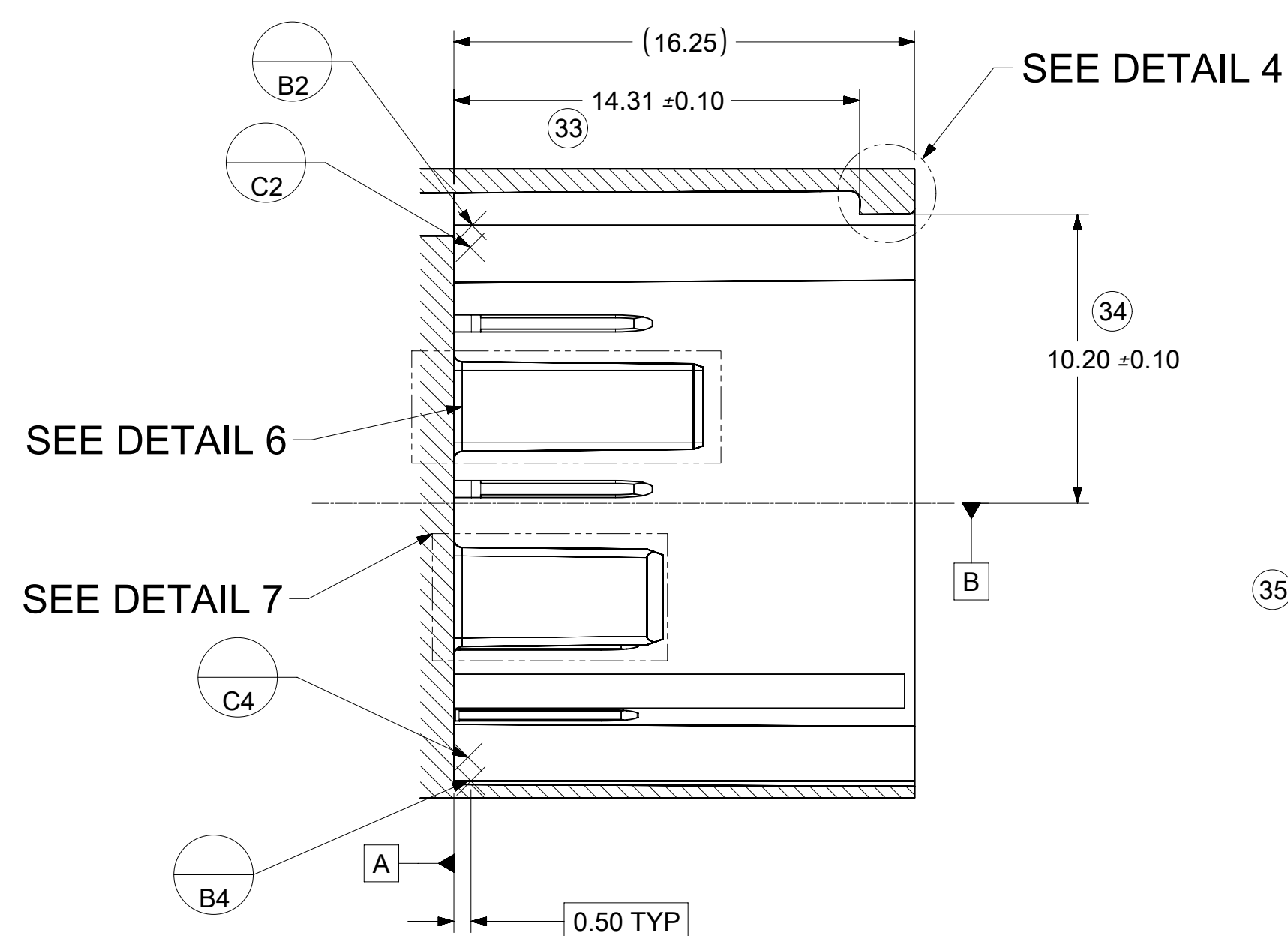

SECTION Y-Y

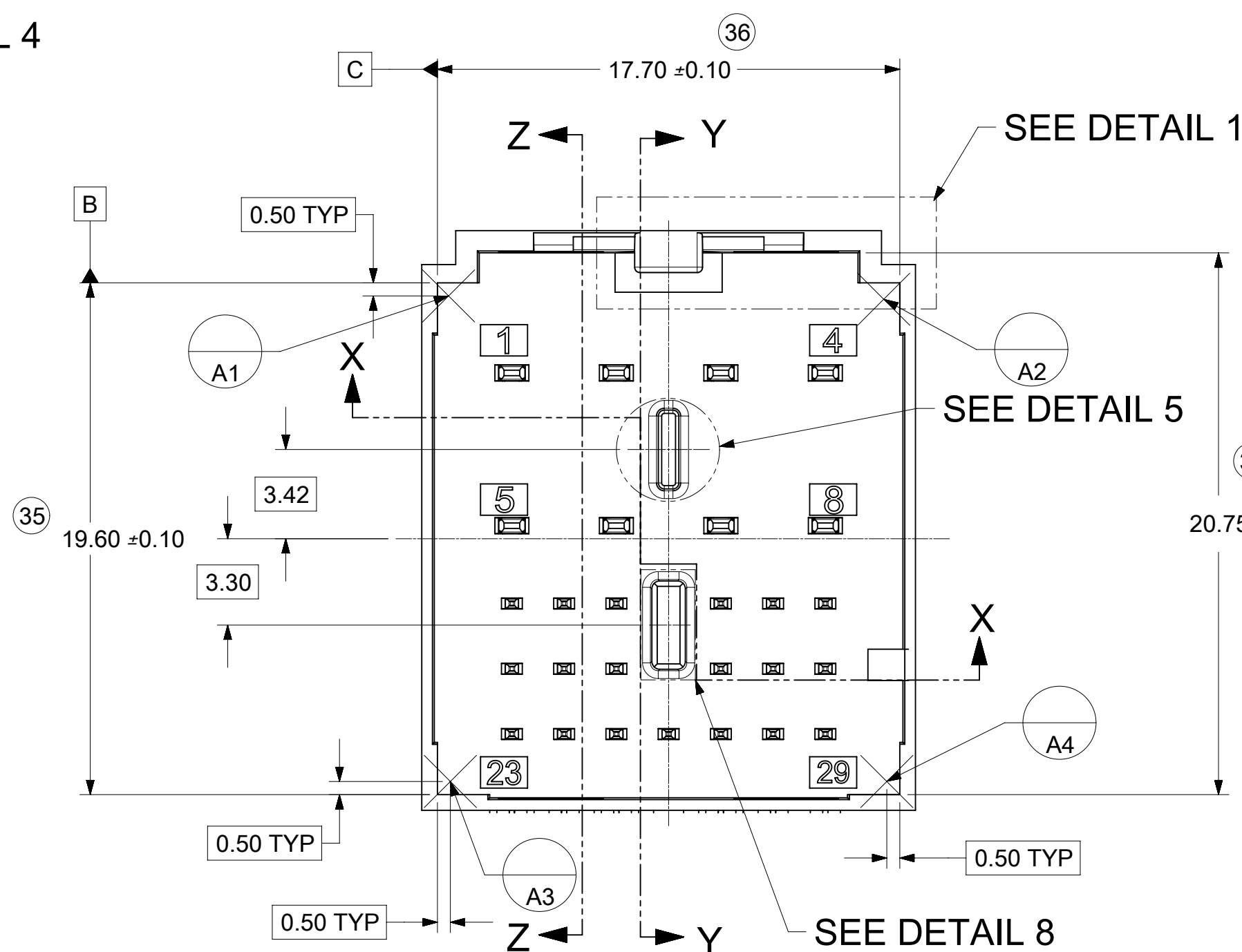

SECTION Z-Z

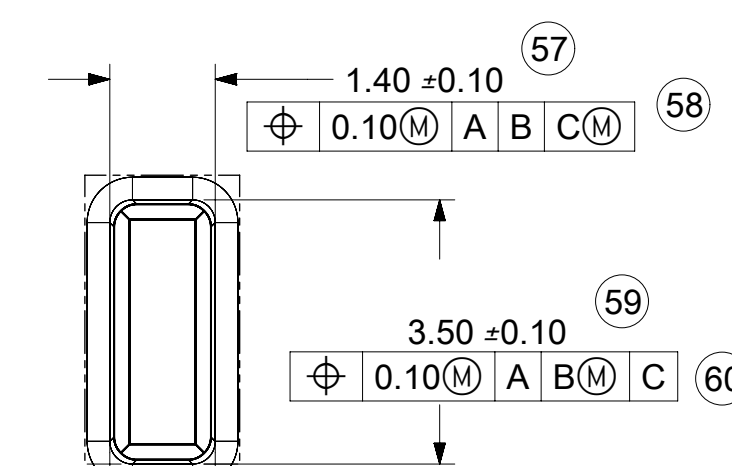
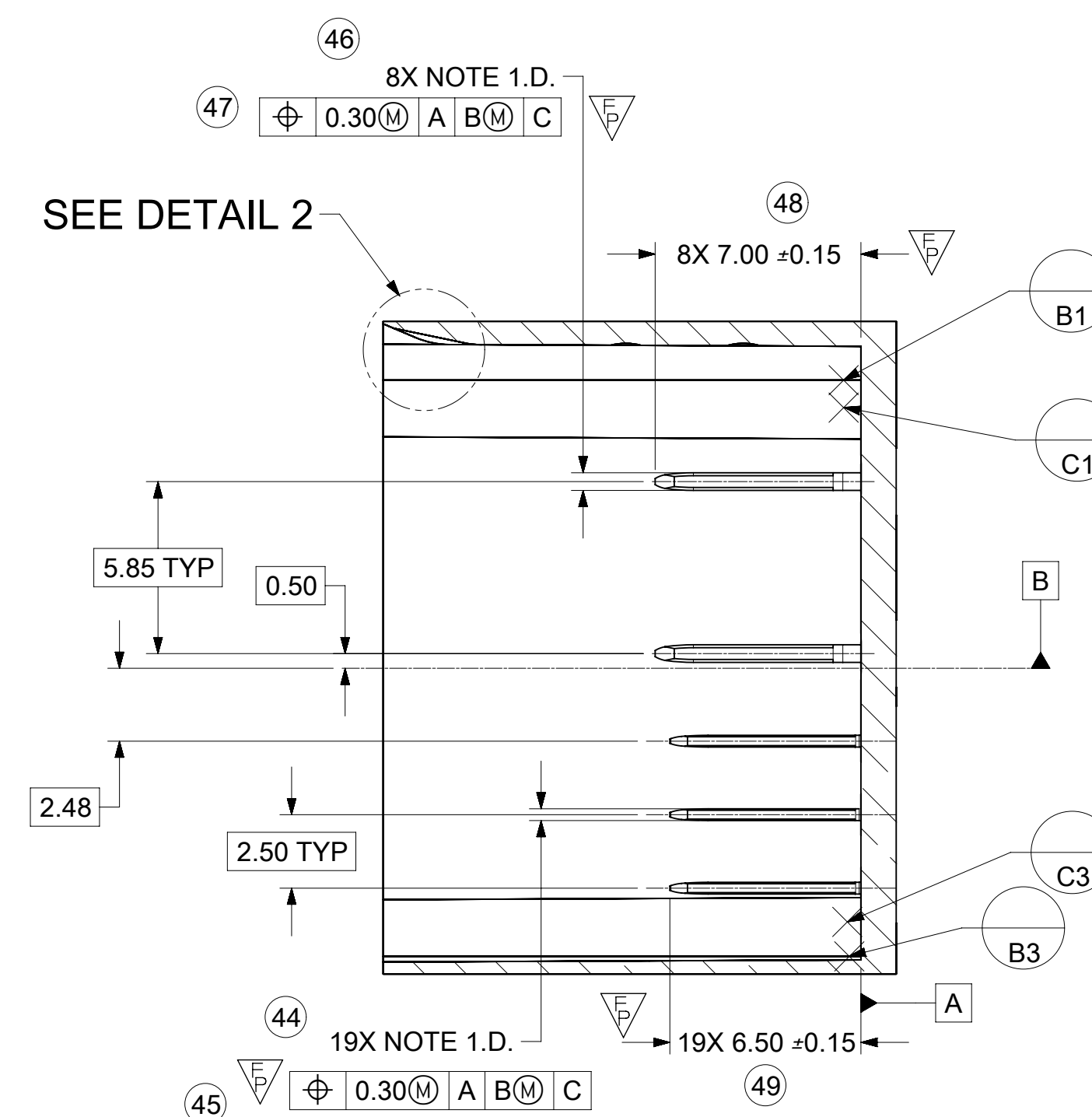

DETAIL 8  
SCALE 10:1

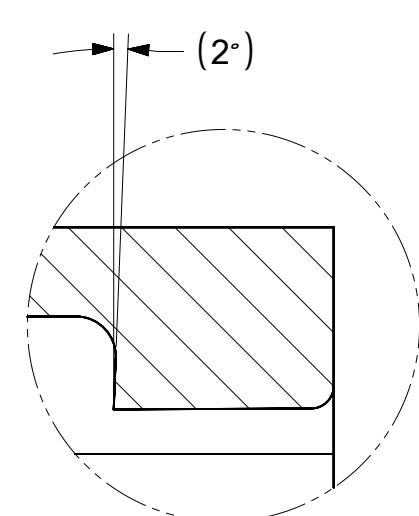

DETAIL 4  
SCALE 15:1

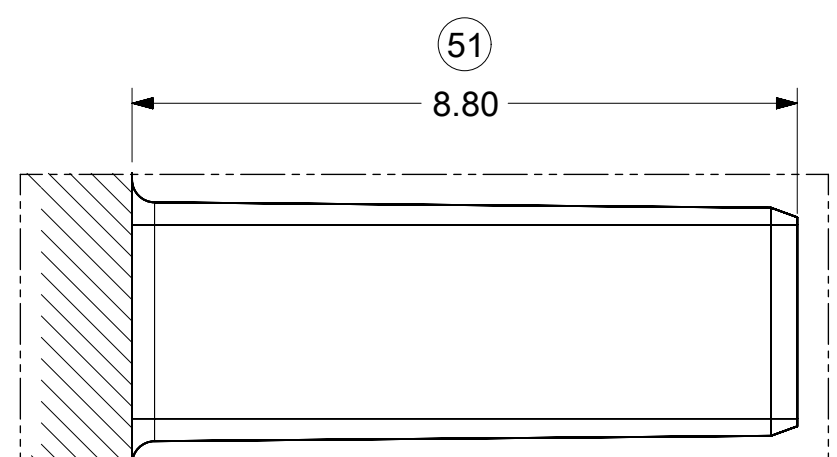

DETAIL 6  
SCALE 10:1

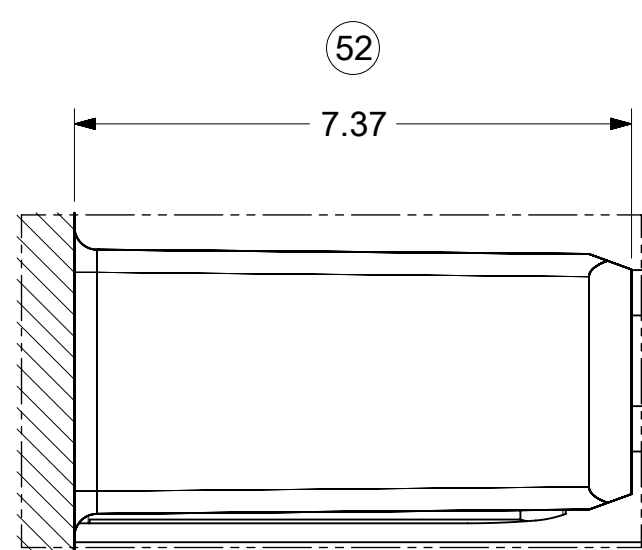

DETAIL 7  
SCALE 10:1

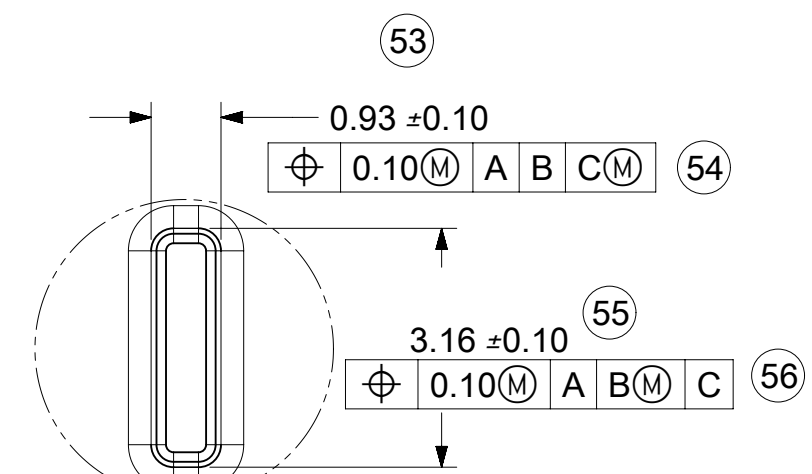

DETAIL 5  
SCALE 10:1

SYMBOLS	THIS DRAWING CONTAINS INFORMATION THAT IS PROPRIETARY TO MOLEX ELECTRONIC TECHNOLOGIES, LLC AND SHOULD NOT BE USED WITHOUT WRITTEN PERMISSION		
	DIMENSION UNITS	SCALE	CURRENT REV DESC: ADDED DIMENSION BALLOONS
▽ = 0	mm	5:1	
▽ = 0	GENERAL TOLERANCES (UNLESS SPECIFIED)		
▽ = 6	ANGULAR TOL ± °		
▽ = 0	4 PLACES	±	
▽ = 0	3 PLACES	±	
▽ = 0	2 PLACES	±	
▽ = 0	1 PLACE	±	
▽ = 0	0 PLACES	±	
■ = 0	DRAFT WHERE APPLICABLE MUST REMAIN WITHIN DIMENSIONS		
▽ = 0	THIRD ANGLE PROJECTION	DRAWING	SERIES
		D-SIZE	160029
EC NO: 602204		DRWN: JCONDON	2018/08/02
CHK'D: JCONDON		APPR: MVANSLAMBROU	2018/08/03
INITIAL REVISION:		DRWN: DAHALL	2013/11/20
		APPR: KDEKOSKI	2014/01/02
DOCUMENT NUMBER		DOC TYPE	DOC PART
SD-160029-002		PSD	001
REVISION		B1	
MATERIAL NUMBER		CUSTOMER	SHEET NUMBER
		GENERAL MARKET	2 OF 3

PACKAGE SPACE  
FOR CONNECTOR

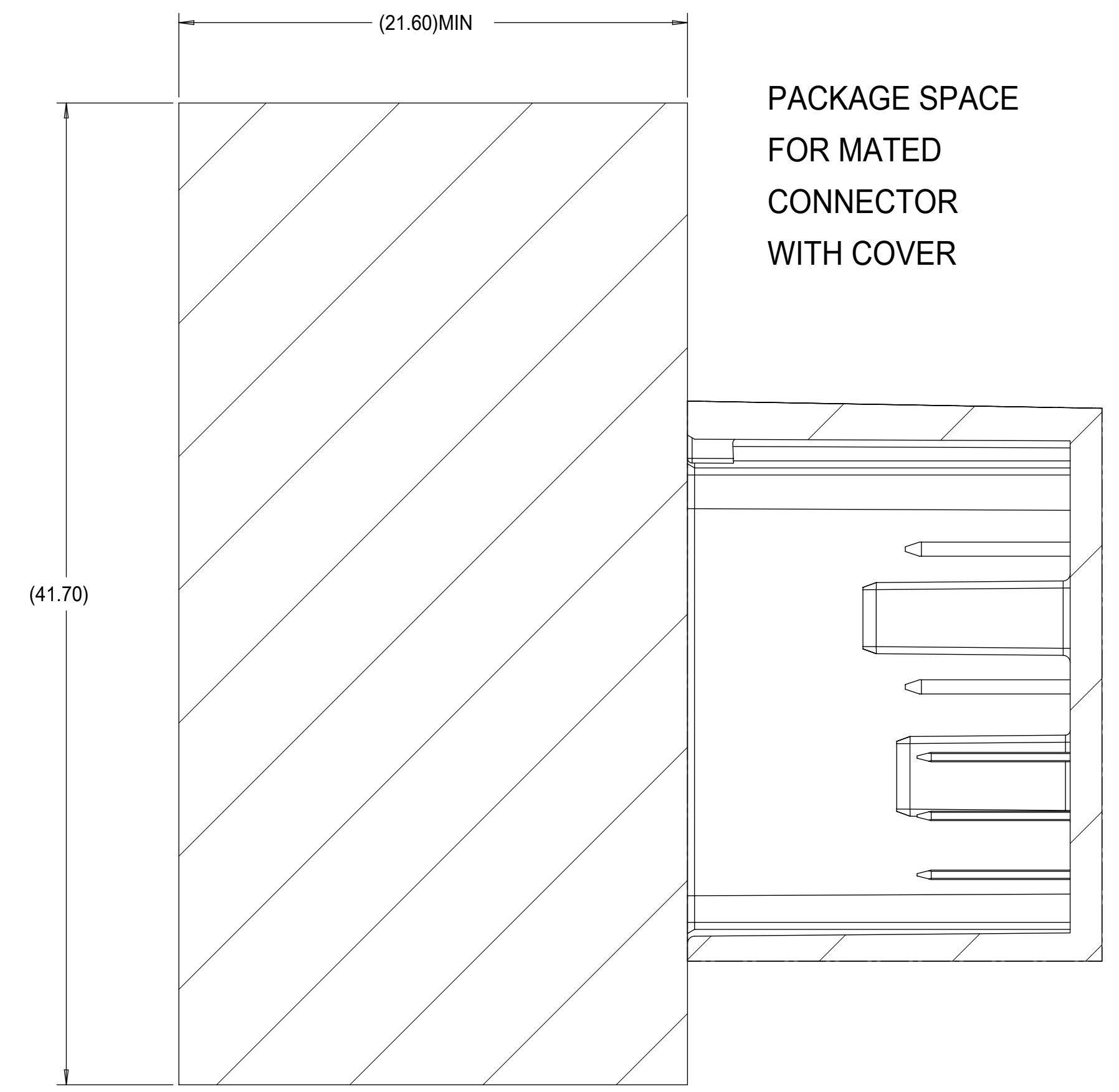
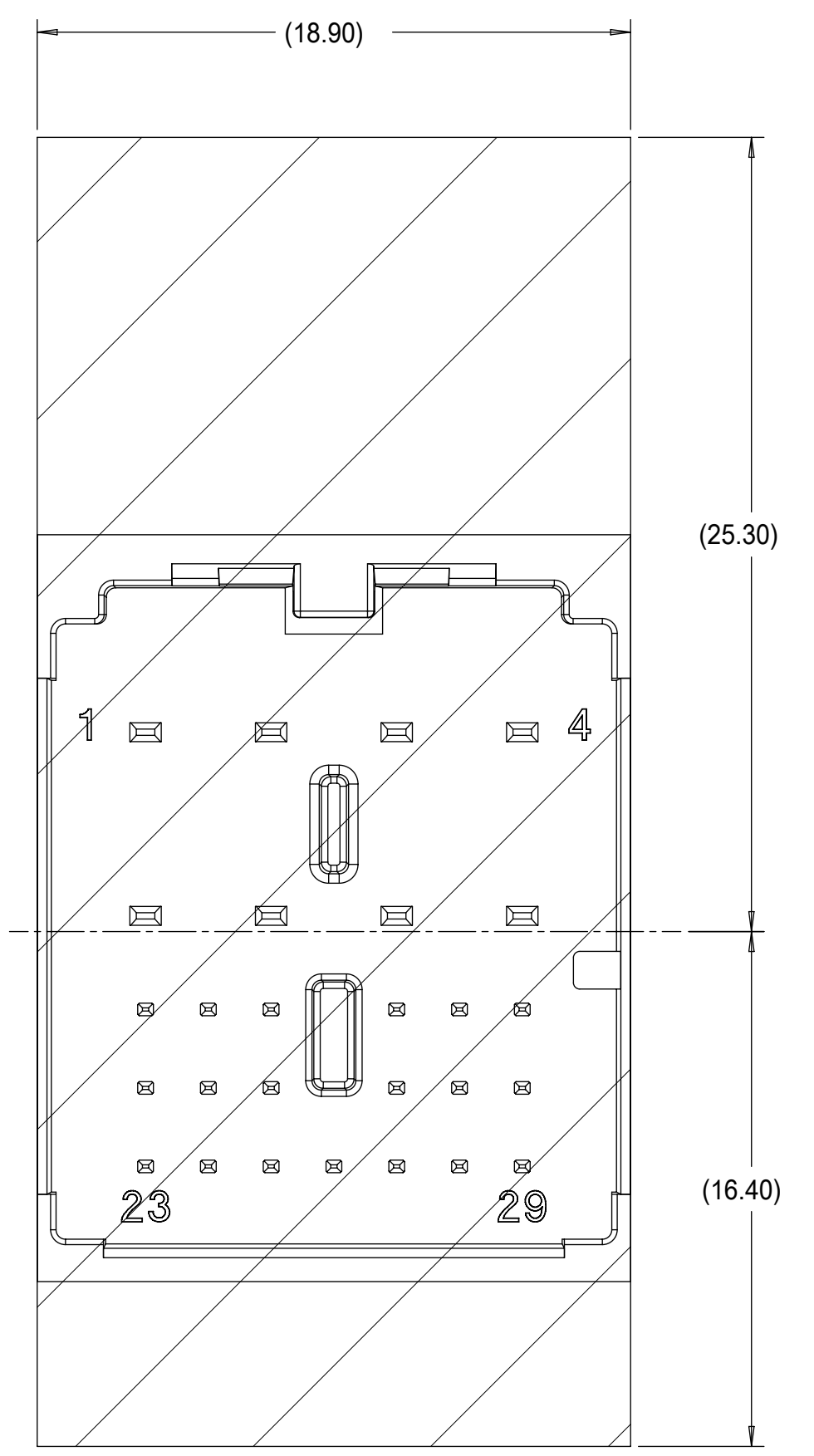
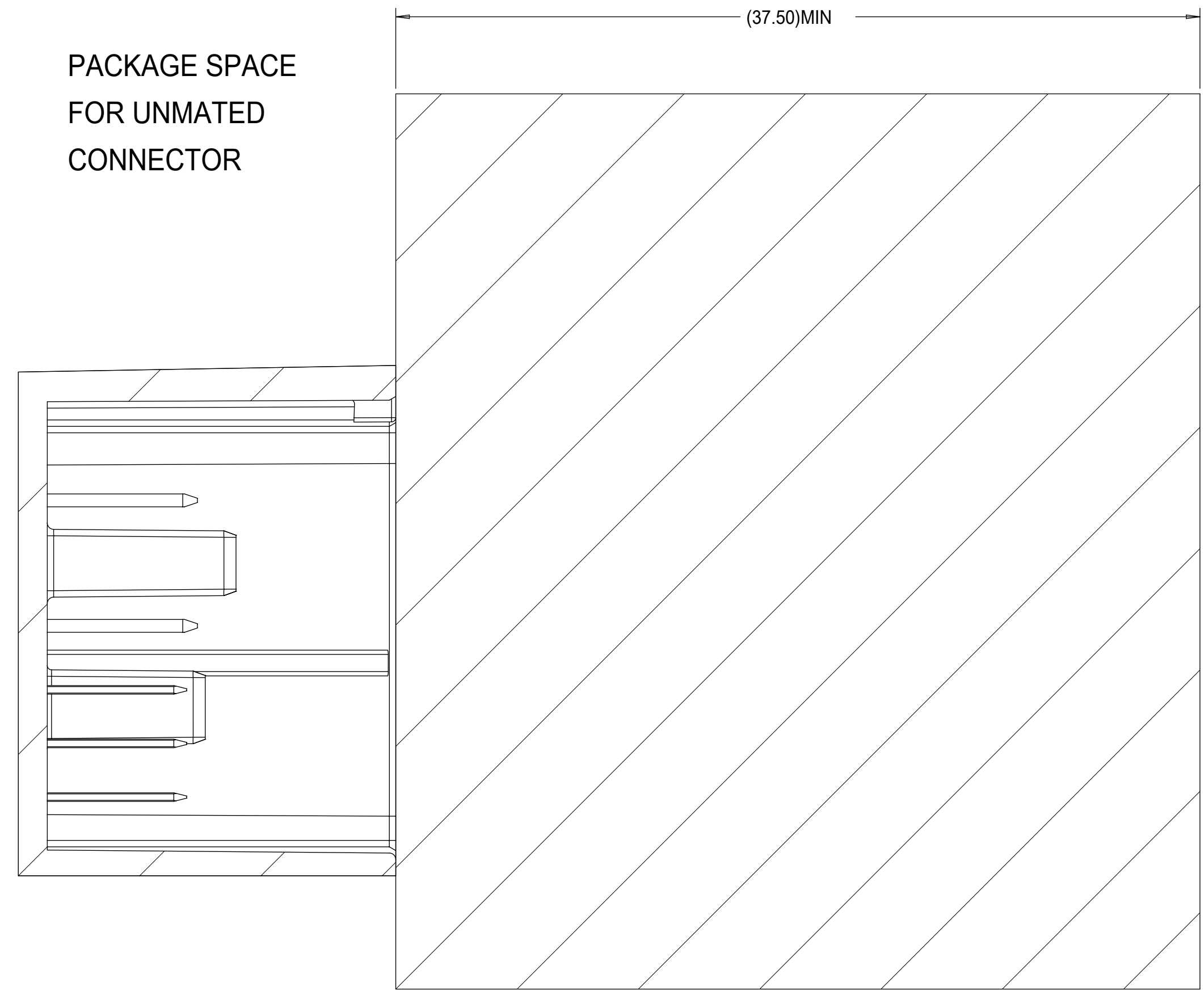

SYMBOLS	THIS DRAWING CONTAINS INFORMATION THAT IS PROPRIETARY TO MOLEX ELECTRONIC TECHNOLOGIES, LLC AND SHOULD NOT BE USED WITHOUT WRITTEN PERMISSION		
	DIMENSION UNITS	SCALE	CURRENT REV DESC: ADDED DIMENSION BALLOONS
▽ = 0	mm	5:1	<p><b>molex</b></p> <p>27WAY STAK50H INTERFACE DRAWING</p> <p>PRODUCT CUSTOMER DRAWING</p>
▽ = 0	GENERAL TOLERANCES (UNLESS SPECIFIED)		
▽ = 0	ANGULAR TOL ± °		
▽ = 0	4 PLACES	±	
▽ = 0	3 PLACES	±	
▽ = 0	2 PLACES	±	EC NO: 602204
▽ = 0	1 PLACE	±	DRWN: JCONDON 2018/08/02
□ = 0	0 PLACES	±	CHK'D: JCONDON 2018/08/03
■ = 0	DRAFT WHERE APPLICABLE MUST REMAIN WITHIN DIMENSIONS		APPR: MVANSLAMBROU 2018/08/03
▽ = 0	THIRD ANGLE PROJECTION		INITIAL REVISION:
	DRAWING		DRWN: DAHALL 2013/11/20
	SERIES		APPR: KDEKOSKI 2014/01/02
	D-SIZE		160029
	MATERIAL NUMBER		SD-160029-002
	CUSTOMER		GENERAL MARKET
	SHEET NUMBER		3 OF 3