

PRODUCT NUMBER
SEE TABLE

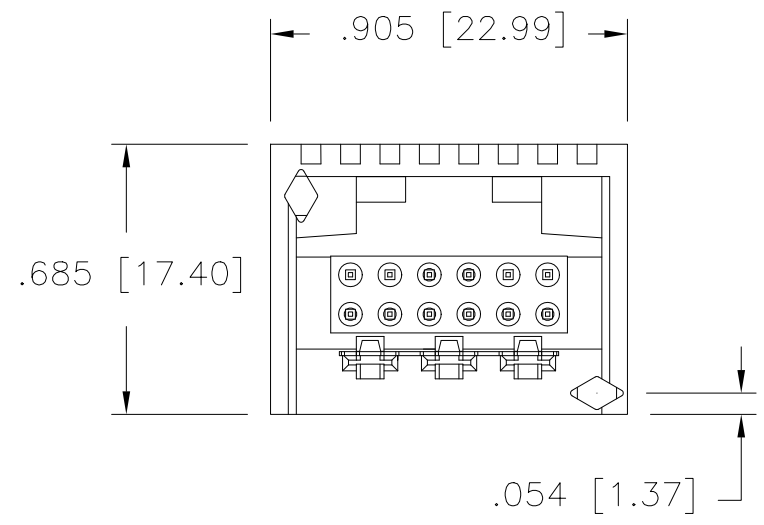

mat'l. code		surface ISO 1302 ✓		tolerance ISO 406 ISO 1101		projection ASME Y14.5		product family LATCH-N-LOK	
ltr ecn nodr date		tolerances unless otherwise specified		title		INCH/MM		2X6 LNL VERTICAL HEADER ASSEMBLY	
L	ELX-N-008444	ZK	11/29/11	angles	linea	.XX±.01/0.XX±0.3	scale 2:1	dwg no	
F	M04-0230	MHT	12/8/04	0°±2°		.XXX±.005/0.XXX±0.13		sheet 1 of 2	
G	M05-0052	ERE	3/19/05	chr	M. CORNMANN	.XXX±.0020/0.XXX±0.05	size		
H	M06-0285	AGS	7/28/06	engr	D. HORCHLER		A3		
J	M06-0365	AGS	9/20/06	chr	D. HORCHLER		69694		
K	M09-0048	MHT	3/12/09	app	D. HORCHLER		type Product Customer Drawing		
sheet	revision	L	L						
index	sheet	1	2						

FCI
FCIconnect.com
Copyright FCI

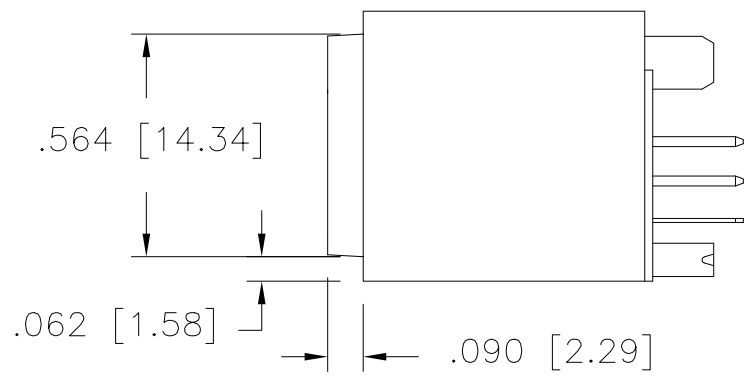
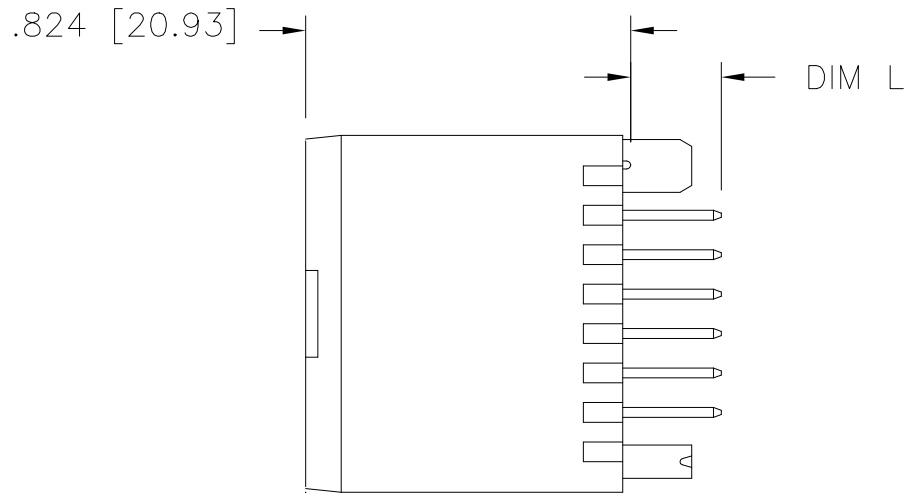