

PI6C557-05B

PCIe® 3.0 Clock Generator with 4 HCSL Outputs

Features

- PCIe® 3.0 complaint
 - PCIe 3.0 Phase jitter: 0.48ps RMS (High Freq. Typ.)
- LVDS compatible outputs
- Supply voltage of 3.3V ±5%
- 25MHz crystal or clock input frequency
- HCSL outputs, 0.7V Current mode differential pair
- Jitter 40ps cycle-to-cycle (typ)
- Spread of -0.5%, -1.0%, -1.5%, and no spread
- Industrial temperature range
- Spread Bypass option available
- Spread and frequency selection via external pins
- Totally Lead-Free & Fully RoHS Compliant (Notes 1 & 2)
- Halogen and Antimony Free. “Green” Device (Note 3)
- For automotive applications requiring specific change control (i.e. parts qualified to AEC-Q100/101/200, PPAP capable, and manufactured in IATF 16949 certified facilities), please [contact us](https://www.diodes.com/contact-us) or your local Diodes representative.
- <https://www.diodes.com/quality/product-definitions/>
- Packaging: (Pb-free and Green)
 - 20-pin, TSSOP (L)

Description

The PI6C557-05B is a spread spectrum clock generator compliant to PCI Express® 3.0 and Ethernet requirements. The device is used for PC or embedded systems to substantially reduce Electromagnetic Interference (EMI).

The PI6C557-05B provides four differential (HCSL) or LVDS spread spectrum outputs. The PI6C557-05B is configured to select spread and clock selection. Using Pericom's patented Phase-Locked Loop (PLL) techniques, the device takes a 25MHz crystal input and produces four pairs of differential outputs (HCSL) at 100MHz and 200MHz clock frequencies. It also provides spread selection of -0.5%, -1.0%, -1.5%, and no spread.

Block Diagram

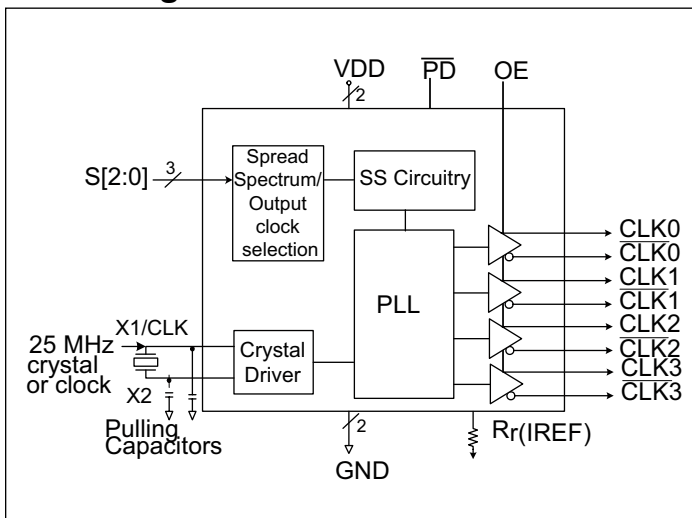

Pin Configuration

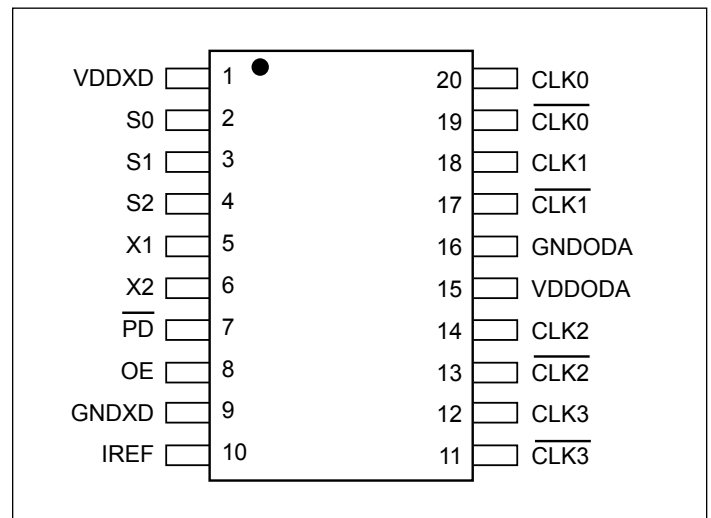

Notes:

1. No purposely added lead. Fully EU Directive 2002/95/EC (RoHS), 2011/65/EU (RoHS 2) & 2015/863/EU (RoHS 3) compliant.
2. See <https://www.diodes.com/quality/lead-free/> for more information about Diodes Incorporated's definitions of Halogen- and Antimony-free, "Green" and Lead-free.
3. Halogen- and Antimony-free "Green" products are defined as those which contain <900ppm bromine, <900ppm chlorine (<1500ppm total Br + Cl) and <1000ppm antimony compounds.

Pin Description

Pin #	Pin Name	I/O Type	Description
1	VDDXD	Power	Connect to a +3.3V source.
2	S0	Input	Spread Spectrum Select pin #0. See Spread Spectrum Selec table. Internal pull-up resistor.
3	S1	Input	Spread Spectrum Select pin #1. See Spread Spectrum Selec table. Internal pull-up resistor.
4	S2	Input	Spread Spectrum Select pin #2. See Spread Spectrum Selec table. Internal pull-up resistor.
5	X1	Input	Crystal connection.
6	X2	Output	Crystal connection.
7	$\overline{\text{PD}}$	Input	Power down. Internal pull-up resistor.
8	OE	Input	Output enable. Tri-states output (High=enable outputs); Low=disable outputs). Internal pull-up resistor.
9	GND	Power	Connect to digital circuit ground.
10	$\overline{\text{IREF}}$	Output	Precision resistor attached to this pin is connected to the internal current reference.
11	$\overline{\text{CLK3}}$	Output	Selectable 100/200 MHz Spread Spectrum differential compliment output clock 3.
12	CLK3	Output	Selectable 100/200 MHz Spread Spectrum differential true output clock 3.
13	$\overline{\text{CLK2}}$	Output	Selectable 100/200 MHz Spread Spectrum differential compliment output clock 2.
14	CLK2	Output	Selectable 100/200 MHz Spread Spectrum differential true output clock 2.
15	VDDODA	Power	Connect to a +3.3V analog source.
16	GND	Power	Output and Analog circuit ground
17	$\overline{\text{CLK1}}$	Output	Selectable 100/200 MHz Spread Spectrum differential compliment output clock 1.
18	CLK1	Output	Selectable 100/200 MHz Spread Spectrum differential true output clock 1.
19	$\overline{\text{CLK0}}$	Output	Selectable 100/200 MHz Spread Spectrum differential compliment output clock 0.
20	CLK0	Output	Selectable 100/200 MHz Spread Spectrum differential true output clock 0.

Table 2: Spread Selection Table

S2	S1	S0	Spread %	Spread Type	Output Frequency
0	0	0	-0.5	Down	100
0	0	1	-1.0	Down	100
0	1	0	-1.5	Down	100
0	1	1	No Spread	Not Applicable	100
1	0	0	-0.5	Down	200
1	0	1	-1.0	Down	200
1	1	0	-1.5	Down	200
1	1	1	No Spread	Not Applicable	200

Application Information

Decoupling Capacitors

Decoupling capacitors of 0.01 μ F or 0.1 μ F must be connected between each VDD pin and the PCB ground plane and placed as close to the VDD pin as possible.

PI6C557-05B must be isolated from system power supply noise to perform optimally.

Crystal

Use a 25MHz fundamental mode parallel resonant crystal with less than 30PPM of error across temperature.

Current Source (Iref) Reference Resistor - R_R

If board target trace impedance is 50-Ohm, then $R_R = 475$ -Ohm providing an IREF of 2.32 mA. The output current (IOH) is 6*IREF.

Output Termination

The PCI-Express differential clock outputs of the PI6C557-05B are open source drivers and require an external series resistor and a resistor to ground. These resistor values and their allowable locations are shown in detail in the PCI-Express Layout Guidelines section.

The PI6C557-05B can be configured for LVDS compatible voltage levels. See the LVDS Compatible Layout Guidelines section.

Output Structures

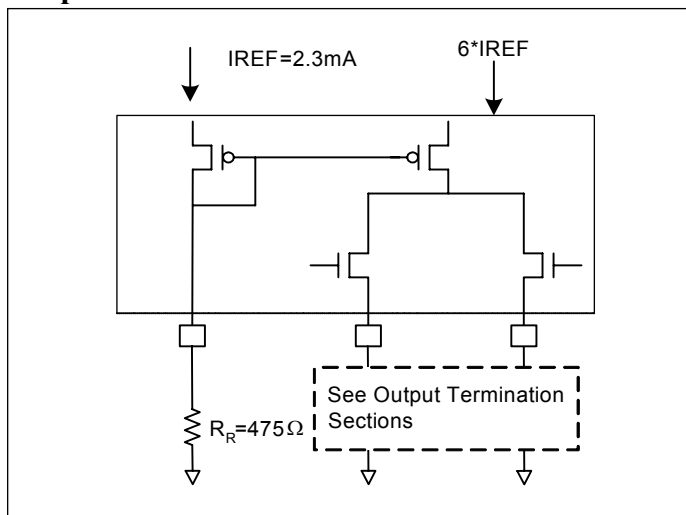

PCI-Express Layout Guidelines

Common Recommendations for Differential Routing	Dimension or Value	Unit
L1 length, route as non-coupled 50-Ohm trace.	0.5 max	inch
L2 length, route as non-coupled 50-Ohm trace.	0.2 max	inch
L3 length, route as non-coupled 50-Ohm trace.	0.2 max	inch
R_S	33	Ohm
R_T	49.9	Ohm

Differential Routing on a Single PCB	Dimension or Value	Unit
L4 length, route as coupled microstrip 100-Ohm differential trace.	2 min to 16 max	inch
L4 length, route as coupled stripline 100-Ohm differential trace.	1.8 min to 14.4 max	inch

Differential Routing to a PCI Express connector	Dimension or Value	Unit
L4 length, route as coupled microstrip 100-Ohm differential trace.	0.25 min to 14 max	inch
L4 length, route as coupled stripline 100-Ohm differential trace.	0.225 min to 12.6 max	inch

PCI-Express Device Routing

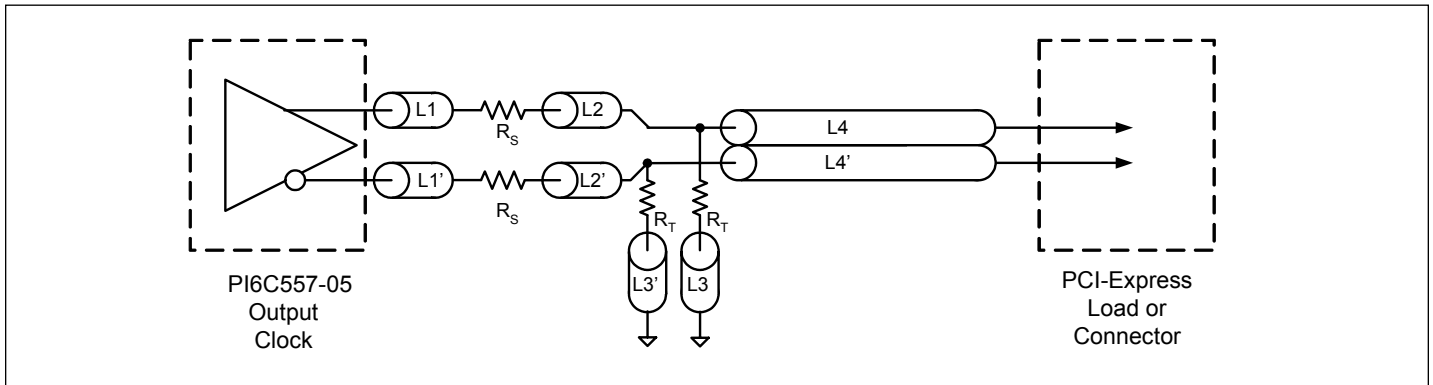

Typical PCI-Express (HCSL) Waveform

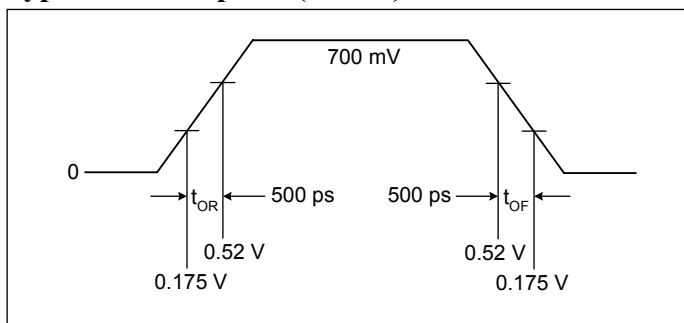

Application Information

LVDS Recommendations for Differential Routing	Dimension or Value	Unit
L1 length, route as non-coupled 50-Ohm trace.	0.5 max	inch
L2 length, route as non-coupled 50-Ohm trace.	0.2 max	inch
R_P	100	Ohm
R_Q	100	Ohm
R_T	150	Ohm
L3 length, route as 100Ω differential trace.		
L3 length, route as 100Ω differential trace.		

LVDS Device Routing

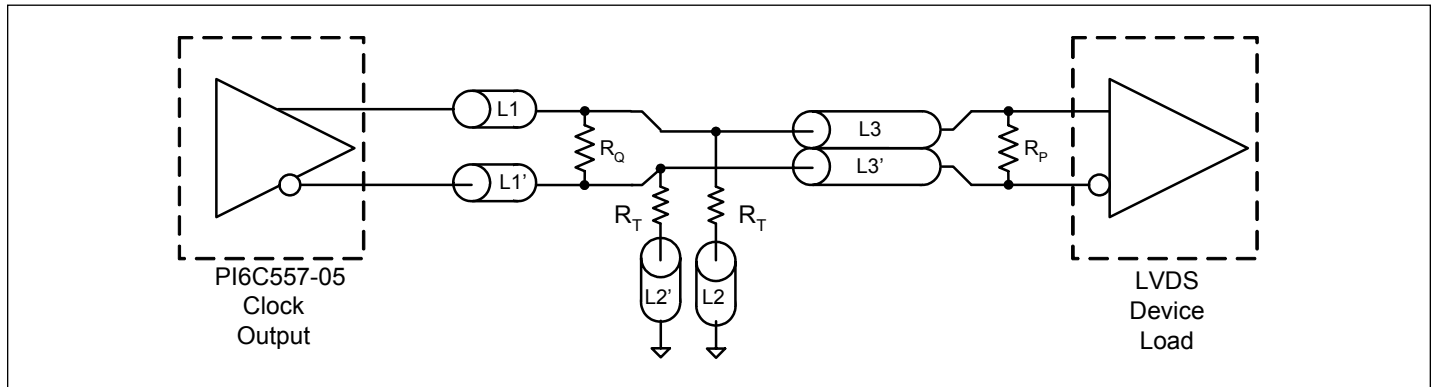

Typical LVDS Waveform

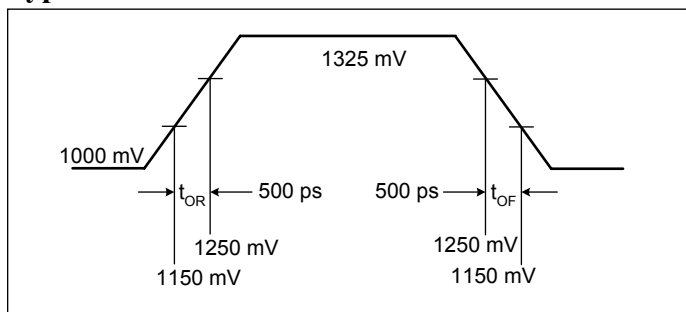

Electrical Specifications

Maximum Ratings

Supply Voltage to Ground Potential.....	5.5V
All Inputs and Outputs	-0.5V to V _{DD} +0.5V
Ambient Operating Temperature	-40 to +85°C
Storage Temperature	-65 to +150°C
Junction Temperature	125°C
ESD Protection (Input)	2000V min (HBM)

Note:

Stresses greater than those listed under MAXIMUM RATINGS may cause permanent damage to the device. This is a stress rating only and functional operation of the device at these or any other conditions above those indicated in the operational sections of this specification is not implied. Exposure to absolute maximum rating conditions for extended periods may affect reliability.

Recommended Operation Conditions

Parameter	Min.	Typ.	Max.	Unit
Ambient Operating Temperature	-40		+85	°C
Power Supply Voltage (measured in respect to GND)	3.135		3.465	V

DC Characteristics (V_{DD} = 3.3V ±5%, T_A = -40°C to +85°C)

Symbol	Parameter	Conditions	Min.	Typ.	Max.	Unit
V _{DD}	Supply Voltage		3.135	3.3	3.465	V
V _{IH}	Input High Voltage ⁽¹⁾		2.0		V _{DD} +0.3	V
V _{IL}	Input Low Voltage ⁽¹⁾		GND -0.3		0.8	V
I _{IL}	Input Leakage Current	0 < V _{in} < V _{DD} Without input pull-up and pull-downs	-5		5	µA
I _{DD}	Operating Supply Current	R _L = 50Ω, C _L = 2pF @100MHz		105	130	mA
I _{DDOE}		OE = LOW		40	50	mA
I _{DDPD}		No load $\overline{\text{PD}}$ = LOW		60	100	µA
C _{IN}	Input Capacitance	Input pin capacitance			7	pF
C _{OUT}	Output Capacitance	Output pin capacitance			6	pF
L _{PIN}	Pin Inductance				5	nH
R _{OUT}	Output Resistance	CLK Outputs	3.0			kΩ

Note:

- Single edge is monotonic when transitioning through region.

AC Characteristics (V_{DD} = 3.3V ±5%, T_A = -40°C to +85°C)

Symbol	Parameter	Conditions	Min.	Typ.	Max.	Unit
F _{IN}	Input Frequency			25		MHz
V _{OUT}	Output Frequency	HCSL terminal			200	MHz
		LVDS terminal			100	
V _{OH}	Output High Voltage ^(1,2)	@V _{DD} = 3.3V	660	700	850	mV
V _{OL}	Output Low Voltage ^(1,2)		-150	0	27	mV
V _{CPA}	Crossing Point Voltage ^(1,2)	Absolute	250	350	550	mV
V _{CN}	Crossing Point Voltage ^(1,2,4)	Variation over all edges			140	mV
J _{CC}	Jitter, Cycle-to-Cycle ^(1,3)			40	60	ps
J _{RMS2.0}	PCIe 2.0 RMS Jitter	PCI-SIG jitter test method			3.1	ps

AC Characteristics Cont.

Symbol	Parameter	Conditions	Min.	Typ.	Max.	Unit
$J_{RMS3.0}$	PCIe 3.0 RMS Jitter	PLL L-BW @ 2M & 5M 1st H3		2.1	3	ps
		PLL L-BW @ 2M & 4M 1st H3		2.38	3	ps
		PLL H-BW @ 2M & 5M 1st H3		0.48	1	ps
		PLL H-BW @ 2M & 4M 1st H3		0.47	1	ps
MF	Modulation Frequency	Spread Spectrum	30	31.5	33	kHz
t_{OR}	Rise Time ^(1,2)	From 0.175V to 0.525V	175	332	700	ps
t_{OF}	Fall Time ^(1,2)	From 0.525V to 0.175V	175	344	700	ps
T_{SKEW}	Skew between outputs	At Crossing Point Voltage			50	ps
$T_{DUTY-CYCLE}$	Duty Cycle ^(1,3)		45		55	%
T_{OE}	Output Enable Time ⁽⁵⁾	All outputs			10	μ s
T_{OT}	Output Disable Time ⁽⁵⁾	All outputs			10	μ s
t_{STABLE}	From power-up to VDD=3.3V	From Power-up VDD=3.3V		3.0		ms
t_{SPREAD}	Setting period after spread change	Setting period after spread change		3.0		ms

Notes:

1. $R_L = 50\text{-}\Omega$ with $C_L = 2\text{ pF}$ and R_R
2. Single-ended waveform
3. Differential waveform
4. Measured at the crossing point
5. CLK pins are tri-stated when OE is LOW

Thermal Characteristics

Symbol	Parameter	Conditions	Min.	Typ.	Max.	Unit
θ_{JA}	Thermal Resistance Junction to Ambient	Still air			93	$^{\circ}\text{C/W}$
θ_{JB}	Thermal Resistance Junction to Board				54	$^{\circ}\text{C/W}$
θ_{JC}	Thermal Resistance Junction to Case				20	$^{\circ}\text{C/W}$

Recommended Crystal Specification

Diodes recommends:

- a) GC2500003 XTAL 49S/SMD(4.0 mm), 25M, $C_L=18\text{pF}$, +/-30ppm
http://www.pericom.com/pdf/datasheets/se/GC_GF.pdf
- b) FY2500081, SMD 5x3.2(4P), 25M, $C_L=18\text{pF}$, +/-30ppm
http://www.pericom.com/pdf/datasheets/se/FY_F9.pdf
- c) FL2500047, SMD 3.2x2.5(4P), 25M, $C_L=18\text{pF}$, +/-20ppm
<http://www.pericom.com/pdf/datasheets/se/FL.pdf>

PI6C557-05B

Part Marking

PI6C557
-05BLE
YYWWXX
○

YY: Year

WW: Workweek

1st X: Assembly Code

2nd X: Fab Code

Packaging Mechanical: 20-TSSOP (L)

SYMBOLS	MIN.	NOM.	MAX.
A	—	—	1.20
A1	0.05	—	0.15
A2	0.80	1.00	1.05
b	0.19	—	0.30
C	0.09	—	0.20
D	6.40	6.50	6.60
E1	4.30	4.40	4.50
E	6.20	6.40	6.60
e	0.65 BSC		
L1	1.00 REF		
L	0.45	0.60	0.75
S	0.20	—	—
θ	0°	—	8°

NOTES:
 1. ALL DIMENSIONS IN MILLIMETERS. ANGLES IN DEGREES.
 2. JEDEC MO-153F
 3. DIMENSIONS DOES NOT INCLUDE MOLD FLASH, PROTRUSIONS OR GATE BURRS.

16-0074

		DATE: 03/31/16
DESCRIPTION: 20-Pin, 173mil Wide TSSOP		
PACKAGE CODE: L (L20)		
DOCUMENT CONTROL #: PD-1311	REVISION: G	

For latest package info.

please check: <http://www.diodes.com/design/support/packaging/pericom-packaging/packaging-mechanicals-and-thermal-characteristics/>

Ordering Information

Ordering Code	Package Code	Package Description
PI6C557-05BLEX	L	20-Pin, 173mil Wide (TSSOP)

Notes:

1. No purposely added lead. Fully EU Directive 2002/95/EC (RoHS), 2011/65/EU (RoHS 2) & 2015/863/EU (RoHS 3) compliant.
2. See <https://www.diodes.com/quality/lead-free/> for more information about Diodes Incorporated's definitions of Halogen- and Antimony-free, "Green" and Lead-free.
3. Halogen- and Antimony-free "Green" products are defined as those which contain <900ppm bromine, <900ppm chlorine (<1500ppm total Br + Cl) and <1000ppm antimony compounds.
4. E = Pb-free and Green
5. X suffix = Tape/Reel

IMPORTANT NOTICE

DIODES INCORPORATED MAKES NO WARRANTY OF ANY KIND, EXPRESS OR IMPLIED, WITH REGARDS TO THIS DOCUMENT, INCLUDING, BUT NOT LIMITED TO, THE IMPLIED WARRANTIES OF MERCHANTABILITY AND FITNESS FOR A PARTICULAR PURPOSE (AND THEIR EQUIVALENTS UNDER THE LAWS OF ANY JURISDICTION).

Diodes Incorporated and its subsidiaries reserve the right to make modifications, enhancements, improvements, corrections or other changes without further notice to this document and any product described herein. Diodes Incorporated does not assume any liability arising out of the application or use of this document or any product described herein; neither does Diodes Incorporated convey any license under its patent or trademark rights, nor the rights of others. Any Customer or user of this document or products described herein in such applications shall assume all risks of such use and will agree to hold Diodes Incorporated and all the companies whose products are represented on Diodes Incorporated website, harmless against all damages.

Diodes Incorporated does not warrant or accept any liability whatsoever in respect of any products purchased through unauthorized sales channel.

Should Customers purchase or use Diodes Incorporated products for any unintended or unauthorized application, Customers shall indemnify and hold Diodes Incorporated and its representatives harmless against all claims, damages, expenses, and attorney fees arising out of, directly or indirectly, any claim of personal injury or death associated with such unintended or unauthorized application.

Products described herein may be covered by one or more United States, international or foreign patents pending. Product names and markings noted herein may also be covered by one or more United States, international or foreign trademarks.

This document is written in English but may be translated into multiple languages for reference. Only the English version of this document is the final and definitive format released by Diodes Incorporated.

LIFE SUPPORT

Diodes Incorporated products are specifically not authorized for use as critical components in life support devices or systems without the express written approval of the Chief Executive Officer of Diodes Incorporated. As used herein:

A. Life support devices or systems are devices or systems which:

1. are intended to implant into the body, or

2. support or sustain life and whose failure to perform when properly used in accordance with instructions for use provided in the labeling can be reasonably expected to result in significant injury to the user.

B. A critical component is any component in a life support device or system whose failure to perform can be reasonably expected to cause the failure of the life support device or to affect its safety or effectiveness.

Customers represent that they have all necessary expertise in the safety and regulatory ramifications of their life support devices or systems, and acknowledge and agree that they are solely responsible for all legal, regulatory and safety-related requirements concerning their products and any use of Diodes Incorporated products in such safety-critical, life support devices or systems, notwithstanding any devices- or systems-related information or support that may be provided by Diodes Incorporated. Further, Customers must fully indemnify Diodes Incorporated and its representatives against any damages arising out of the use of Diodes Incorporated products in such safety-critical, life support devices or systems.

Copyright © 2020, Diodes Incorporated
www.diodes.com