

BQ21061EVM Evaluation Module

This user's guide provides detailed testing instructions for the BQ21061 evaluation module (EVM). Also included are descriptions of the necessary equipment, equipment setup, procedures, the printed-circuit board layouts, schematics, and the bill of materials (BOM).

Throughout this user's guide, the abbreviations *EVM*, *BQ21061EVM*, and the term *evaluation module* are synonymous with the BQ21061 evaluation module, unless otherwise noted.

Contents

1	Introduction	2
	1.1 EVM Features	2
	1.2 I/O Descriptions	2
2	Test Summary	4
	2.1 Equipment	4
	2.2 Charge Mode	5
	2.3 Ship Mode	6
	2.4 Warning	6
	2.5 Comparison Table	6
3	Board Layouts, Schematics, and Bill of Materials	7
	3.1 Board Layouts	7
	3.2 Schematics	12
	3.3 Bill of Materials	15

List of Figures

1	BQ21061EVM Connections	3
2	Connections for Test Setup	5
3	BQStudio Software Tool	6
4	Top Overlay	7
5	Top Layer	7
6	Signal Layer 1	8
7	Signal Layer 2	8
8	Bottom Layer	9
9	Bottom Overlay	9
10	Top Solder Mask	10
11	Bottom Solder Mask	10
12	Drill Drawing	11
13	Board Dimensions	11
14	BQ21061 Low Iq Battery Charger with PowerPath Management Schematic	12
15	BQ21061EVM Jumper Connectors	13
16	BQ21061EVM Interface Connector	13
17	User Menu Switches	14
18	LDO for Display/Other Peripherals	14

List of Tables

1	Device Data Sheet	2
---	-------------------------	---

2	Jumper Connections	2
3	Recommended Operating Conditions.....	3
4	Comparison Table	6
5	Bill of Materials	15

Trademarks

Microsoft, Windows are registered trademarks of Microsoft Corporation. All other trademarks are the property of their respective owners.

1 Introduction

The BQ21061EVM is an evaluation kit for the BQ21061 integrated battery charge management IC. The BQ21061 is an integrated battery charge management IC that integrates the most common functions for wearable devices: Linear charger, regulated output/ load switch, manual reset with timer, and ship mode function.

1.1 EVM Features

Key features of this EVM include:

- 500mA Linear battery charger
- I2C Configurable Battery Regulation Voltage with 0.5% Accuracy
- Configurable Termination Current down to 0.5mA
- Programmable thermal charging profile with configurable Hot, Warm, Cool and Cold thresholds
- Power Path Management for powering the system and charging the battery
- 10nA Ship Mode battery Iddq for longest shelf life
- One I2C Configurable Load Switch or 150mA LDO Output
- One Button Wake-up and Reset Input with Adjustable Timers
- I2C Communication Control

See the device data sheet ([SLUSDU0](#)) for detailed features and operation of the integrated circuit (IC).

Table 1. Device Data Sheet

Device	Data Sheet
BQ21061	SLUSDU0

1.2 I/O Descriptions

[Table 2](#) lists the jumper connections available on this EVM.

Table 2. Jumper Connections

Jumper Name	Description	Setting
J1	Micro USB connector (optional for VIN)	NA
J2, J3	Board connector to other modules	NA
J4	External LDO ON	Not Connected
J5	TS potentiometer connector	Connected
J6	VIN and GND connector	NA
J7	VBAT and GND connector	NA
J8	EV2400 Connector	NA
J10	Battery Pack Connector	NA
J11	VIO connector to VDD or 3p3V	Connect VDD to VIO
J12	/LP connector to GPIO or VIO	Connect /LP to VIO
J13	/CE connector ro GPIO or VIO	Connect /CE to VIO

Table 2. Jumper Connections (continued)

Jumper Name	Description	Setting
J14	Display connector for other modules	NA
J15	PMID to VINLS connector	Connected
J16	On board LED pullup to VDD or PMID	Connected to PMID
J17	I2C Pullup	Connected

Table 3 lists the recommended operating conditions for this EVM.

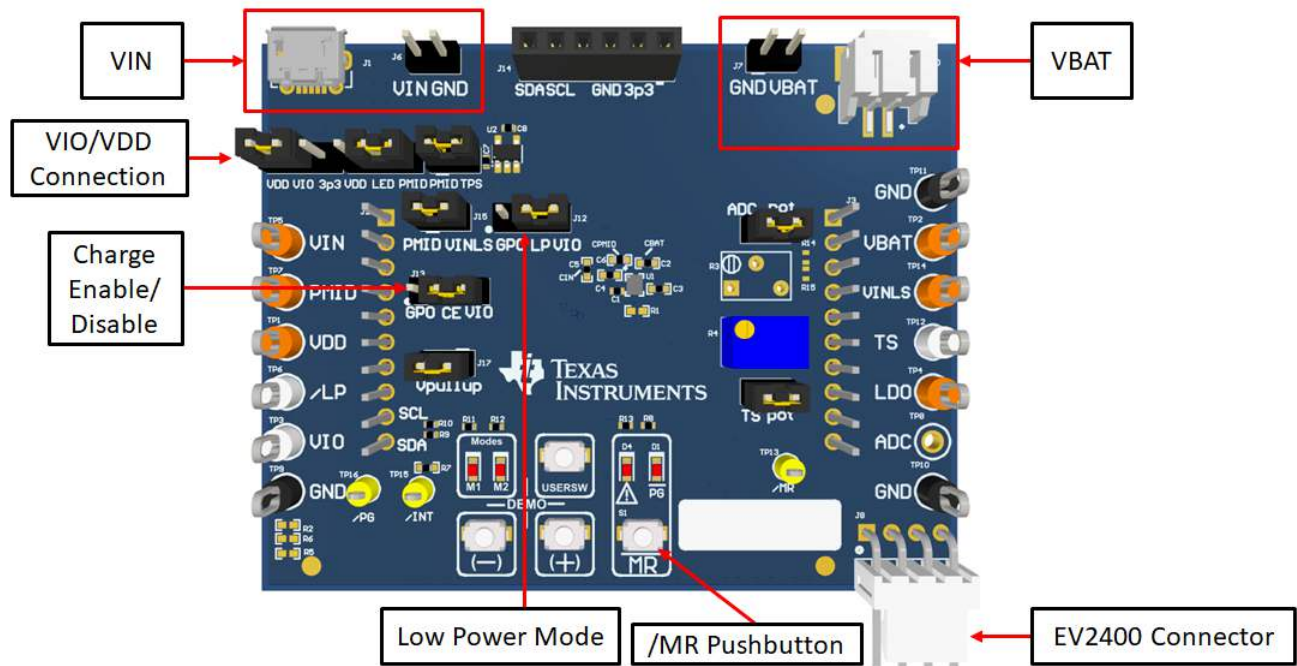

Figure 1. BQ21061EVM Connections

Table 3. Recommended Operating Conditions

Symbol	Description	MIN	TYP	MAX	Unit
Supply voltage, $V_{V_{BUS}}$	Input voltage from AC adapter		5	20	V
Battery voltage, $V_{V_{BAT}}$ in charge mode	Voltage applied at V_{BAT} terminal		4.2		V
I_{BAT}	Fast charging current		0.5		A
	Discharging current through internal MOSFET		1		A
Supply current, I_{IN}	Maximum input current from AC adapter input		0.6		A

2 Test Summary

2.1 Equipment

This section includes a list of supplies required to perform tests on this EVM.

1. *Powersupply (PS#1), Powersupply (PS#2)*: Keithley 2400 Powersupply or equivalent
2. *SC#1- SC#3*: 4 channel Oscilloscope
3. *Computer*: A computer with at least one USB port and a USB cable
4. *PC communication interface*:
5. *Software*: Download [bqStudio](#) from Texas Instruments
Double click the *Battery management studio* installation file and then follow the installation steps. The software supports Microsoft® Windows® 7 and Windows 10 operating systems.

2.2 Charge Mode

Connect the equipment as following:

Power supply PS#1: VIN of the BQ21061 at 5V

Power supply PS#2: VBAT of the BQ21061 at 3.7V

Scope channel SC#1: VIN

Scope channel SC#2: VPMID

Scope channel SC#3: VBAT

Turn ON the supply PS#2, then turn ON the supply PS#1. The VPMID will rise to ≈ 4.5 V. The device will begin to charge as long as /CE pin jumper is disconnected (J13 being pulled off will result in the pulldown internal to the device, charge enabled), the TS is left at default configuration and there are no other faults.

To adjust the charge current or change other parameters, connect the EV2400 to the EVM and then startup BQStudio.

Select the Charger_1_00-bq21061.bqz from the charger selection. Click “Read Register” to read all the registers and navigate to the Field View to make changes.

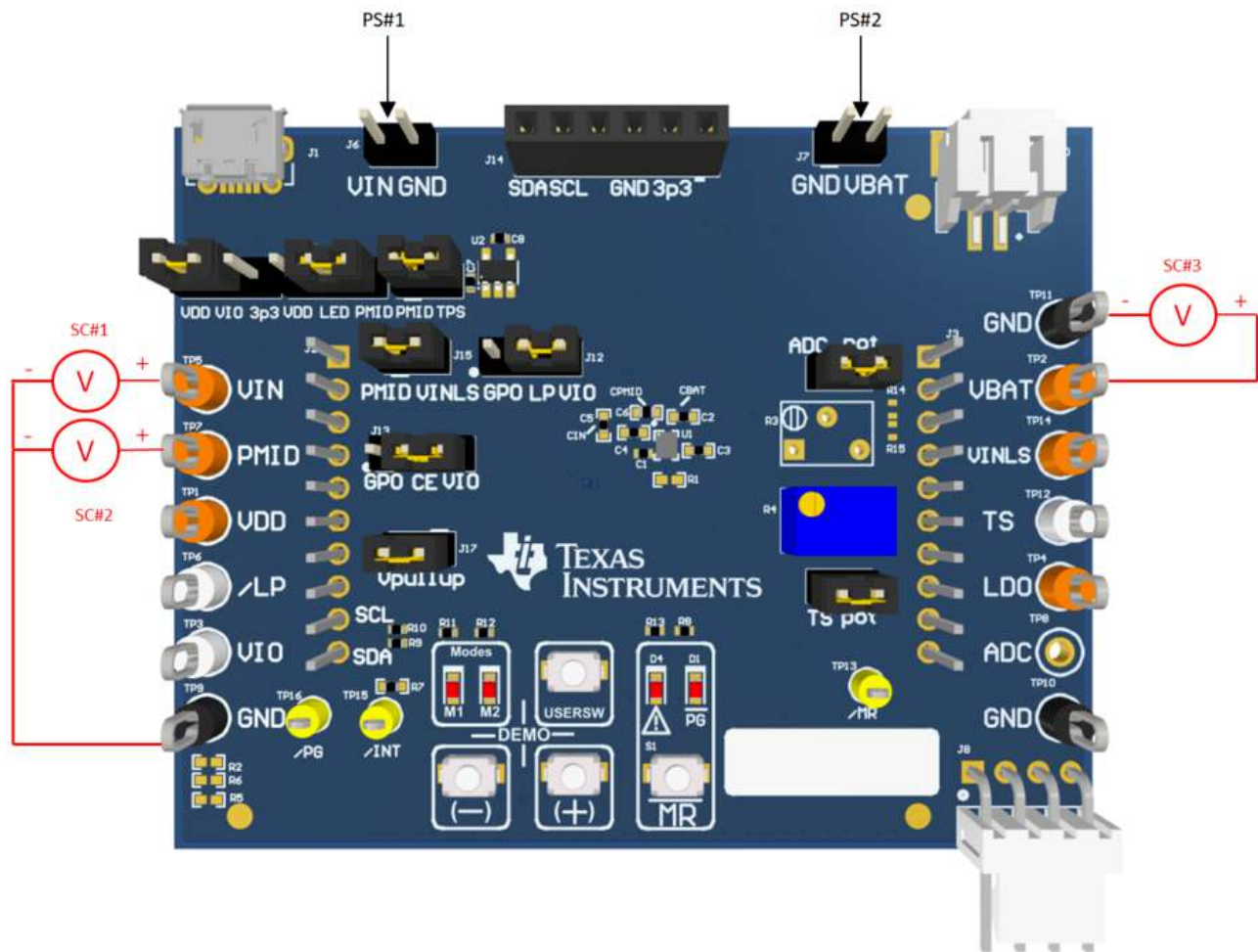

Figure 2. Connections for Test Setup

2.3 Ship Mode

To go to Ship Mode, turn OFF VIN (PS#1). Make sure /LP pin is connected to VIO(J12) and VIO is connected to VDD through J11. Read all the registers and click the Shipmode Enable checkbox (Bit B7 on register 0x35) to go to Ship Mode. You can know that you are in Ship Mode as the voltage on PMID (SC#2) will fall to 0V.

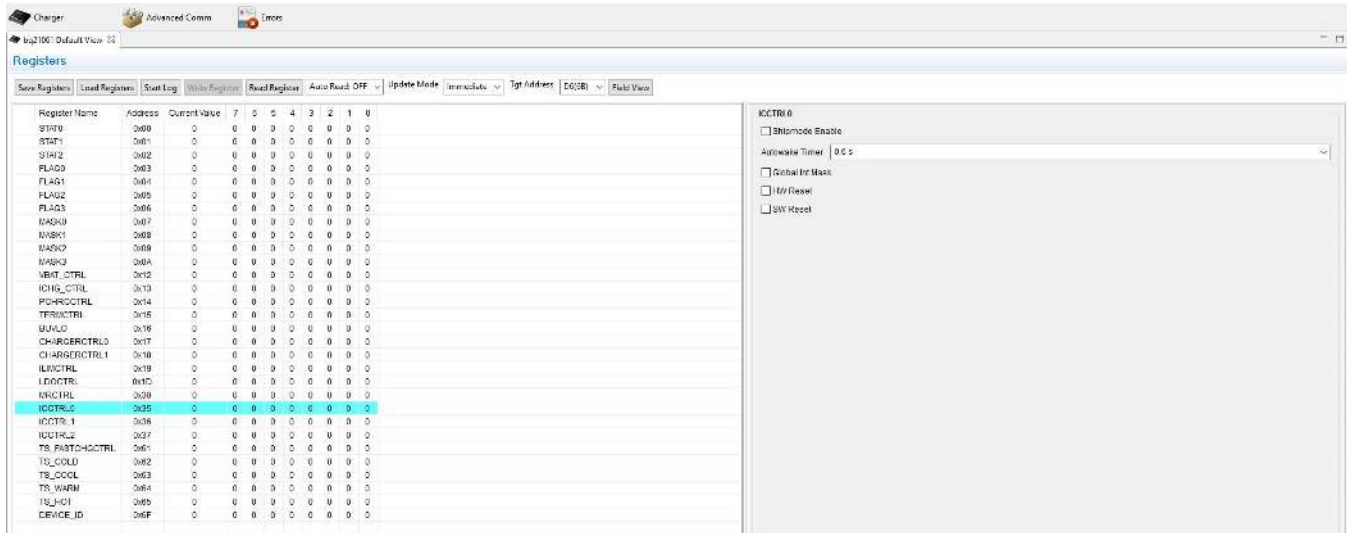

Figure 3. BQStudio Software Tool

2.4 Warning

The warning label indicates when there is a fault during communication with the MCU.

2.5 Comparison Table

Refer to the data sheet for detailed information on register defaults.

Table 4. Comparison Table

	BQ21061
Default PMID voltage when adapter is present	4.5 V (can be adjusted through I2C)
Input current limit default	500 mA
VINDPM	Disabled
Warm battery discharge	Yes (up to 20 mA)
Wake from Shipmode timer	125 ms
VINUVLO (battery present)	3.15 V
Device ID	0x3A

3 Board Layouts, Schematics, and Bill of Materials

3.1 Board Layouts

Figure 4 through Figure 12 show the PCB board layouts.

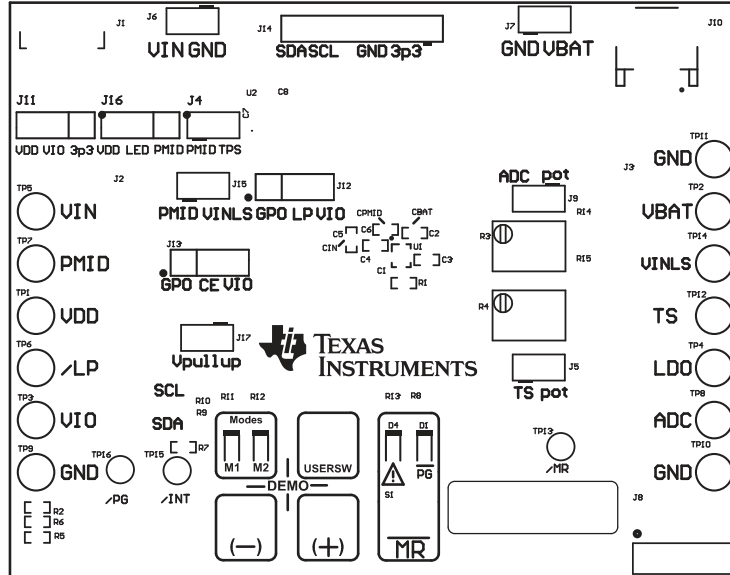

Figure 4. Top Overlay

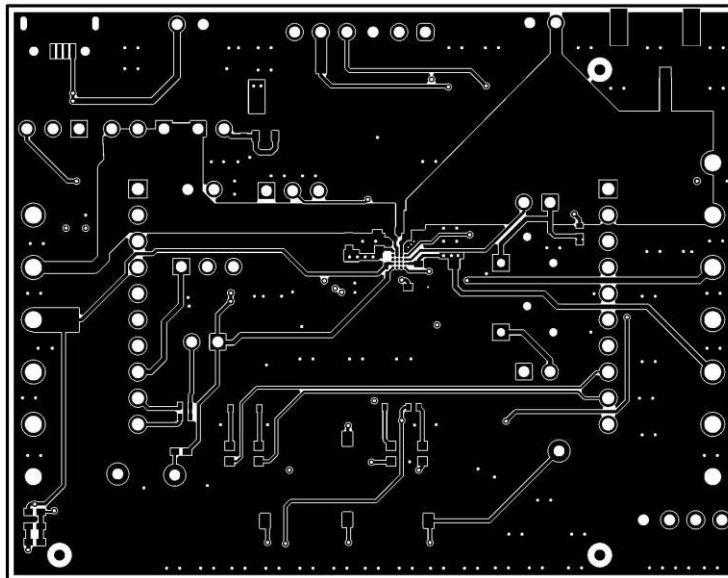

Figure 5. Top Layer

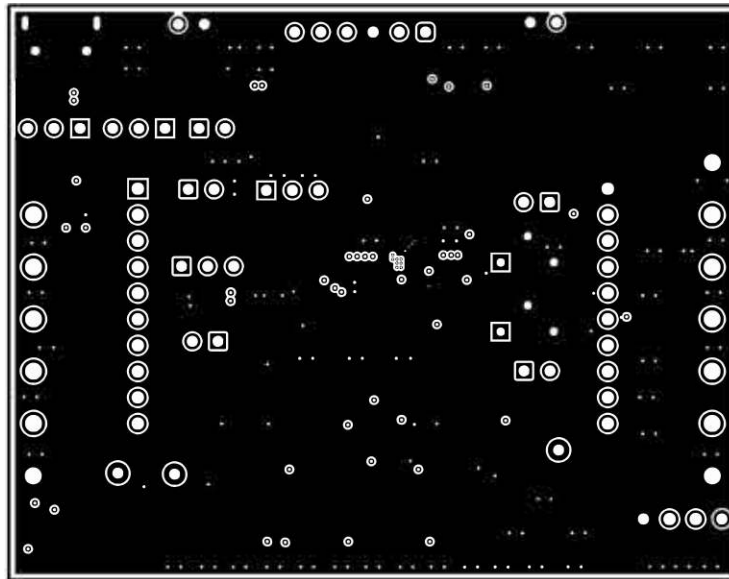

Figure 6. Signal Layer 1

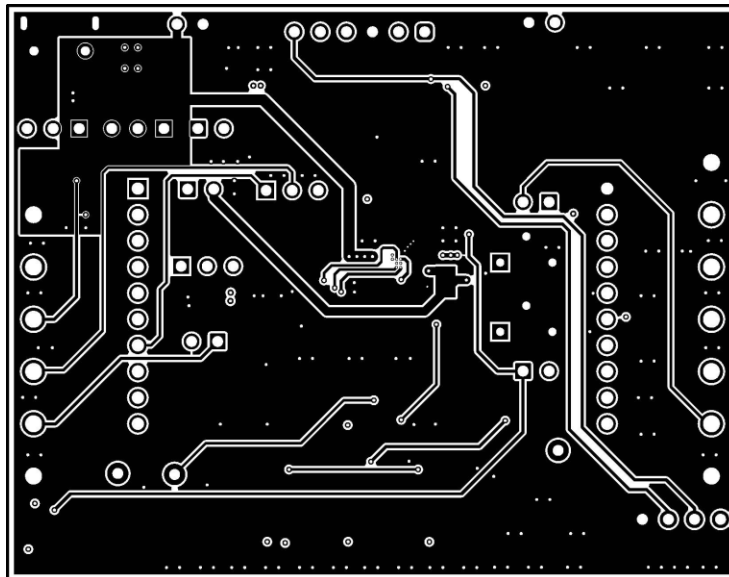

Figure 7. Signal Layer 2

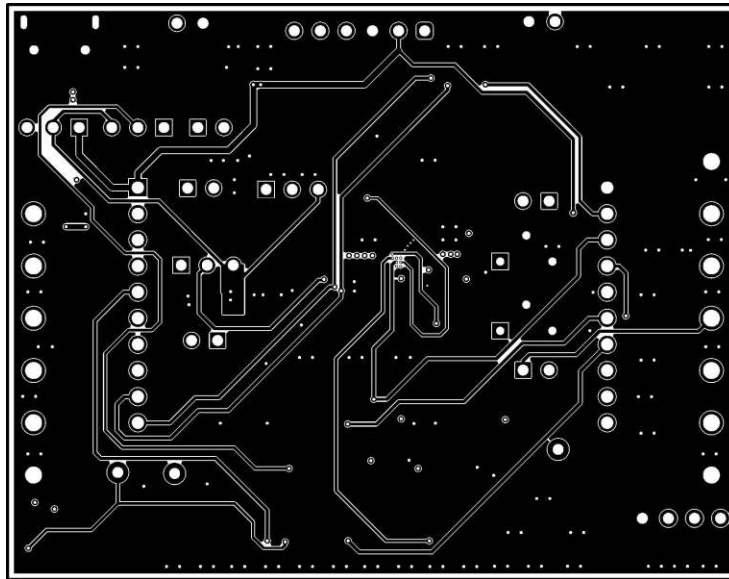

Figure 8. Bottom Layer

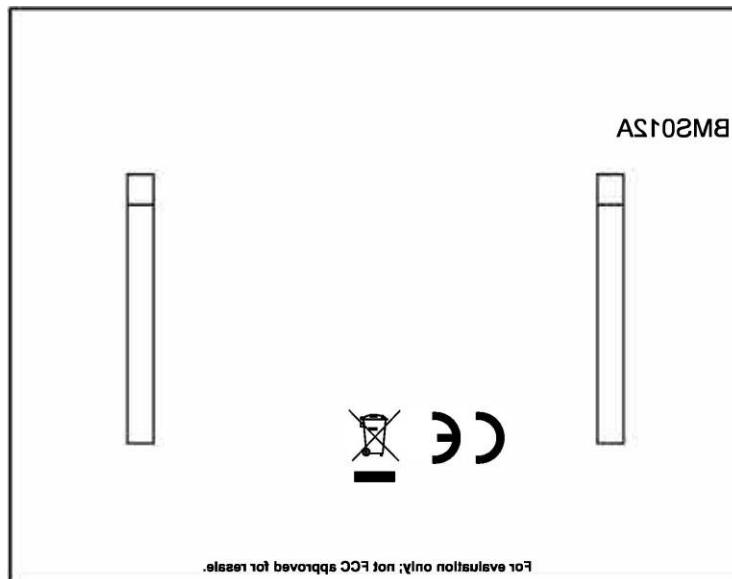

Figure 9. Bottom Overlay

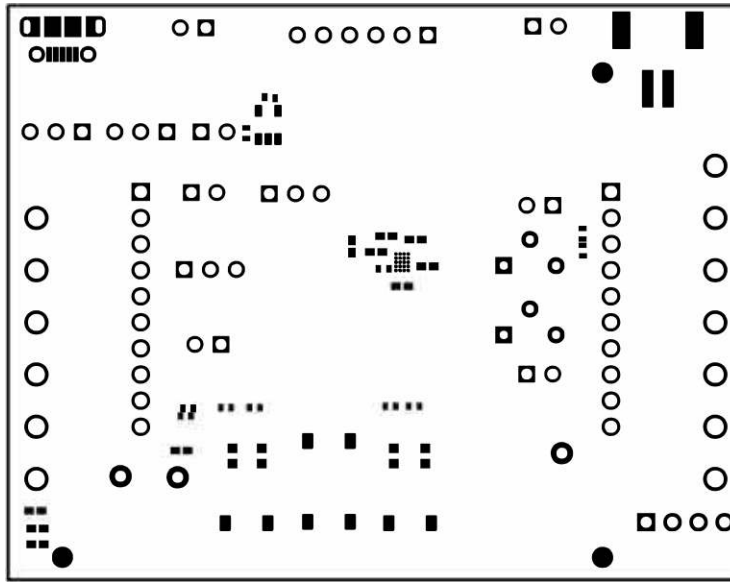

Figure 10. Top Solder Mask

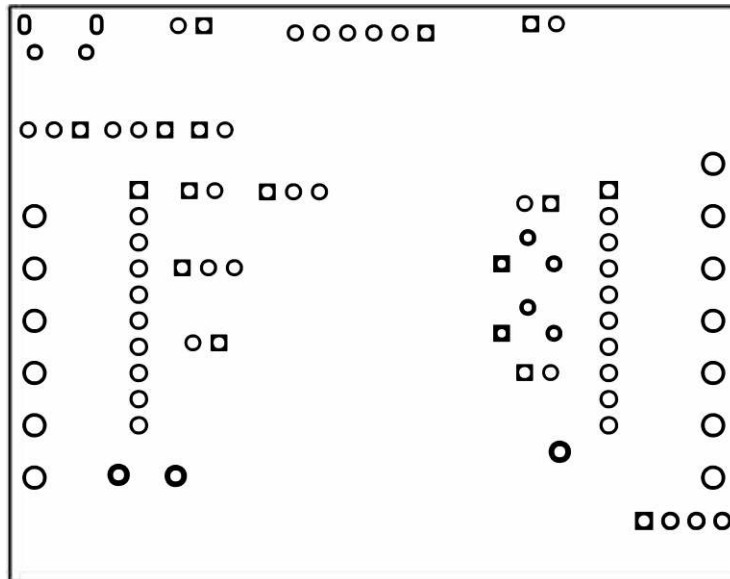

Figure 11. Bottom Solder Mask

Symbol	Count	Hole Size	Plated	Hole Type	Drill	Layer Pair	Uts/Pad	Pad Shape	Template	Description	Hole Tolerance (+)	Hole Tolerance (-)	Hole Length	Routed Path Length
⊕	2	23.42mil (0.920mm)	PTH	Slot		Top Layer - Bottom Layer	Pad	Rounded	r190_120x60_130x100				51.18mil (1.300mm)	27.56mil (0.700mm)
○	2	23.47mil (0.920mm)	PTH	Round		Top Layer - Bottom Layer	Pad	Rounded	c140x80				-	-
⊙	4	40.16mil (1.020mm)	PTH	Round		Top Layer - Bottom Layer	Pad	CHxvrd	CHxvrd				-	-
⊕	6	29.53mil (0.750mm)	PTH	Round		Top Layer - Bottom Layer	Pad	CHxvrd	CHxvrd				-	-
⊕	4	40.16mil (1.020mm)	PTH	Round		Top Layer - Bottom Layer	Pad	CHxvrd	CHxvrd				-	-
⊕	13	6.00mil (0.152mm)	PTH	Round		Top Layer - Bottom Layer	Uls	Rounded	CHxvrd		1.97mil (0.050mm)	1.97mil (0.050mm)	-	-
⊕	13	43.00mil (1.093mm)	PTH	Round		Top Layer - Bottom Layer	Pad	Rounded	c221x140				-	-
⊕	20	45.20mil (1.150mm)	PTH	Round		Top Layer - Bottom Layer	Pad	CHxvrd	CHxvrd				-	-
⊕	20	40.50mil (1.016mm)	PTH	Round		Top Layer - Bottom Layer	Pad	CHxvrd	CHxvrd				-	-
○	189	10.00mil (0.254mm)	PTH	Round		Top Layer - Bottom Layer	Uls	Rounded	CHxvrd				-	-
284 Total														

Slot definition: Routed Path Length = Calculated from tool start centre position to tool end centre position.
Hole Length = Routed Path Length + Tool Size + Slot length as defined in the PCB layout.

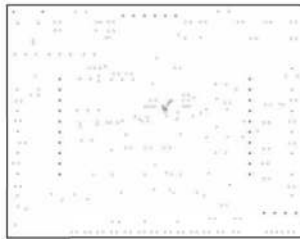

Figure 12. Drill Drawing



Figure 13. Board Dimensions

3.2 Schematics

Figure 14 and Figure 16 show the schematics for the BQ21061 EVM.

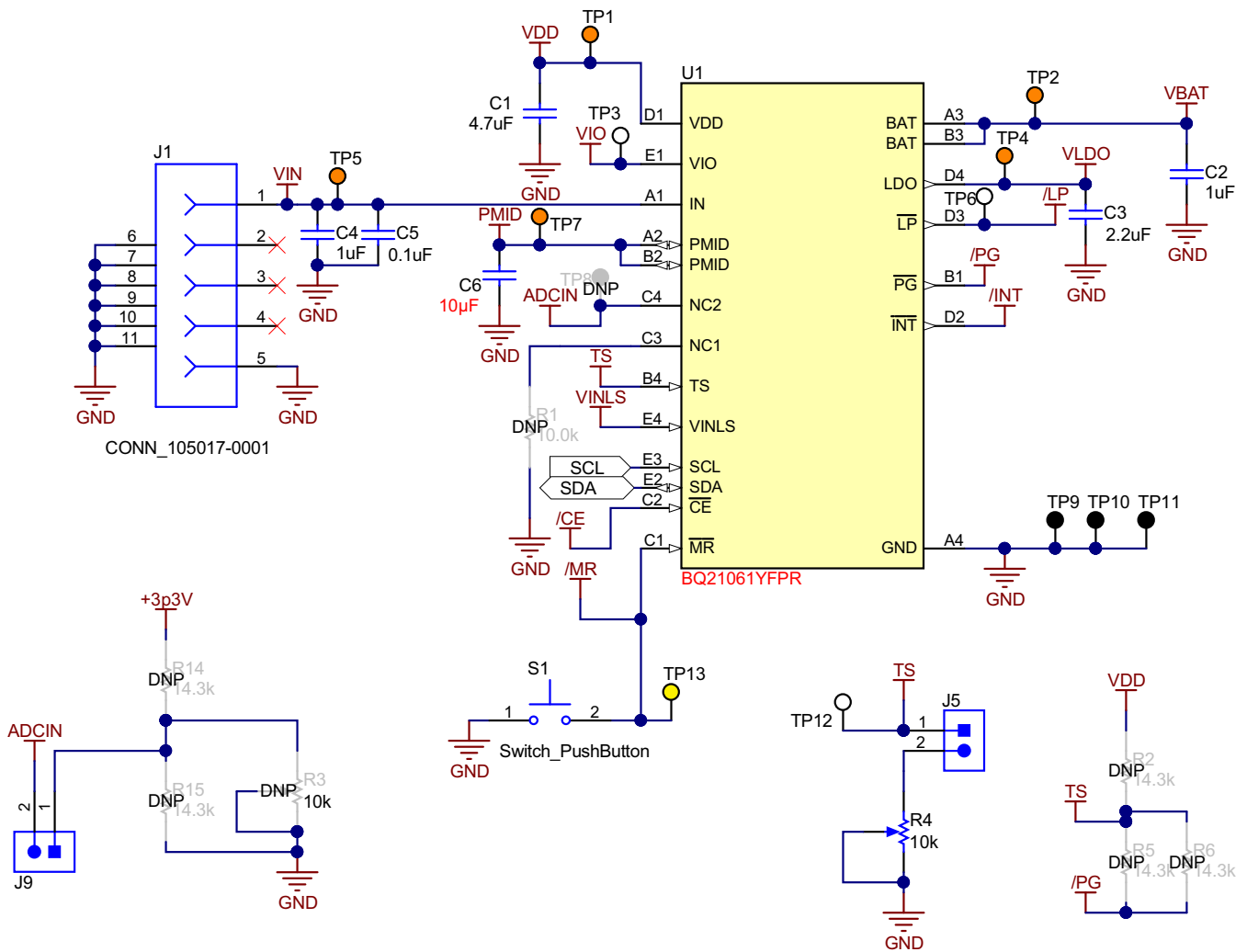

Figure 14. BQ21061 Low Iq Battery Charger with PowerPath Management Schematic

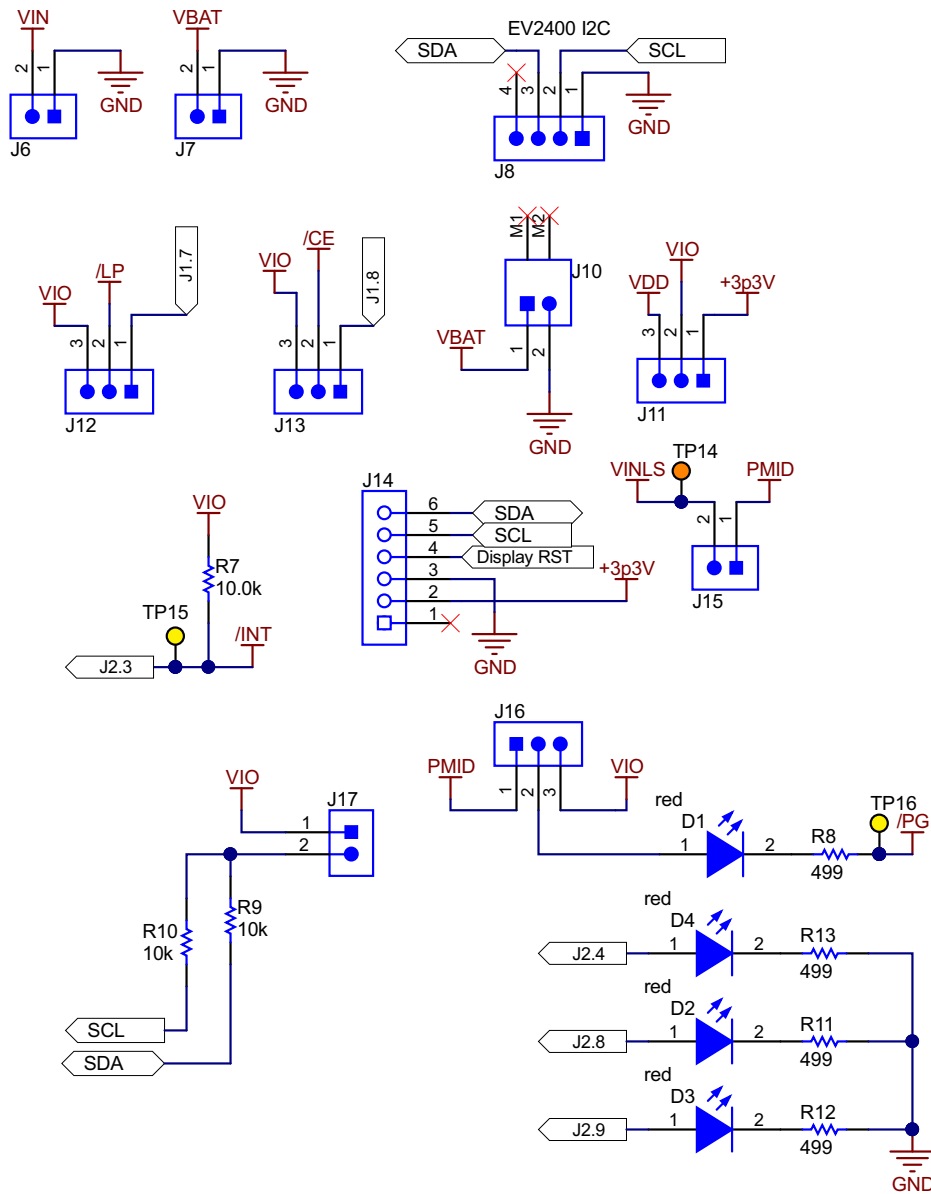

Figure 15. BQ21061EVM Jumper Connectors

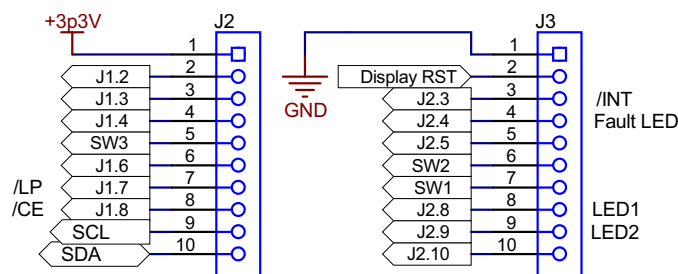

Figure 16. BQ21061EVM Interface Connector

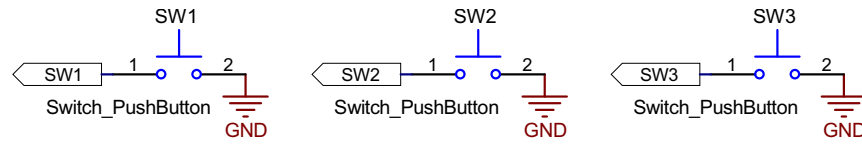

Figure 17. User Menu Switches

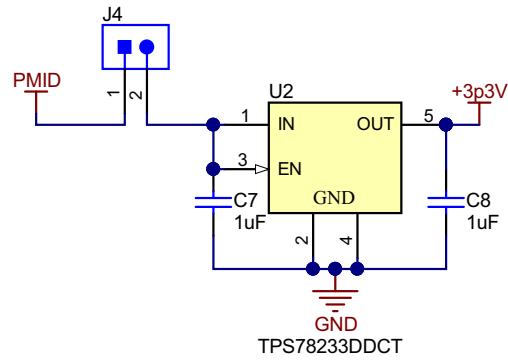

Figure 18. LDO for Display/Other Peripherals

3.3 Bill of Materials

The bill of materials is shown in the following table.

Table 5. Bill of Materials

Designator	Qty	Value	Description	Package Reference	Part Number	Manufacturer	Alternate Part Number ⁽¹⁾	Alternate Manufacturer ⁽¹⁾
C1	1	4.7uF	CAP, CERM, 4.7 uF, 10 V, +/- 20%, X5R, 0402	0402	GRM155R61A475 MEAAD	MuRata		
C2, C4, C7, C8	4	1uF	CAP, CERM, 1 uF, 25 V, +/- 10%, X5R, 0402	0402	C1005X5R1E105K 050BC	TDK		
C3	1	2.2uF	CAP, CERM, 2.2 uF, 10 V, +/- 10%, X7S, 0402	0402	C1005X7S1A225K 050BC	TDK		
C5	1	0.1uF	CAP, CERM, 0.1 uF, 25 V, +/- 10%, X7R, 0402	0402	GRM155R71E104 KE14D	MuRata		
C6	1	10uF	CAP, CERM, 10 uF, 10 V, +/- 20%, X5R, 0402	0402	0402ZD106MAT2A	AVX		
D1, D2, D3, D4	4	Red	LED, Red, SMD	Red LED, 1.6x0.8x0.8mm	LTST-C190CKT	Lite-On		
J1	1		Connector, Receptacle, Micro-USB Type B, R/A, Bottom Mount SMT	Micro USB receptacle	105017-0001	Molex		
J2, J3	2		Connector, Receptacle, 100mil, 10x1, Gold plated, TH	10x1 Receptacle	SSW-110-23-F-S	Samtec		
J4, J5, J6, J7, J9, J15, J17	7		Header, 100mil, 2x1, Tin, TH	Header, 2 PIN, 100mil, Tin	PEC02SAAN	Sullins Connector Solutions		
J8	1		Header (friction lock), 100mil, 4x1, R/A, TH	4x1 R/A Header	22/05/3041	Molex		
J10	1		Header (shrouded), 2mm, 2x1, R/A, SMT	Header, 2x1, 2mm, R/A	S2B-PH-SM4-TB(LF)(SN)	JST Manufacturing		
J11, J12, J13, J16	4		Header, 100mil, 3x1, Tin, TH	Header, 3 PIN, 100mil, Tin	PEC03SAAN	Sullins Connector Solutions		
J14	1		Receptacle, 2.54mm, 6x1, Gold, TH	Receptacle, 2.54mm, 6x1, Gold, TH	PPPC061LFBN-RC	Sullins Connector Solutions		
LBL1	1		Thermal Transfer Printable Labels, 0.650" W x 0.200" H - 10,000 per roll	PCB Label 0.650 x 0.200 inch	THT-14-423-10	Brady		
R4	1	10k ohm	Trimmer, 10k ohm, 0.25W, TH	4.5x8x6.7mm	3266W-1-103LF	Bourns		
R7	1	10.0k	RES, 10.0 k, 1%, 0.2 W, AEC-Q200 Grade 0, 0402	0402	ERJPA2F1002X	Panasonic		
R8, R11, R12, R13	4	499	RES, 499, 1%, 0.063 W, AEC-Q200 Grade 0, 0402	0402	CRCW0402499RF KED	Vishay-Dale		

⁽¹⁾ Unless otherwise noted in the Alternate PartNumber and/or Alternate Manufacturer columns, all parts may be substituted with equivalents.

Table 5. Bill of Materials (continued)

Designator	Qty	Value	Description	Package Reference	Part Number	Manufacturer	Alternate Part Number ⁽¹⁾	Alternate Manufacturer ⁽¹⁾
R9, R10	2	10k	RES, 10 k, 5%, 0.063 W, AEC-Q200 Grade 0, 0402	0402	CRCW040210K0J NED	Vishay-Dale		
S1, SW1, SW2, SW3	4		Switch, Tactile, SPST-NO, 0.05A, 12V, SMT	Switch, 4.4x2x2.9 mm	TL1015AF160QG	E-Switch		
SH-J1, SH-J2, SH-J3, SH-J4, SH-J5, SH-J6, SH-J7, SH-J8, SH-J9	9	1x2	Shunt, 100mil, Gold plated, Black	Shunt	SNT-100-BK-G	Samtec	969102-0000-DA	3M
TP1, TP2, TP4, TP5, TP7, TP14	6		Test Point, Multipurpose, Orange, TH	Orange Multipurpose Testpoint	5013	Keystone		
TP3, TP6, TP12	3		Test Point, Multipurpose, White, TH	White Multipurpose Testpoint	5012	Keystone		
TP9, TP10, TP11	3		Test Point, Multipurpose, Black, TH	Black Multipurpose Testpoint	5011	Keystone		
TP13, TP15, TP16	3		Test Point, Miniature, Yellow, TH	Yellow Miniature Testpoint	5004	Keystone		
U1	1		BQ21061YFPR, YFP0020ACAC (DSBGA-20)	YFP0020ACAC	BQ21061YFPR	Texas Instruments		Texas Instruments
U2	1		Single Output LDO, 150 mA, Fixed 3.3 V Output, 2.2 to 5.5 V Input, with 0.5 uA Quiescent Current, 5-pin SOT (DDC), -40 to 125 degC, Green (RoHS and no Sb/Br)	DDC0005A	TPS78233DDCT	Texas Instruments		
FID1, FID2, FID3	0		Fiducial mark. There is nothing to buy or mount.	N/A	N/A	N/A		
R1	0	10.0k	RES, 10.0 k, 1%, 0.2 W, AEC-Q200 Grade 0, 0402	0402	ERJPA2F1002X	Panasonic		
R2, R5, R6, R14, R15	0	14.3k	RES, 14.3 k, 1%, 0.063 W, AEC-Q200 Grade 0, 0402	0402	CRCW040214K3F KED	Vishay-Dale		
R3	0	10k ohm	Trimmer, 10k ohm, 0.25W, TH	4.5x8x6.7mm	3266W-1-103LF	Bourns		
TP8	0		Test Point, Multipurpose, White, TH	White Multipurpose Testpoint	5012	Keystone		

IMPORTANT NOTICE AND DISCLAIMER

TI PROVIDES TECHNICAL AND RELIABILITY DATA (INCLUDING DATASHEETS), DESIGN RESOURCES (INCLUDING REFERENCE DESIGNS), APPLICATION OR OTHER DESIGN ADVICE, WEB TOOLS, SAFETY INFORMATION, AND OTHER RESOURCES “AS IS” AND WITH ALL FAULTS, AND DISCLAIMS ALL WARRANTIES, EXPRESS AND IMPLIED, INCLUDING WITHOUT LIMITATION ANY IMPLIED WARRANTIES OF MERCHANTABILITY, FITNESS FOR A PARTICULAR PURPOSE OR NON-INFRINGEMENT OF THIRD PARTY INTELLECTUAL PROPERTY RIGHTS.

These resources are intended for skilled developers designing with TI products. You are solely responsible for (1) selecting the appropriate TI products for your application, (2) designing, validating and testing your application, and (3) ensuring your application meets applicable standards, and any other safety, security, or other requirements. These resources are subject to change without notice. TI grants you permission to use these resources only for development of an application that uses the TI products described in the resource. Other reproduction and display of these resources is prohibited. No license is granted to any other TI intellectual property right or to any third party intellectual property right. TI disclaims responsibility for, and you will fully indemnify TI and its representatives against, any claims, damages, costs, losses, and liabilities arising out of your use of these resources.

TI's products are provided subject to TI's Terms of Sale (www.ti.com/legal/termsofsale.html) or other applicable terms available either on ti.com or provided in conjunction with such TI products. TI's provision of these resources does not expand or otherwise alter TI's applicable warranties or warranty disclaimers for TI products.

Mailing Address: Texas Instruments, Post Office Box 655303, Dallas, Texas 75265
Copyright © 2019, Texas Instruments Incorporated

IMPORTANT NOTICE AND DISCLAIMER

TI PROVIDES TECHNICAL AND RELIABILITY DATA (INCLUDING DATA SHEETS), DESIGN RESOURCES (INCLUDING REFERENCE DESIGNS), APPLICATION OR OTHER DESIGN ADVICE, WEB TOOLS, SAFETY INFORMATION, AND OTHER RESOURCES "AS IS" AND WITH ALL FAULTS, AND DISCLAIMS ALL WARRANTIES, EXPRESS AND IMPLIED, INCLUDING WITHOUT LIMITATION ANY IMPLIED WARRANTIES OF MERCHANTABILITY, FITNESS FOR A PARTICULAR PURPOSE OR NON-INFRINGEMENT OF THIRD PARTY INTELLECTUAL PROPERTY RIGHTS.

These resources are intended for skilled developers designing with TI products. You are solely responsible for (1) selecting the appropriate TI products for your application, (2) designing, validating and testing your application, and (3) ensuring your application meets applicable standards, and any other safety, security, regulatory or other requirements.

These resources are subject to change without notice. TI grants you permission to use these resources only for development of an application that uses the TI products described in the resource. Other reproduction and display of these resources is prohibited. No license is granted to any other TI intellectual property right or to any third party intellectual property right. TI disclaims responsibility for, and you will fully indemnify TI and its representatives against, any claims, damages, costs, losses, and liabilities arising out of your use of these resources.

TI's products are provided subject to [TI's Terms of Sale](#) or other applicable terms available either on ti.com or provided in conjunction with such TI products. TI's provision of these resources does not expand or otherwise alter TI's applicable warranties or warranty disclaimers for TI products.

TI objects to and rejects any additional or different terms you may have proposed.

Mailing Address: Texas Instruments, Post Office Box 655303, Dallas, Texas 75265
Copyright © 2022, Texas Instruments Incorporated