

NOTES:

1. MATERIALS: HOUSING - LIQUID CRYSTAL POLYMER (LCP), BLACK, UL94V-0
TERMINALS - HIGH PERFORMANCE COPPER ALLOY
2. FINISH: SELECTIVE GOLD IN CONTACT AREA.
SELECTIVE MATTE TIN ON PCB TAILS. NICKEL OVERALL.
3. MOLEX PRODUCT SPECIFICATION: PS-75710-999.
4. OPTIONAL GUIDE PIN SHOWN IN COPLANAR LOCATION.
5. PACKAGED PER PK-70873-585.
6. THIS PART CONFORMS TO CLASS B REQUIREMENTS OF MOLEX COSMETIC SPEC PS-45499-002.
7. GUIDED PARTS TO BE SHIPPED WITH 2-32 TYPE AB SELF-TAPPING SCREW P/N 73726-0000.
8. MAPS (MOLEX ADVANCED PLATING SYSTEM).

MATERIAL NUMBER	# OF COLUMNS	DIM "A" MAX	DIM "B"
75910-*5**	5	25.9	14.80
75910-*6**	6	29.6	18.50
75910-*1**	10	44.4	33.30

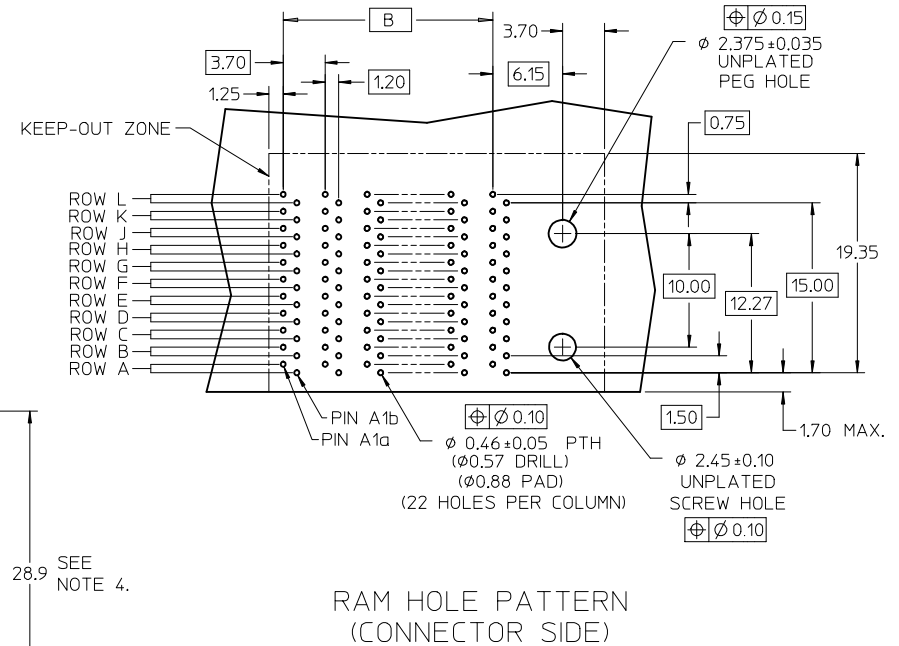
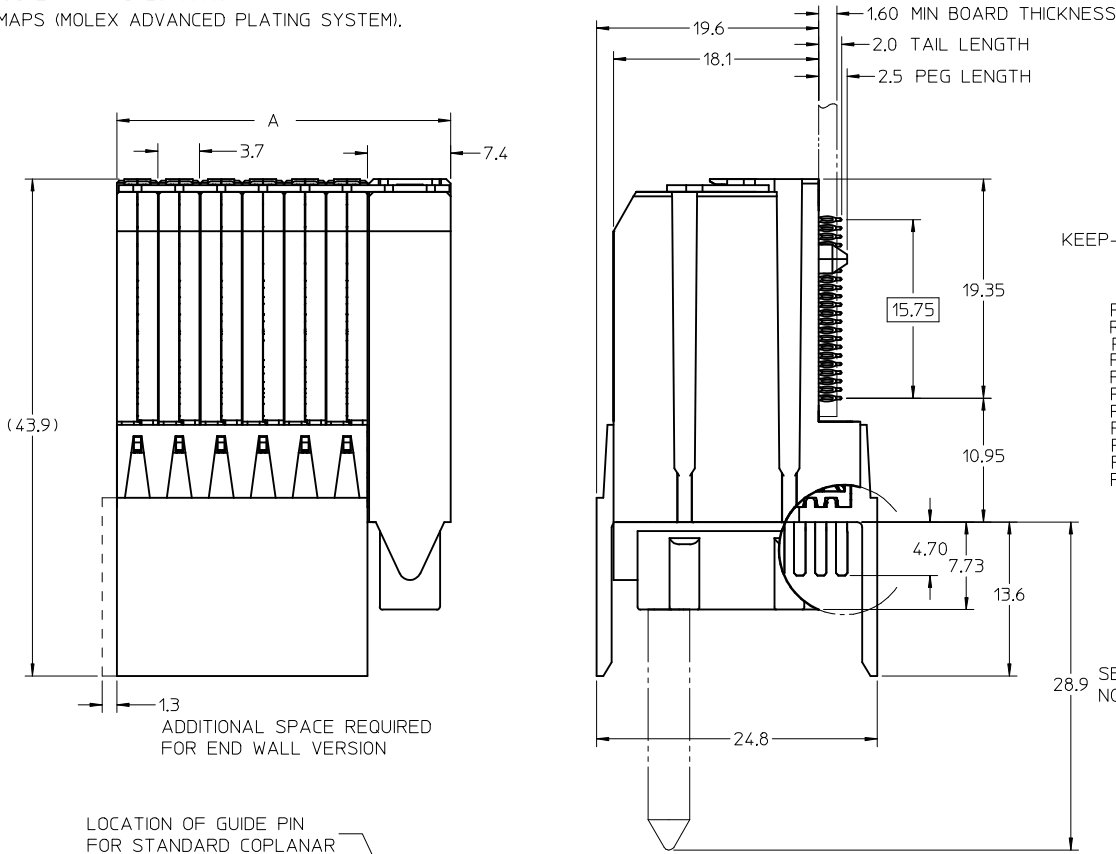

LOCATION OF GUIDE PIN FOR STANDARD COPLANAR

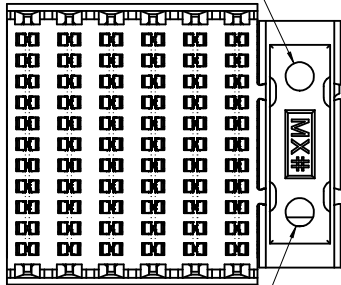

LOCATION OF GUIDE PIN FOR INVERTED APPLICATION

(75910-***3)
(75910-***7)

LEAD FREE CON/ MAPS EC NO: UCP2013-4121 DRWNR:WHIPPLE 2013/04/01 CHKD:MWOLFE 2013/04/01 APPR:SMILLER 2013/07/15	QUALITY SYMBOLS ▽=0 ▽=0 ▽=0	GENERAL TOLERANCES (UNLESS SPECIFIED)		DIMENSION STYLE MM ONLY		SCALE 3:1	DESIGN UNITS METRIC	THIRD ANGLE PROJECTION			
		4 PLACES ± --- ± --- 3 PLACES ± --- ± --- 2 PLACES ± 0.13 ± --- 1 PLACE ± 0.25 ± --- 0 PLACE ± ±	mm INCH ± --- ± --- ± 0.13 ± --- ± 0.25 ± --- ± ±	DRAWN BY ELO	DATE 2006/06/19	CHECKED BY ELO	DATE 2006/11/09	TITLE I-TRAC 11 ROW RAM ASS'Y DIFFERENTIAL LONG NOSE GUIDE RIGHT			
DRAFT WHERE APPLICABLE MUST REMAIN WITHIN DIMENSIONS		ANGULAR ±1/2°		APPROVED BY BIXLER		DATE 2006/11/10	DOCUMENT NO. SD-75910-003		SHEET NO. 1 OF 3		
REV G		SIZE C		MATERIAL NO. SEE CHART						THIS DRAWING CONTAINS INFORMATION THAT IS PROPRIETARY TO MOLEX INCORPORATED AND SHOULD NOT BE USED WITHOUT WRITTEN PERMISSION	

75910-****

MODULE TYPE - TAIL PLATING TYPE
 GUIDE RIGHT - MATTE TIN (FORMERLY TIN/LEAD) = 4
 GUIDE RIGHT - MATTE TIN = 5
 GUIDE RIGHT, END WALL - MATTE TIN (FORMERLY TIN/LEAD) = 8
 GUIDE RIGHT, END WALL - MATTE TIN = 9

OF COLUMNS
 5 = 5 COL
 6 = 6 COL
 1 = 10 COL

PIN LENGTH/PLATING
 3 = 4.70 30 GOLD
 5 = 6 X 3.80, 5 X 4.70 STAGGERED 30 GOLD
 6 = 2 X 3.80, 9 X 4.70 STAGGERED 30 GOLD
 7 = 4.70 10 GOLD (MAPS)
 8 = 6 X 3.80, 5 X 4.70 STAGGERED 10 GOLD (MAPS)
 9 = 2 X 3.80, 9 X 4.70 STAGGERED 10 GOLD (MAPS)

ORIENTATION OF GUIDE POST
 2 = COPLANAR
 3 = INVERTED

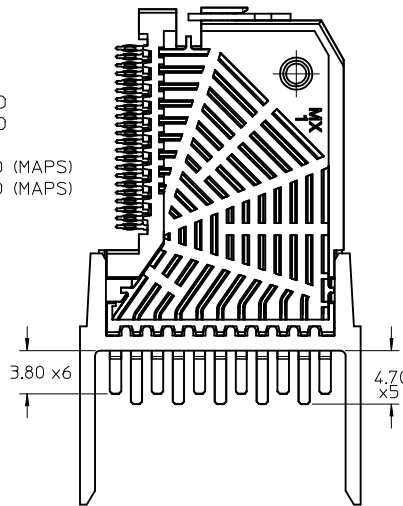

STAGGERED PIN OPTION
 (75910-***5)
 (75910-***8)

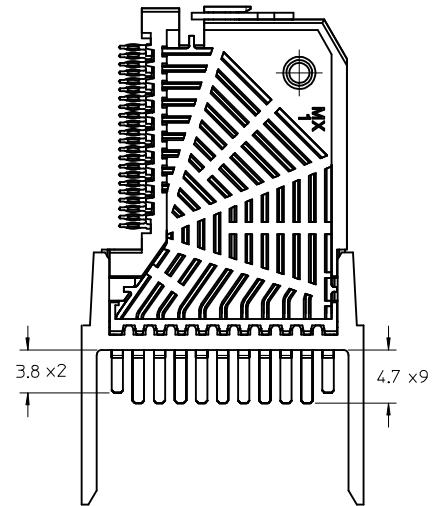

STAGGERED PIN OPTION
 (75910-***6)
 (75910-***9)

NOTE:

WHEN MATING RIGHT ANGLE MALE (RAM) TO A DAUGHTERCARD IN A COPLANAR APPLICATION, THE GUIDE CONFIGURATION IS OPPOSING (DC GUIDE LEFT MATED TO RAM GUIDE RIGHT). WHEN INVERTED, THE RAM AND DAUGHTERCARD HAVE THE SAME GUIDE CONFIGURATION (DC GUIDE RIGHT MATED TO RAM GUIDE RIGHT). (SEE SHEET 3)

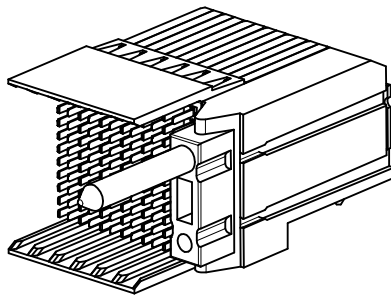
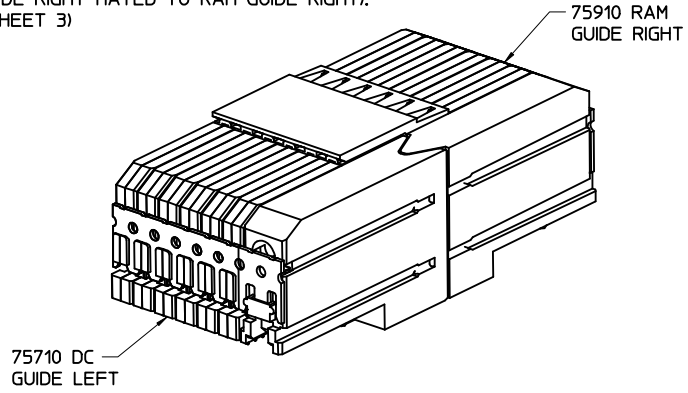

75910-4*2* or
 75910-5*2*
 GUIDE RIGHT, COPLANAR

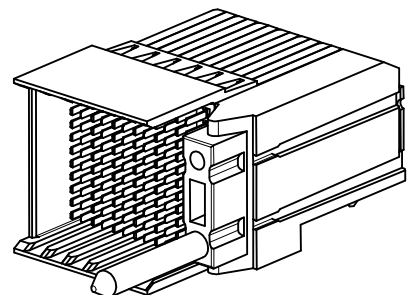

75910-8*3* or
 75910-9*3*
 GUIDE RIGHT, END WALL, INVERTED

SEE SHEET 1 EC NO: UCP2013-4121 DRW:RWHIPPLE 2013/04/01 CHK:DHWOLFE 2013/04/01 APPR:SMILLER 2013/07/15	QUALITY SYMBOLS ▽=0 ▽=0 ▽=0	GENERAL TOLERANCES (UNLESS SPECIFIED) mm INCH 4 PLACES ± --- ± --- 3 PLACES ± --- ± --- 2 PLACES ± 0.13 ± --- 1 PLACE ± 0.25 ± --- 0 PLACE ± ±	DIMENSION STYLE MM ONLY DRAWN BY DATE ELO 2006/06/19 CHECKED BY DATE ELO 2006/11/09 APPROVED BY DATE BIXLER 2006/11/10	SCALE 2:1 DESIGN UNITS METRIC THIRD ANGLE PROJECTION	TITLE I-TRAC 11 ROW RAM ASS'Y DIFFERENTIAL LONG NOSE GUIDE RIGHT molex	MATERIAL NO. SEE CHART DOCUMENT NO. SD-75910-003 SHEET NO. 2 OF 3
	DRAFT WHERE APPLICABLE MUST REMAIN WITHIN DIMENSIONS	ANGULAR ±1/2°	THIS DRAWING CONTAINS INFORMATION THAT IS PROPRIETARY TO MOLEX INCORPORATED AND SHOULD NOT BE USED WITHOUT WRITTEN PERMISSION			

COPLANAR APPLICATION

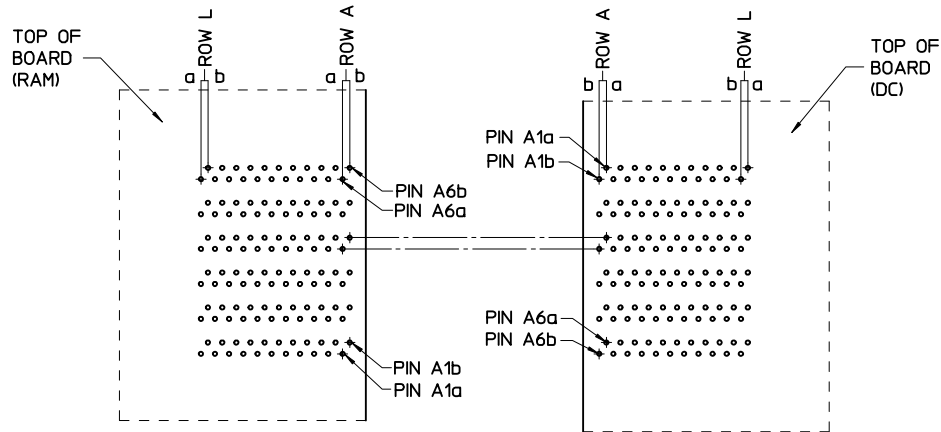
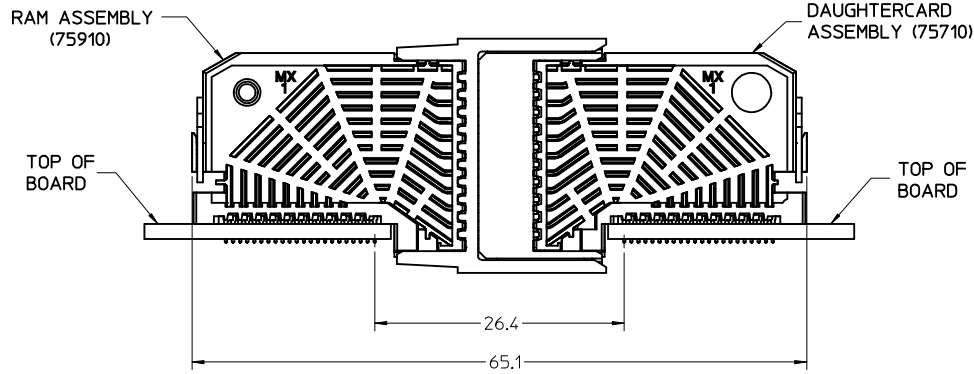

COPLANAR MATED SIGNAL PATHS

RAM PIN A6b	DC PIN A1a
RAM PIN A6a	DC PIN A1b
.....
RAM PIN A1b	DC PIN A6a
RAM PIN A1a	DC PIN A6b

INVERTED APPLICATION

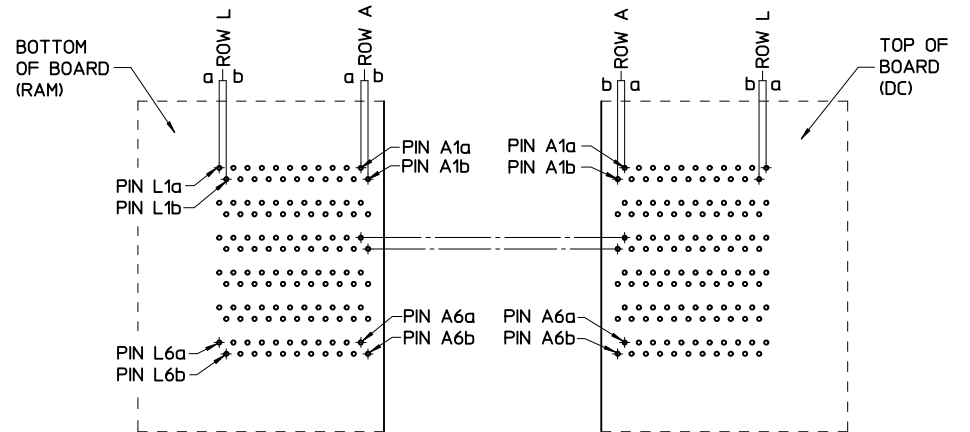
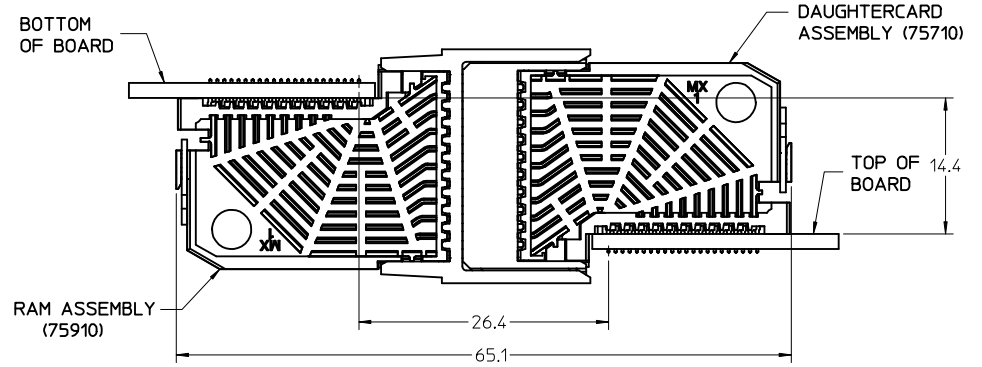

INVERTED MATED SIGNAL PATHS

RAM PIN L1a	DC PIN A1a
RAM PIN L1b	DC PIN A1b
.....
RAM PIN L6a	DC PIN A6a
RAM PIN L6b	DC PIN A6b

SEE SHEET 1 EC NO: UCP2013-4121 DRW:RWHIPPLE 2013/04/01 CHKD:MWOLFE 2013/04/01 APPR:SMILLER 2013/07/15	QUALITY SYMBOLS	GENERAL TOLERANCES (UNLESS SPECIFIED)	DIMENSION STYLE MM ONLY	SCALE 2:1	DESIGN UNITS METRIC	THIRD ANGLE PROJECTION
	▽=0	mm INCH	DRAWN BY DATE ELO 2006/06/19	TITLE I-TRAC 11 ROW RAM ASS'Y DIFFERENTIAL LONG NOSE GUIDE RIGHT	molex DOCUMENT NO. SD-75910-003	SHEET NO. 3 OF 3
	▽=0	4 PLACES ± --- ± ---	CHECKED BY DATE ELO 2006/11/09			
	▽=0	3 PLACES ± --- ± ---	APPROVED BY DATE BIXLER 2006/11/10			
▽=0	2 PLACES ± 0.13 ± ---	MATERIAL NO.				
		1 PLACE ± 0.25 ± ---	SEE CHART	THIS DRAWING CONTAINS INFORMATION THAT IS PROPRIETARY TO MOLEX INCORPORATED AND SHOULD NOT BE USED WITHOUT WRITTEN PERMISSION		
		0 PLACE ± ±	SIZE C			
		ANGULAR ±1/2°				
		DRAFT WHERE APPLICABLE MUST REMAIN WITHIN DIMENSIONS				