



GlobalTech Display

A Professional LCD Displays Provider

TFT LCD Display Specification

PN: GLT035320480IR3

Overview:

- 3.5" Diagonal
- IPS, Full View Angle
- Driver: ILI9488
- 65K/262K Colors
- 450 Nits
- 320 x 480 Pixels
- Transmissive/Normally Black
- 8-bit MCU Interface
- No Touch Panel
- RoHS Compliant

9825 Widmer Road, Lenexa, KS 66215, USA | Tel: 913-828-5685 Fax: 913-273-4397

Email: sales@gtdisplays.com Website: www.gtdisplays.com

Table of Contents

1. Record of Revision.....	2
2. General Specifications.....	3
3. Input / Output Terminals.....	4
4. Absolute Maximum Rating.....	4
5. Electrical Characteristics.....	5
6. Interface Timing.....	6
7. Optical Characteristics.....	10
8. Environmental / Reliability Tests.....	13
9. Mechanical Drawing.....	14
10. Packing.....	15
11. TFT-LCD Module Inspection Criteria.....	16
12. Precautions for Use of LCD modules.....	20

2. General Specifications

Feature		Spec
Characteristics	Size	3.5 inch
	Resolution	320(horizontal) x 480(Vertical)
	Interface	8-bit MCU
	Connect type	Connector
	Display Colors	65K/262K
	Pixel pitch (mm)	0.153 x 0.153
	Pixel Configuration	RGB Stripe
	Display Mode	Normally black
	LCD Driver IC	ILI9488
	Viewing Direction	Full view
Mechanical	LCM (W x H x D) (mm)	54.76 x 83.58 x 3.0
	Active Area(mm)	48.96 x 73.44
	With or without TSP	No
	Weight (g)	~30g
	LED Numbers	6 LEDS

Note 1: Requirements on Environmental Protection: RoHs

Note 2: LCM weight tolerance: +/- 5%

3. Input / Output Terminals

No.	Symbol	Description
1	VCI	A supply voltage to the analog circuit
2	IOVCC	A supply voltage to the digital circuit
3	DGND	System Ground
4	RESX	Reset signal.
5	CSX	Chip select input signal
6	D/CX	Data/Command Selection pin
7	WRX/SCL	SCL pin as Serial Clock.
8	RDX	serve as a read signal
9	DGND	System Ground
10	DB0	Data bus
11	DB1	Data bus
12	DB2	Data bus
13	DB3	Data bus
14	DB4	Data bus
15	DB5	Data bus
16	DB6	Data bus
17	DB7	Data bus
18	DGND	System Ground
19	LEDA	Backlight LED Anode
20	LEDK1	Backlight LED Cathode
21	LEDK2	Backlight LED Cathode
22	LEDK3	Backlight LED Cathode
23	LEDK4	Backlight LED Cathode
24	LEDK5	Backlight LED Cathode
25	LEDK6	Backlight LED Cathode
26	DGND	System Ground

4. Absolute Maximum Rating

Item	Symbol	MIN.	MAX.	Unit	Note
Analog Supply voltage	VDD	-0.3	5.0	V	Note 1
Digital supply voltage	IOVCC	-0.3	3.6	V	Note 1

Note 1: Permanent damage may occur to the LCD module if beyond this specification.

Functional operation should be restricted to the conditions described under normal operating conditions.

5. Timing characteristics

5.1 Recommended Operating Condition for TFT LCD

Item	Symbol	Min.	Typ.	Max.	Unit	Note
Analog Supply voltage	V _{CI}	3.0	3.3	3.6	V	
Analog supply current	I _{VCI}	-	TBD	-	mA	V _{CI} =3.3V
Logic supply voltage	IOVCC	1.65	1.8	3.3	V	
Logic supply current	I _{IOVCC}	-	TBD	-	mA	IOVCC=1.8V
Logic input voltage	V _{IH}	0.7*IOVCC	-	IOVCC	V	
	V _{IL}	GND	-	0.3*IOVCC	V	

5.2 Recommended Driving Condition for Backlight

Item	Symbol	Min.	Typ.	Max.	Unit	Note
Driving Current	I _F	-	120	-	mA	
Driving Voltage	V _F	2.7	-	3.4	V	
Power consumption	W _{BL}	0.324	-	0.408	W	
LED Life-Time	N/A	30,000	50,000	-	Hours	Ta=25°C Note 1

Note 1: LED lifetime is defined as the module brightness decay 50% of original brightness at Ta=25 degree, typical current.

Note 2: LED circuit:

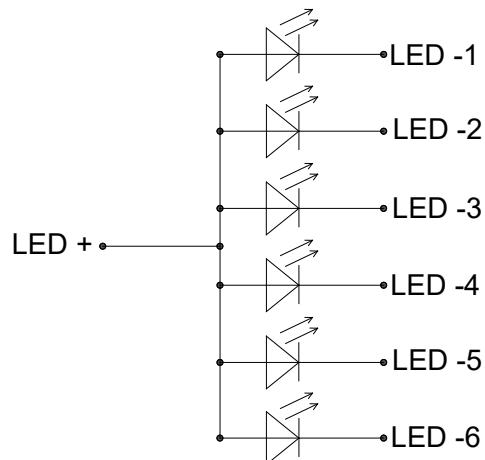

6. Interface Characteristics

6.1 DC Characteristics for Panel Driving

Item	Symbol	Condition	Min.	Typ.	Max.	Unit	Note
Power & Operation Voltage							
Analog operating voltage	VCI	-	2.5	2.8	3.3	V	
Logic operating voltage	IOVCC	-	1.65	1.8	3.3	V	Note 1, 2
OTP Supply voltage	DDVDH	-	-	7	-	V	Note 1
Logic High level input voltage	VIH	-	0.7*IOVCC		IOVCC	V	Note 1
Logic Low level input voltage	VIL	-	-0.3		0.3*IOVCC	V	Note 1
Logic High level output voltage TE, SDO (SDA) , CABC_PWM_OUT	VOH	IOH = -1.0mA	0.8*IOVCC		IOVCC	V	Note 1
Logic Low level output voltage TE, SDO (SDA) , CABC_PWM_OUT	VoL	IOL = +1.0mA	0		0.2*IOVCC	V	Note 1
Gate Driver High Voltage	VGH	-	10.0	-	20	V	
Gate Driver Low Voltage	VGL	-	-15.0	-	-6.0	V	
Driver Supply Voltage	-	VGH-VGL	16	-	32	V	
Input and Output							
Logic High Level Input Voltage	VIH	-	0.7*IOVCC	-	IOVCC	V	
Logic Low Level Input Voltage	VIL	-	DGND	-	0.3*IOVCC	V	
VCOM Operation							
DC VCOM Amplitude Voltage	VCOM	-	-2.0	-	-0.06	V	Note 3
Source Driver							
Source Output Range	VsOUT	-	0.1	-	VREG1OUT-0.1	V	Note 4
Positive Gamma Reference Voltage	VREG1OUT	-	3.625	-	5.5	V	
Negative Gamma Reference Voltage	VREG2OUT	-	-5.5	-	-3.625	V	
Source Output Setting Time	Tr	Below with 99% precision	-	10	-	uS	Note 3, 4
Output Deviation Voltage (Source Output channel)	Vdev	Sout<=4.2V Sout<=0.8V	-	-	20	mV	Note 3
		4.2V>Sout>0.8V	-	-	15	mV	-
Output Offset Voltage	VOFFSET	-	-	-	35	mV	Note 3
Booster Operation							
Booster (VCIx2) Voltage	DDVDH	-			6	V	
Booster (VCIx2) Voltage	DDVDL	-	-6			V	
Booster (VCIx2 Drop Voltage)	VCI1x2 drop	loading=1mA	-	-	5	%	
Gate Driver High Voltage	VGH	-	10.0	-	20	V	
Gate Driver Low Voltage	VGL	-	-15.0	-	-6.0	V	
Standby mode current consumption (Ta = 25 °C, Interface: DBI and DPI)							
Sleep in mode	VCI	VCI=2.8V	-	100	-	uA	
Deep Standby mode	VCI	IOVCC=1.8V	-	1	-	uA	

Notes:

1. Ta = -30 to 70 °C (no damage up to 85°C (at maximum)), IOVCC=1.65V to 3.3V, VCI=2.5V to 3.3V, DGND=0V.
2. Supply the digital IOVCC voltage equal to or less than the analog VCI voltage.
3. Source channel loading = 10KΩ,30pF/channel
4. The maximum value is between 10KΩ,30pF/channel and Gamma setting value.

6.2 8-bit Parallel MCU Interface

The DBI TYPE B 8-bit parallel bus interface of the ILI9488 is used by setting the external pin IM [2:0] as 011. Figure 109 shows this system interface.

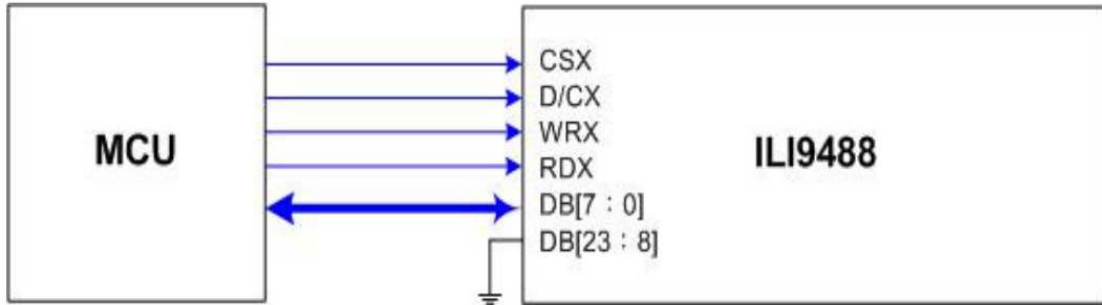

Figure 109: 8-bit Parallel MCU Interface

The available display data formats are:

- 65K-Colors, RGB 5, 6, 5 bits input data (set Standard Command 3Ah, DBI [2:0] as 101)
- 262K-Colors, RGB 6, 6, 6 bits input data (set Standard Command 3Ah, DBI [2:0] as 110)

8-bit Data Bus for 16-bit/pixel (RGB 5-6-5 Bits Input), 65K-color

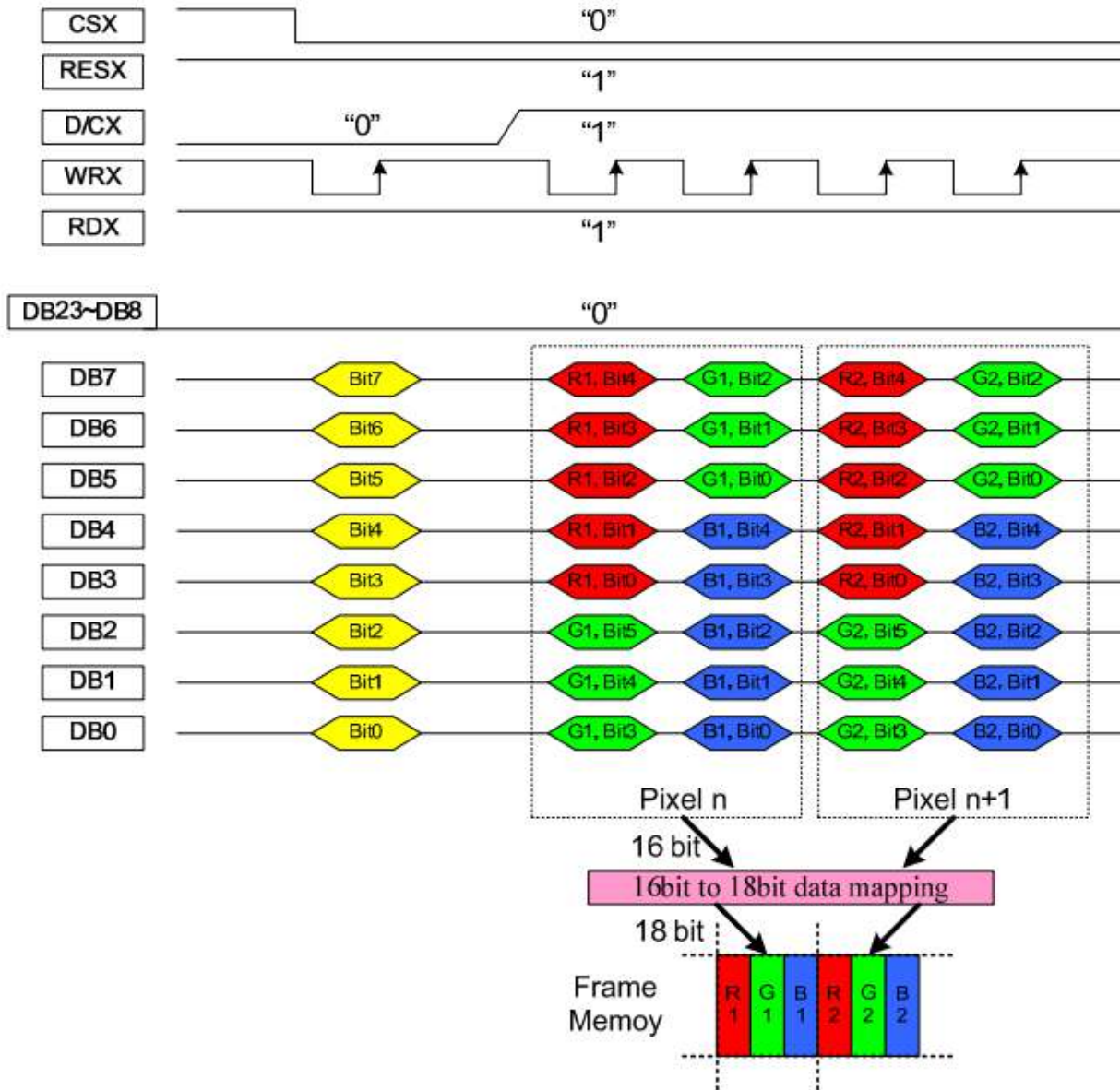

Figure 110: 8-bit Data Bus for 16-bit/pixel (RGB 6-5-6 Bits Input), 65K-color

Notes:

1. The data order is as follows: MSB = DB7, LSB = DB0, and picture data is MSB = Bit 5, LSB = Bit 0 for Green data, and MSB = Bit 4, LSB = Bit 0 for Red and Blue data.
2. 2-times transfer is used to transmit 1 pixel data to the 16-bit color depth information.
3. '-' = void

8-bit Data Bus for 18-bit/pixel (RGB 6-6-6 Bits Input), 262K-color

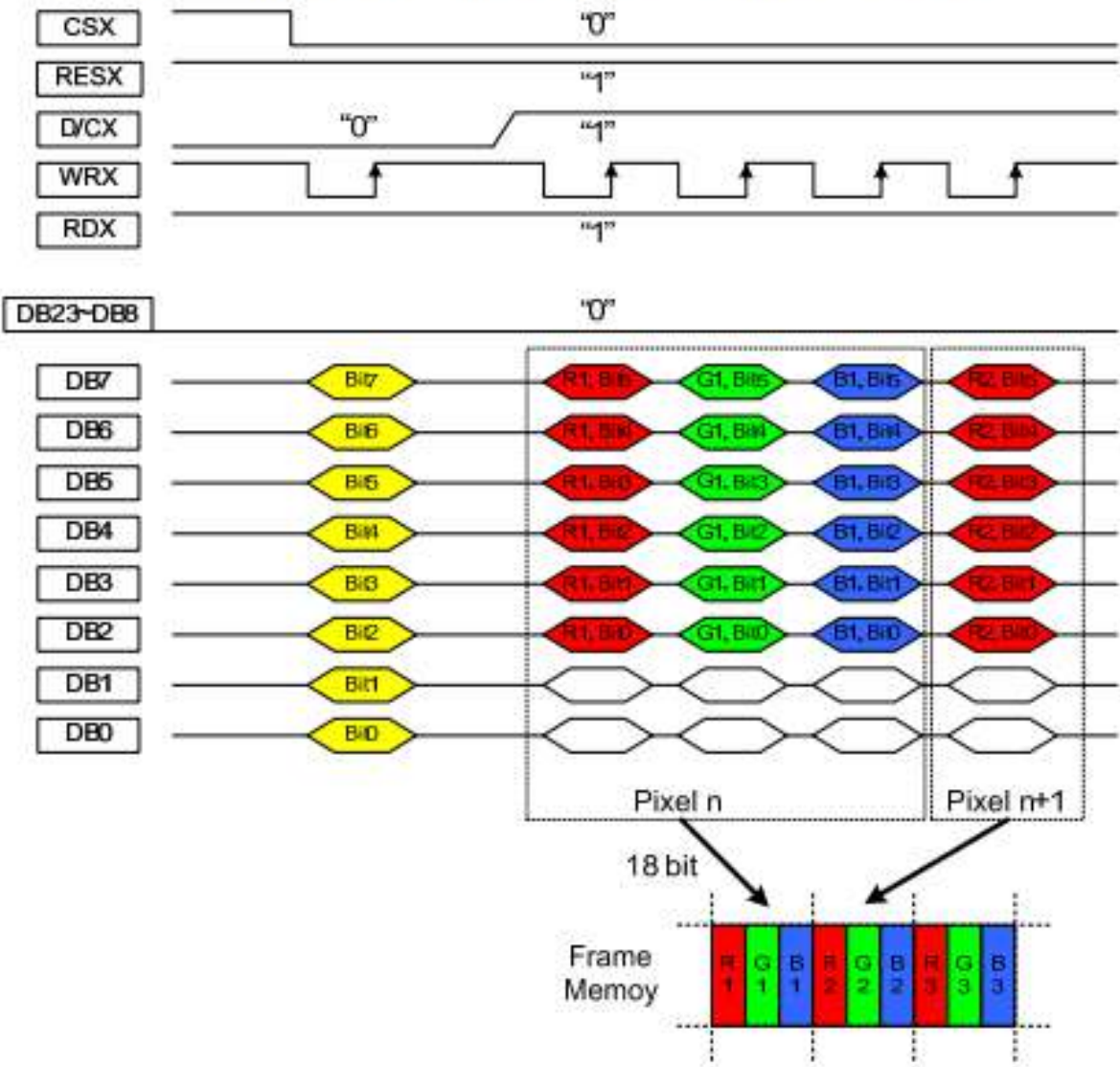

Figure 111: 8-bit Data Bus for 18-bit/pixel (RGB 6-6-6 Bits Input), 262K-color

Notes:

1. The data order is as follows: MSB = DB7, LSB = DB0, and picture data is MSB = Bit 5, LSB = Bit 0 for Green, Red and Blue data.
2. 3-times transfer is used to transmit 1 pixel data to the 18-bit color depth information.
3. '-' = void

7. Optical Specifications

Item	Symbol	Condition	Min.	Typ.	Max.	Unit	Note
Viewing Angle (CR≥10) B/L ON	θ_T	$\Phi=90^\circ$ (12 o'clock)	70	80	-	deg	Note2
	θ_B	$\Phi=270^\circ$ (6 o'clock)	70	80	-	deg	Note2
	θ_L	$\Phi=180^\circ$ (9 o'clock)	70	80	-	deg	Note2
	θ_R	$\Phi=0^\circ$ (3 o'clock)	70	80	-	deg	Note2
Response Time	T_{ON}	Normal $\theta=\Phi=0^\circ$	-	15	-	msec	Note4
	T_{OFF}		-	15	-	msec	Note4
Contrast Ratio	CR		-	700	-	-	Note1 Note3
Color Chromaticity	W_X		0.2746	0.3246	0.3746	-	Note1 Note5
	W_Y		0.2984	0.3484	0.3984	-	Note1 Note5
Luminance	L		400	450	-	cd/m ²	Note1 Note7
Luminance Uniformity	Y_U		75	80	-	%	Note1 Note6
NTSC	-		-	50	-	%	-

Note 1: Definition of optical measurement system

The optical characteristics should be measured in dark room. After 5 minutes operation, the optical properties are measured at the center point of the LCD screen. All input terminals LCD panel must be ground when measuring the center area of the panel.

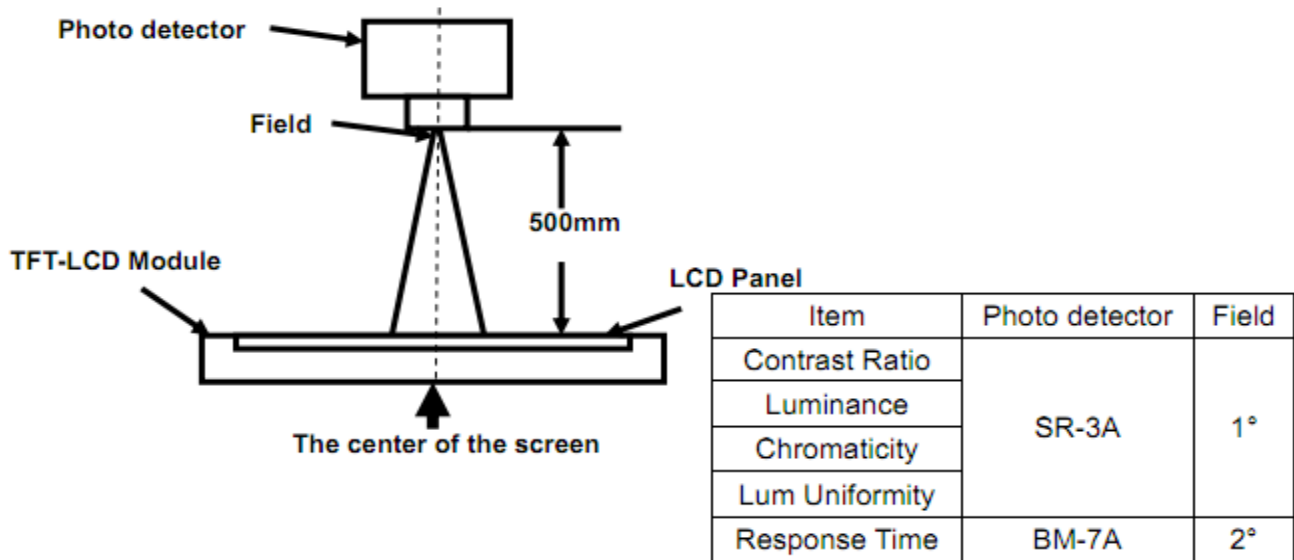

Note 2: Definition of viewing angle range and measurement system

Viewing angle is measured at the center point of the LCD by CONOSCOPE(ergo-80).

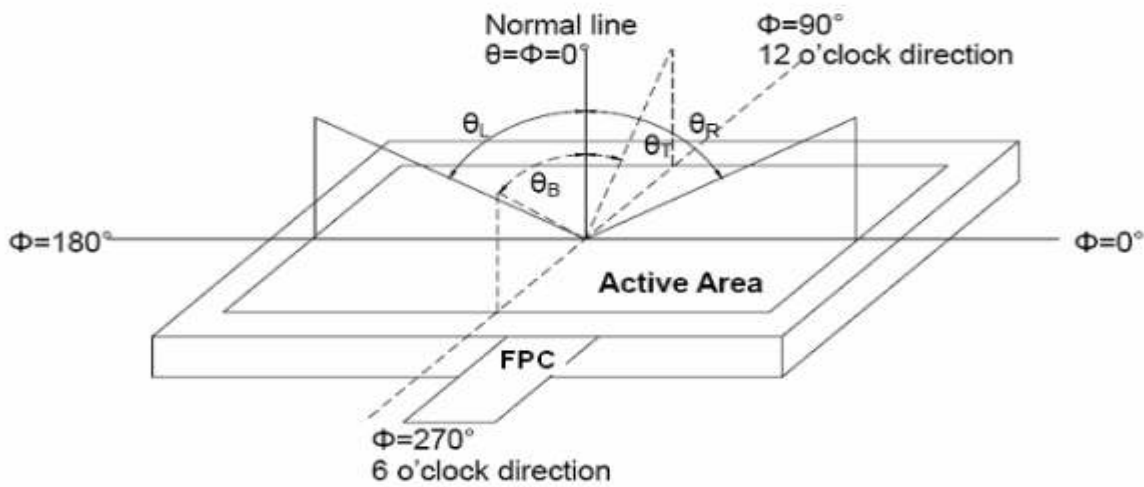

Fig. 1 Definition of viewing angle

Note 3: Definition of contrast ratio

$$CR = \frac{\text{Luminance with all pixels white}}{\text{Luminance with all pixels black}}$$

Note 4: Definition of Response time

The response time is defined as the LCD optical switching time interval between “White” state and “Black” state. Rise time (TON) is the time between photo detector output intensity changed from 90% to 10%. And fall time (TOFF) is the time between photo detector output intensity changed from 10% to 90%.

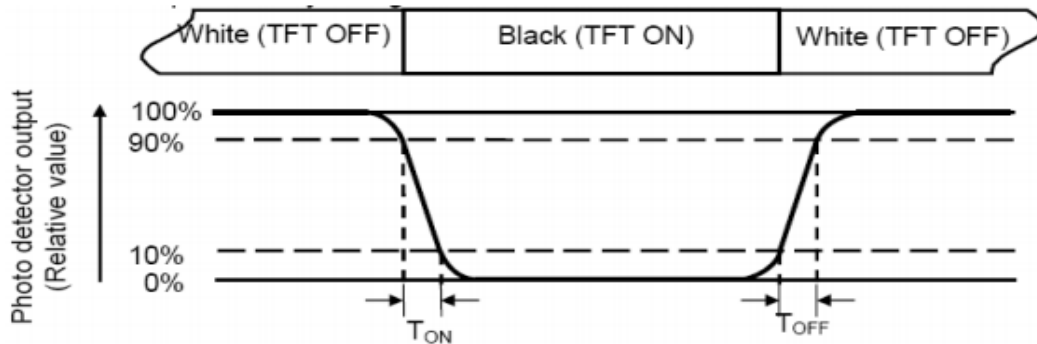

Note 5: Definition of color chromaticity (CIE1931)

Color coordinates measured at center point of LCD.

Note 6: Definition of Luminance Uniformity

The luminance uniformity in surface luminance is determined by measuring luminance at each test position 1 through n, and then dividing the maximum luminance of n points luminance by minimum luminance of n points luminance. For more information see FIG.2.

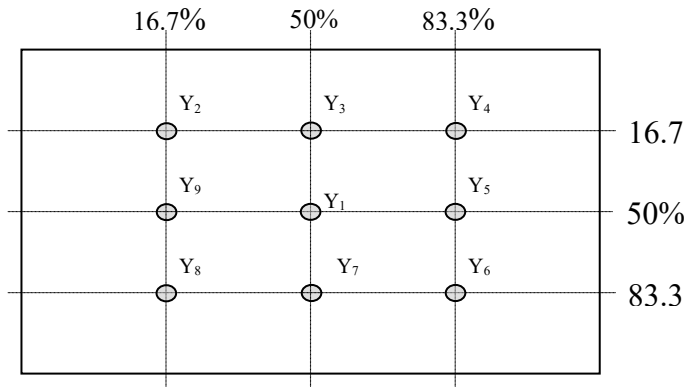

Fig. 2 Definition of points

Note 7: Definition of Luminance (Refer Fig. 2)

Surface luminance is the luminance with all pixels displaying white.

L_v = Average Surface Luminance with all white pixels (P1,P2,P3,,Pn).

8. Environmental/Reliability Test

Test Item	Test Conditions
High Temperature Storage	Ta= +80°C 96hrs
Low Temperature Storage	Ta= -30°C 96hrs
High Temperature Operation	Ta= +70°C 96hrs
Low Temperature Operation	Ta= -20°C 96hrs
High Temperature and Humidity Operation	Ta= +60°C, 90% RH 96hrs
Thermal Shock (Non-operation)	-30°C/30 min ~ +80°C/30 min for 20 cycles Start with cold temperature end with high temperature
Electro Static Discharge	Contact = ± 4 kV, class B Air = ± 8 kV, class B R=330Ω,C=150pF
Vibration	Sweep: 10Hz~55Hz~10Hz Stroke: 1.5mm 2 hours for each direction of X, Y, Z
Mechanical Shock	60G 6ms, ±X, ±Y, ±Z 3 times for each direction
Package Drop Test	Height: 60 cm 1 corner, 3 edges, 6 surfaces

Notes: The test result shall be evaluated after the sample has been left at room temperature and humidity for 2 hours without load. No condensation shall be accepted. The sample will not be accepted if appear these defects:

- 1). Air bubble in the LCD
- 2). Seal leak or Glass crack
- 3). Non display or abnormal display
- 4). Brightness reduction >50%

9. Mechanical Drawing

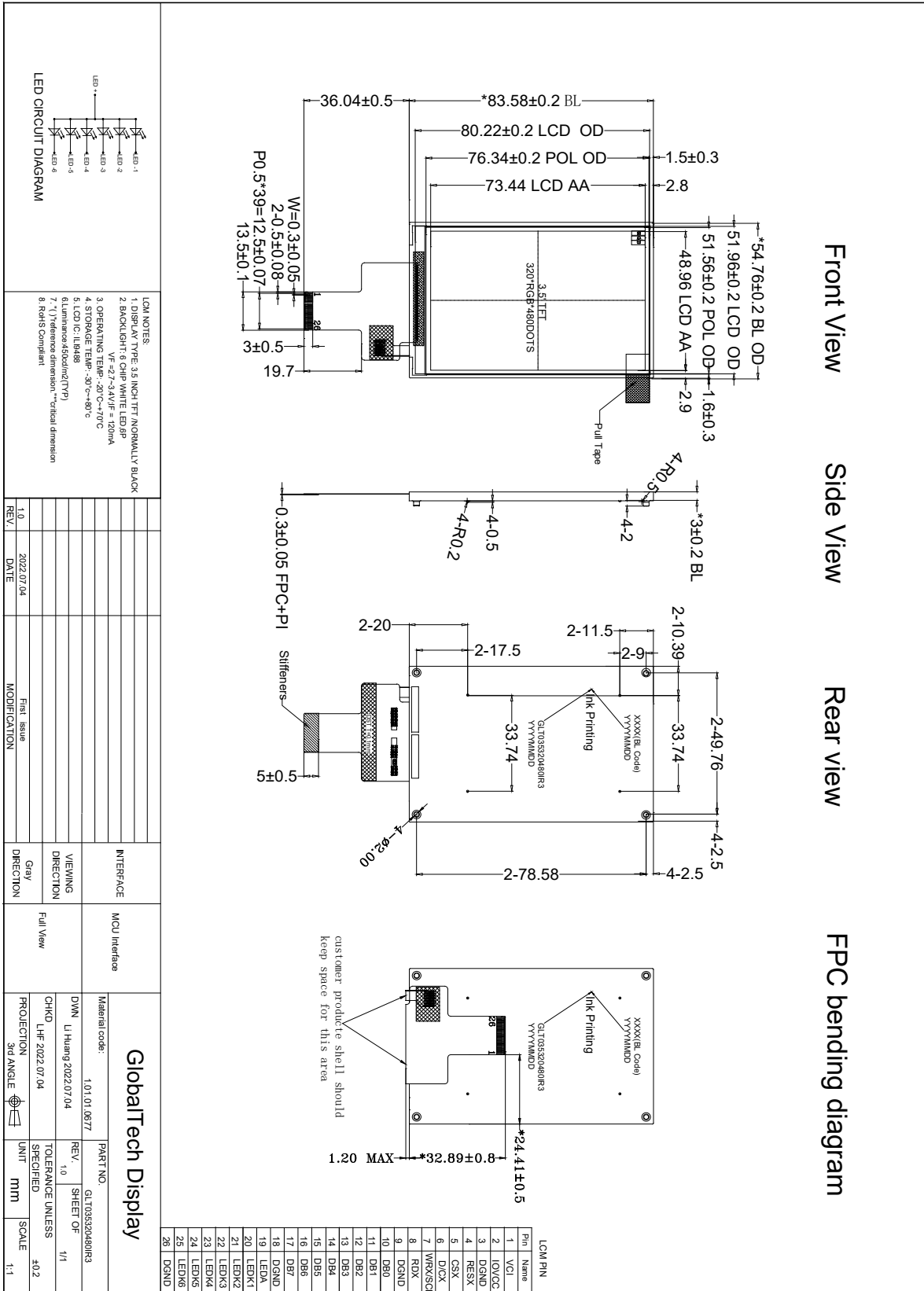

10. Packing

Packing Method

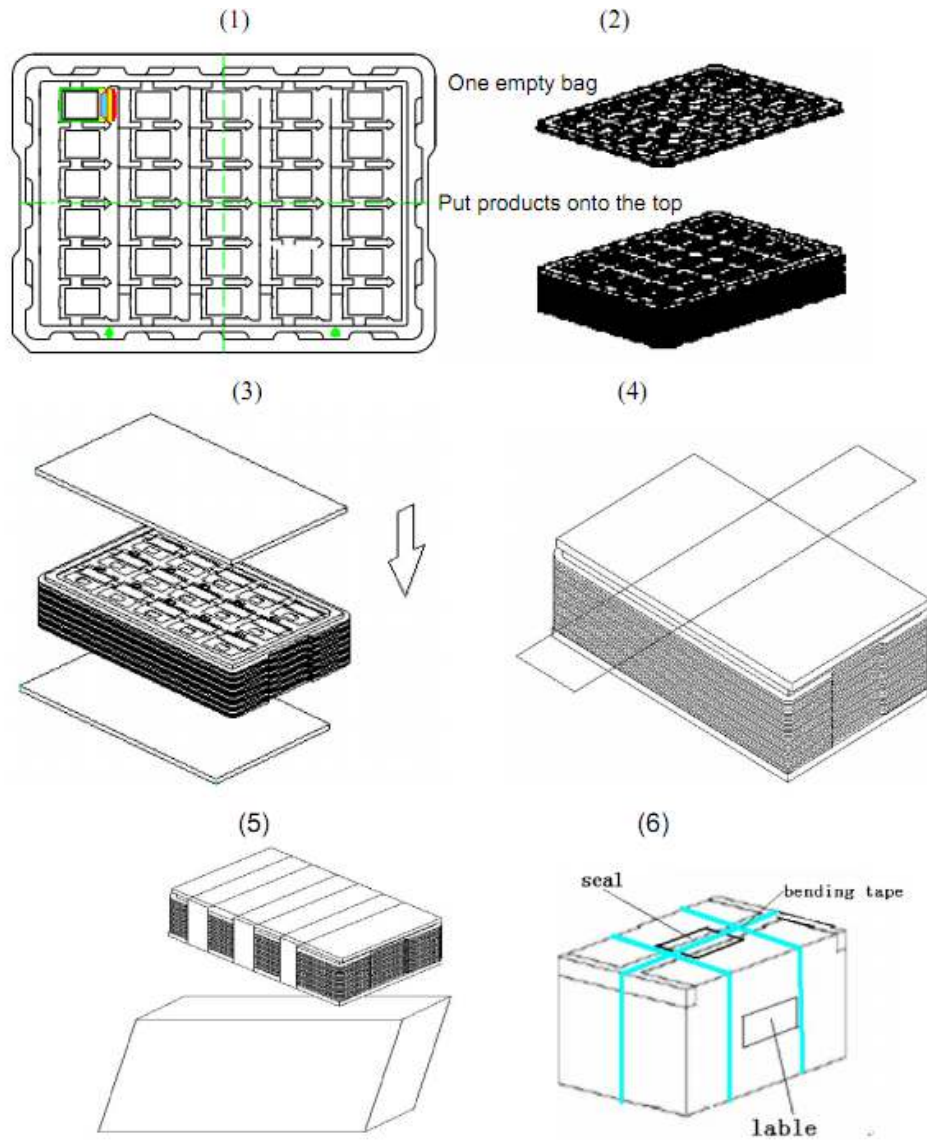

Steps:

1. Put module into tray cavity
2. Tray stacking
3. Put 1 cardboard under the tray stack and 1 cardboard above:
4. Fix the cardboard to the tray stack with adhesive tape:
5. Put the tray stack into carton.
6. Carton sealing with adhesive tape.

11. TFT-LCD Module Inspection Criteria

11.1 Scope

The incoming inspection standards shall be applied to TFT –LCD Modules (hereinafter called "Modules") that supplied by GlobalTech Display.

11.2 Incoming Inspection

The customer shall inspect the modules within twenty calendar days of the delivery date (the “inspection period”) at its own cost. The result of the inspection (acceptance or rejection) shall be recorded in writing, and a copy of this writing will be promptly sent to the seller, If the results of the inspecting from buyer does not send to the seller within twenty calendar days of the delivery date. The modules shall be regards as acceptance. Should the customer fail to notify the seller within the inspection period, the buyer’s right to reject the modules shall be lapsed and the modules shall be deemed to have been accepted by the buyer.

11.3 Inspection Sampling

11.3.1. Lot size: Quantity per shipment lot per model

11.3.2. Sampling type: Normal inspection, Single sampling

11.3.3. Inspection level: II

11.3.4. Sampling table: MIL-STD-105E

11.3.5. Acceptable quality level (AQL)

Major defect: AQL=0.65

Minor defect: AQL=1.00

11.4 Inspection Conditions

11.4.1 Ambient conditions:

a. Temperature: Room temperature $25\pm 5^{\circ}\text{C}$

b. Humidity: $(60\pm 10)\% \text{RH}$

c. Illumination: Single fluorescent lamp non-directive (300 to 700 Lux)

11.4.2 Viewing distance

The distance between the LCD and the inspector’s eyes shall be at least $35\pm 5\text{ cm}$.

11.4.3 Viewing Angle

U/D: $45^{\circ}/45^{\circ}$, L/R: $45^{\circ}/45^{\circ}$

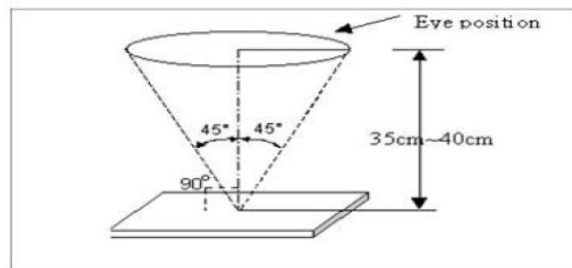

11.5 Inspection Criteria



Defects are classified as major defects and minor defects according to the degree of defectiveness defined herein.

11.5.1. Major defect

Item No	Items to be inspected	Inspection Standard
5.1.1	All functional defects	1) No display 2) Display abnormally 3) Short circuit 4) line defect
5.1.2	Missing	Missing function component
5.1.3	Crack	Glass Crack

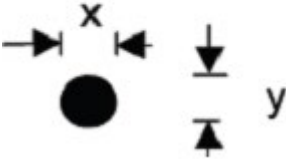
11.5.2. Minor defect

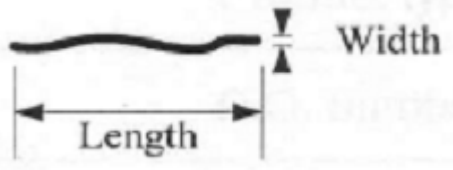
Item No	Items to be inspected	Inspection standard	
5.2.1	Spot Defect Including Black spot White spot Pinhole Foreign particle Polarizer dirt	For dark/white spot is defined $\varphi = (x+y) / 2$ 	
		Size φ (mm)	Acceptable Quantity
		$\varphi \leq 0.1$	Ignore
		$0.1 < \varphi \leq 0.2$	2
		$0.2 < \varphi$	Not allowed
5.2.2	Polarizer dirt, particle	Size φ (mm)	Acceptable Quantity
		$\varphi \leq 0.2$	1
		$\varphi > 0.2$	Not allowed

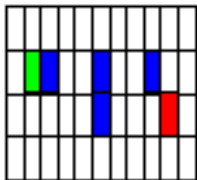
5.2.3	Line Defect Including Black line White line Scratch	Define: 	
		Width(mm) Length(mm)	Acceptable Quantity
		$W \leq 0.05$	Ignore
		$0.05 < W \leq 0.1$ $L \leq 1.5$	1
		$0.1 < W, \text{ or } L > 1.5$	Not allowed
5.2.4	Polarizer Dent/Bubble	Not allowed	
5.2.5	Electrical Dot Defect	Bright and Black dot define: 	
		 Two Adjacent Dot	
		Inspection pattern: Full white、 Full black、 Red、 green and blue screens	
		Item	Acceptable Quantity
		Black dot defect	1
Bright dot defect	1	(5mm ≤ Distance)	
Two Adjacent Dot	Not allow		
	There or more Adjacent Dot	Not allowed	
	Total Dot	2	

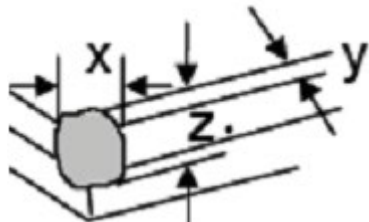
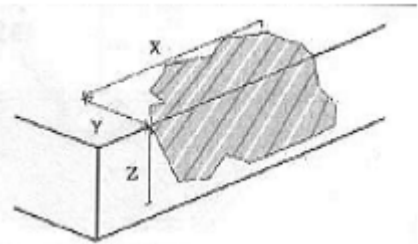
5.2.6	Glass defect	 <p>1. Corner Fragment:</p>	
		Size(mm)	Acceptable Quantity <input type="checkbox"/>
		X≤2mm Y≤1mm Z≤T	Ignore T:Glass thickness X: Length Y: Width Z: thickness
		 <p>2. Side Fragment: <input type="checkbox"/></p>	
		Size(mm)	Acceptable Quantity
		X≤5mm Y≤1mm Z≤T	Ignore T:Glass thickness X: Length Y: Width Z: thickness

- Note:
- 1). Dot defect is defined as the defective area of the dot area is larger than 50% of the dot area.
 - 2). The distance between two bright dot defects (red, green, blue, and white) should be larger than 15mm.
 - 3). The distance between black dot defects or black and bright dot defects should be more than 5mm apart.
 - 4). Polarizer bubble is defined as the bubble appears on active display area. The defect of polarizer bubble shall be ignored if the polarizer bubble appears on the outside of active display area.

11.6 Mechanics specification

As for the outside dimension, weight of the modules, please refer to product specification for more details.

12. Precautions for Use of LCD modules

12.1 Handling Precautions

12.1.1. The display panel is made of glass. Do not subject it to a mechanical shock by dropping it from a high place, etc.

12.1.2. If the display panel is damaged and the liquid crystal substance inside it leaks out, be sure not to get any in your mouth, if the substance comes into contact with your skin or clothes, promptly wash it off using soap and water.

12.1.3. Do not apply excessive force to the display surface or the adjoining areas since this may cause the color tone to vary.

12.1.4. The polarizer covering the display surface of the LCD module is soft and easily scratched. Handle this polarizer carefully.

12.1.5. If the display surface is contaminated, breathe on the surface and gently wipe it with a soft dry cloth. If still not completely clear, moisten cloth with one of the following solvents:

- Isopropyl alcohol
- Ethyl alcohol

Solvents other than those mentioned above may damage the polarizer. Especially, do not use the following:

- Water
- Ketene
- Aromatic solvents

12.1.6. Do not attempt to disassemble the LCD Module.

12.1.7. If the logic circuit power is off, do not apply the input signals.

12.1.8. To prevent destruction of the elements by static electricity, be careful to maintain an optimum work environment.

12.1.8.1. Be sure to ground the body when handling the LCD Modules.

12.1.8.2. Tools required for assembly, such as soldering irons, must be properly ground.

12.1.8.3. To reduce the amount of static electricity generated, do not conduct assembly and other work under dry conditions.

12.1.8.4. The LCD Module is coated with a film to protect the display surface. Be care when peeling off this protective film since static electricity may be generated.

12.2 Storage Precautions

12.2.1. When storing the LCD modules, avoid exposure to direct sunlight or to the light of fluorescent lamps.

12.2.2. The LCD modules should be stored under the storage temperature range if the LCD modules will be stored for a long time, the recommend condition is: Temperature : 0°C ~40°C Relatively humidity: ≤80%

12.2.3. The LCD modules should be stored in the room without acid, alkali and harmful gas.

12.3 Transportation Precautions

The LCD modules should be no falling and violent shocking during transportation, and also should avoid excessive press, water, damp and sunshine.