

FRONT VIEW

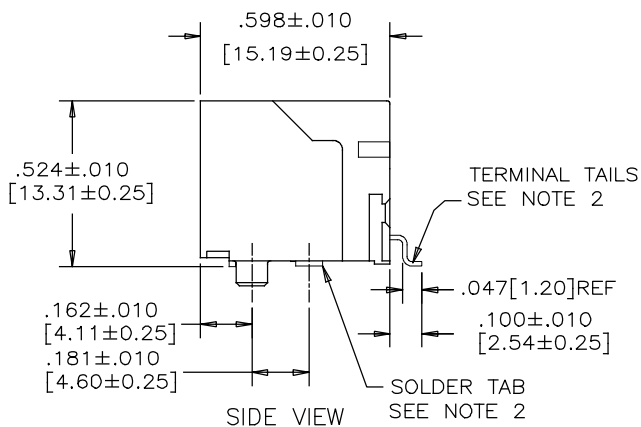

SIDE VIEW

REVISIONS				
SYM	ZONE	ECN, ERN NO.	DATE	APPRD.
A		PROPOSAL	2005/03/07	L.C
B		PROPOSAL	SEP 24, 2010	L.C
C		CORRECT DIMENSION	JAN 18, 2016	L.C

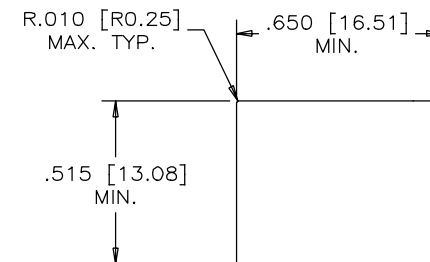

RECOMMENDED PANEL CUTOUT

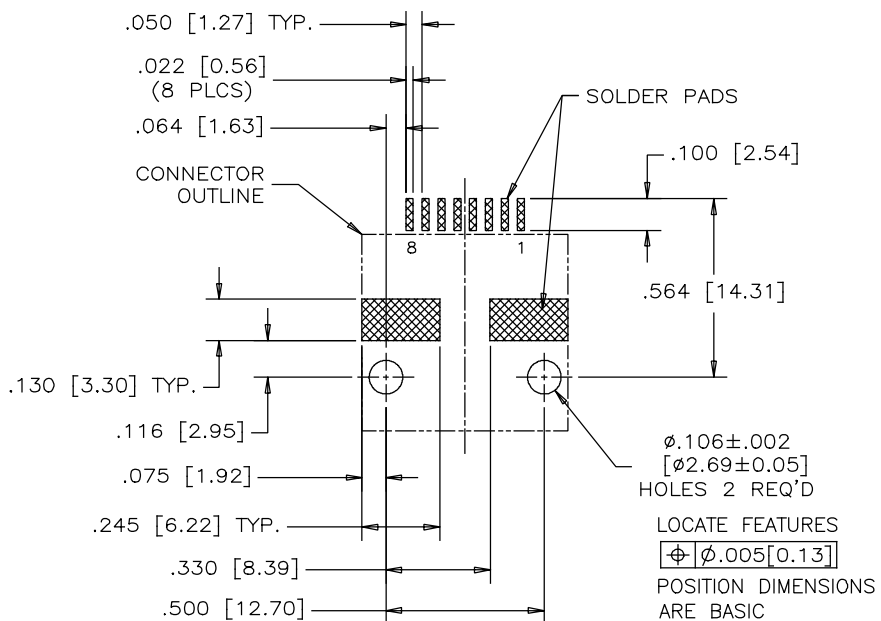

RECOMMENDED P.C.B. LAYOUT
(COMPONENT SIDE OF BOARD)
(TOLERANCE: ±0.05mm)

NOTES:

1. MATERIALS:

PLASTIC HOUSING: HIGH TEMPERATURE THERMOPLASTIC
FLAMMABILITY RATING UL 94V-0

CONTACTS:

PHOSPHOR BRONZE
PLATING: 20 u" [0.508 MICRONS]
MIN. GOLD ON MATING SURFACES.
50 u" [1.27 MICRONS]
MIN. NICKEL UNDERPLATE.
100 u" [2.54 MICRONS]
MIN. MATTE TIN OR GOLD FLASH
ON CONTACT TAILS.

SOLDER TAB:

COPPER ALLOY WITH TIN PLATING

2. COPLANARITY SPECIFICATION:

WITH THE MODULAR JACK SITTING ON A
LEVEL SURFACE, THE MAXIMUM GAP BETWEEN
THE LEVEL SURFACE AND ALL TERMINAL TAILS
AND BOTH FITTING NAILS IS 0.004 [0.01mm].

SUITABLE FOR SOLDERING IN ACCORDANCE JEDEC-020C STANDARD.

PART NUMBER: RJ SSE-5080-01T

MATERIAL	DRAWN	L.DENG	DATE	Amphenol Canada Corp.			
	DESIGNED	L.DENG	2005/03/04				
FINISH	CHECKED	J.SI	2005/03/07	TITLE			
	I. E. APPRD.					SURFACE MOUNT MODULAR JACK 8 POSITION, 8 CONTACTS, TAPE & REEL PACKAGING, RoHS COMPLIANT	
	Q. A. APPRD.			DWG	DRAWING NO.		
	ENG. REL. NO.			C	P-RJSSE-5080-01T	C	
	REF.	EAR# 12663		SCALE	WT.	SURF.	SHEET 1 of 2
	DIMENSIONS ARE IN INCHES [mm]		03554				

THIS DOCUMENT CONTAINS PROPRIETARY INFORMATION AND SUCH INFORMATION
MAY NOT BE DISCLOSED TO OTHERS FOR ANY PURPOSE OR USED FOR MANUFACTURING
PURPOSES WITHOUT WRITTEN PERMISSION FROM AMPHENOL CANADA CORP.

REVISIONS				
SYM	ZONE	ECN, ERN NO.	DATE	APPRD.
A		PROPOSAL	2005/03/07	L.C
B		PROPOSAL	SEP 25,2010	L.C
C		CORRECT DIMENSION	JAN 18,2016	L.C

THIS IS A CAD DRAWING. DO NOT MANUALLY REVISE.

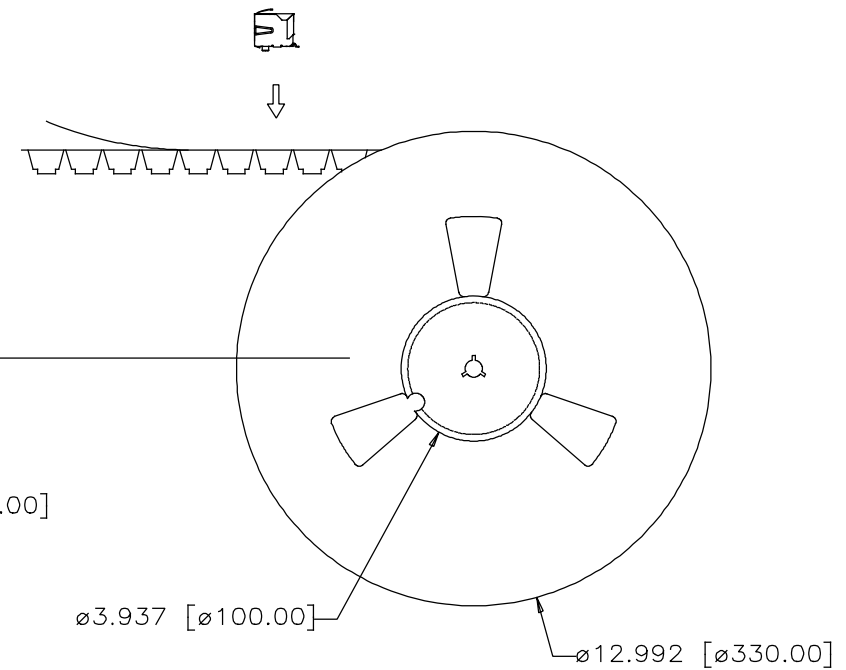
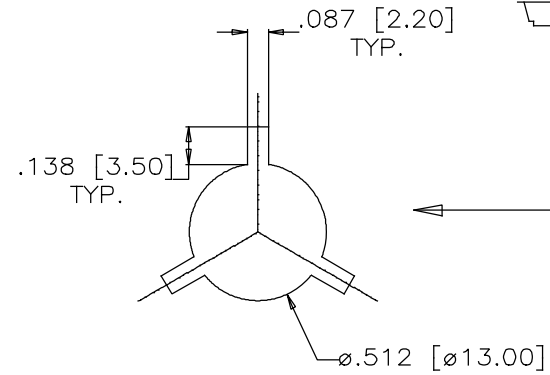
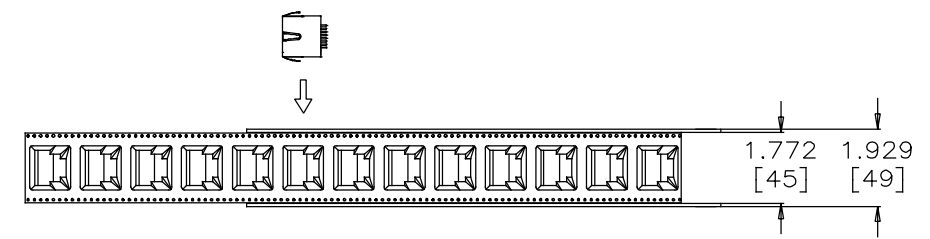
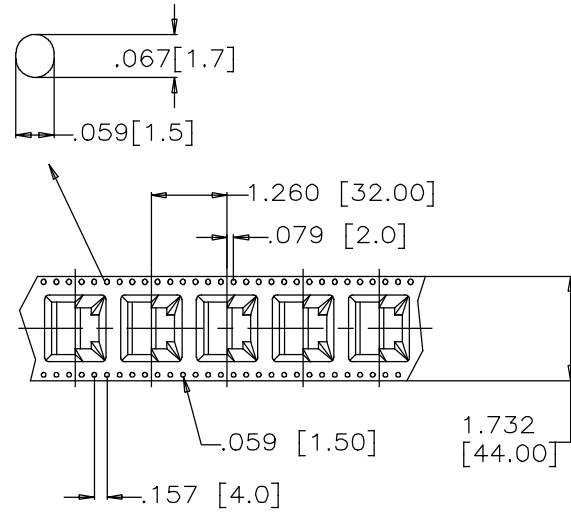
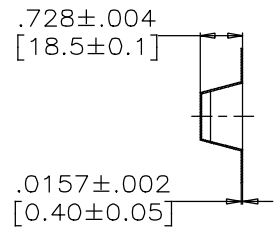

PACKAGING NOTES:

1. ONE REEL SHOULD HOLD 100 CONNECTORS.
2. 10 EMPTY CAVITIES FOR BOTH TOP AND BOTTOM OF THE CARRIER.
3. A FULLY LOADED CARTON SHOULD CONTAIN 6 REELS (600 PCS) OF CONNECTOR.

MATERIAL -----	DRAWN L.DENG	DATE 05/03/04	Amphenol Canada Corp.
	DESIGNED L.DENG	05/03/04	
FINISH -----	CHECKED J.SI	05/03/07	
	I. E. APPRD. X	X	
	Q. A. APPRD. X	X	
	DWG. APPRD. X	X	
ENG. REL. NO. X	TITLE SURFACE MOUNT MODULAR JACK 8 POSITION, 8 CONTACTS, TAPE & REEL PACKAGING, RoHS COMPLIANT		
REF. EAR 12663	DWG. C	DRAWING NO. P-RJSSE-5080-01T	REV. C
DIMENSIONS ARE IN INCHES [mm]	CODE ID. NO. 03554	SCALE	WT. -----
		SURF. -----	SHEET 2 OF 2

THIS DOCUMENT CONTAINS PROPRIETARY INFORMATION AND SUCH INFORMATION MAY NOT BE DISCLOSED TO OTHERS FOR ANY PURPOSE OR USED FOR MANUFACTURING PURPOSES WITHOUT WRITTEN PERMISSION FROM AMPHENOL CANADA CORP.