

CoreLED P/N 12003

- 74° side emitting optic
- Compatible with following LED products
 - 2020 LED package or smaller
 - Other LED packages may be compatible (Contact CoreLed Engineering for requests)

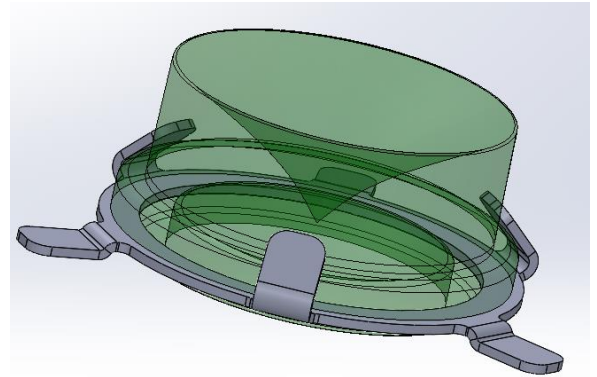

SMO Product Description:

The SMO product family is a series of injection molded high-temperature silicone miniature lenses that attach directly to PCB with solder clip using standard reflow method. These components achieve high light collection efficiency, a variety of engineered beam patterns, and are supplied for high volume pick and place electronics assembly.

Key Features:

- Optical lens is reflow mounted at the same time as LED assembly
- Supplied in tape and reel
- Increased control of light output
- Precision alignment (within ± 0.1 mm)
- Family of optical beam patterns that will work using IR reflow
- Reflow solder clip directly attached to lens
- Standard pick and place equipment
- Manufactured without the need for additional components to attach the optics

Emitted Pattern Profile

Nichia E17 (Measured) 1717 LED package

IES Classification	Type V
Longitudinal Classification	Short
Cutoff Classification (deprecated)	Non-Cutoff
Total Rated Lamp Lumens	524
Max. Candela	188.93
Max. Candela Angle	40.0H 74.0V
Total Lamp Lumens	100
Downward Total Efficiency	82.2%

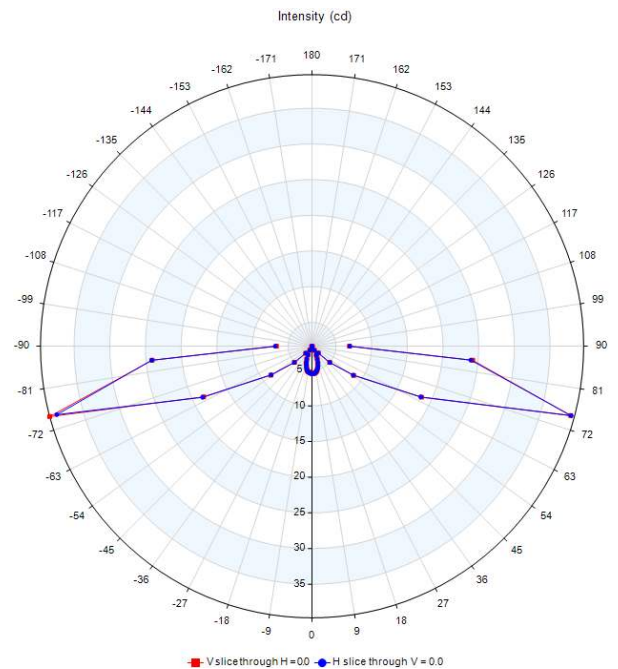
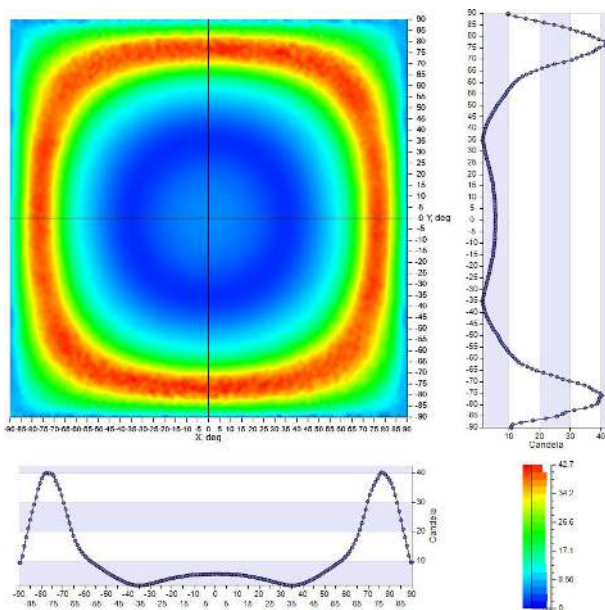

ANGULAR DISTRIBUTION OF LUMINOUS INTENSITY (cd)

POLAR INTENSITY PLOT
BATWING 74° PEAK

IES files and Raytrace models are available upon request from
CoreLed Engineering.

Mechanical Profile

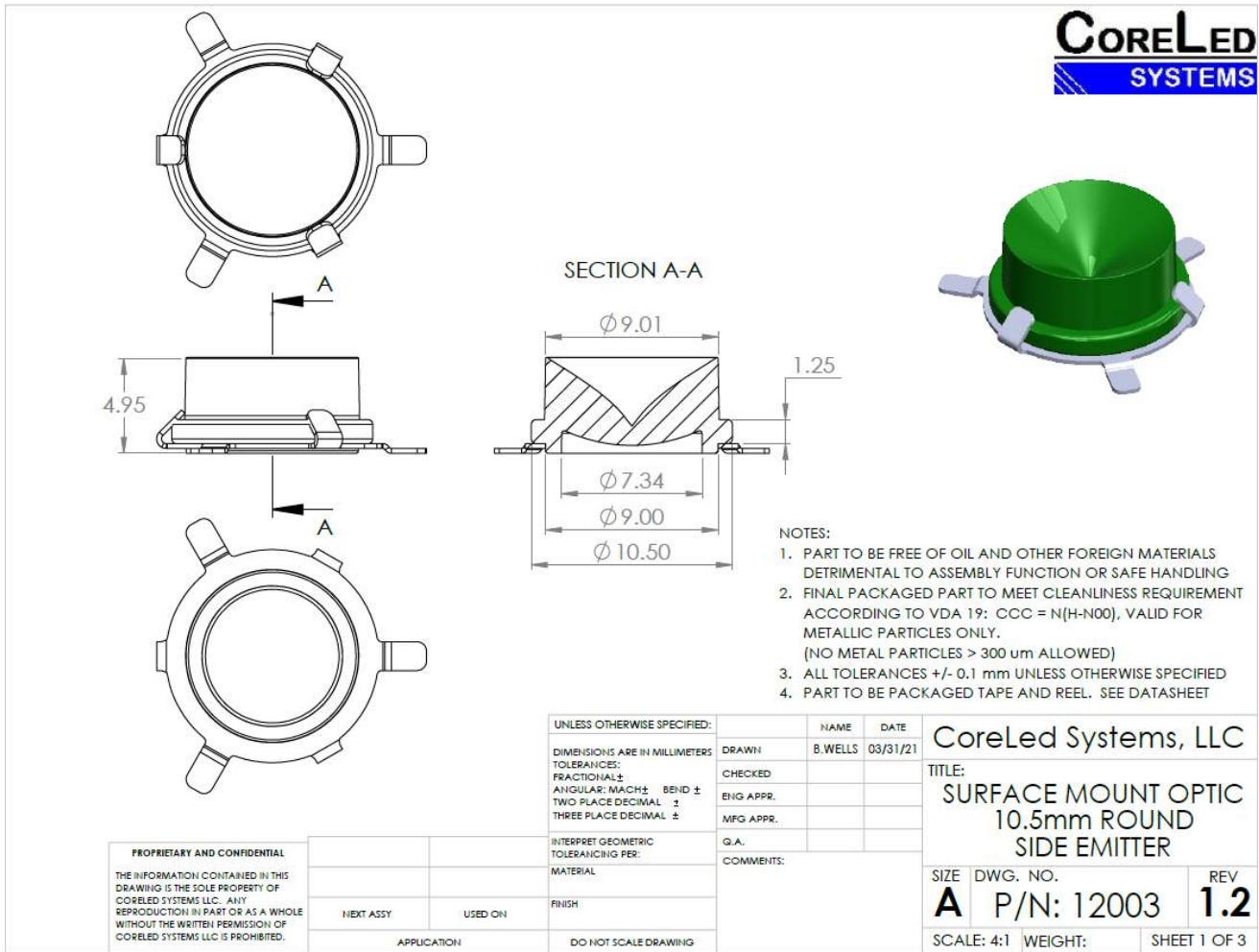

Mechanical design features shown with solder clip

CAD files available upon request from CoreLed Engineering

Reflow Profile

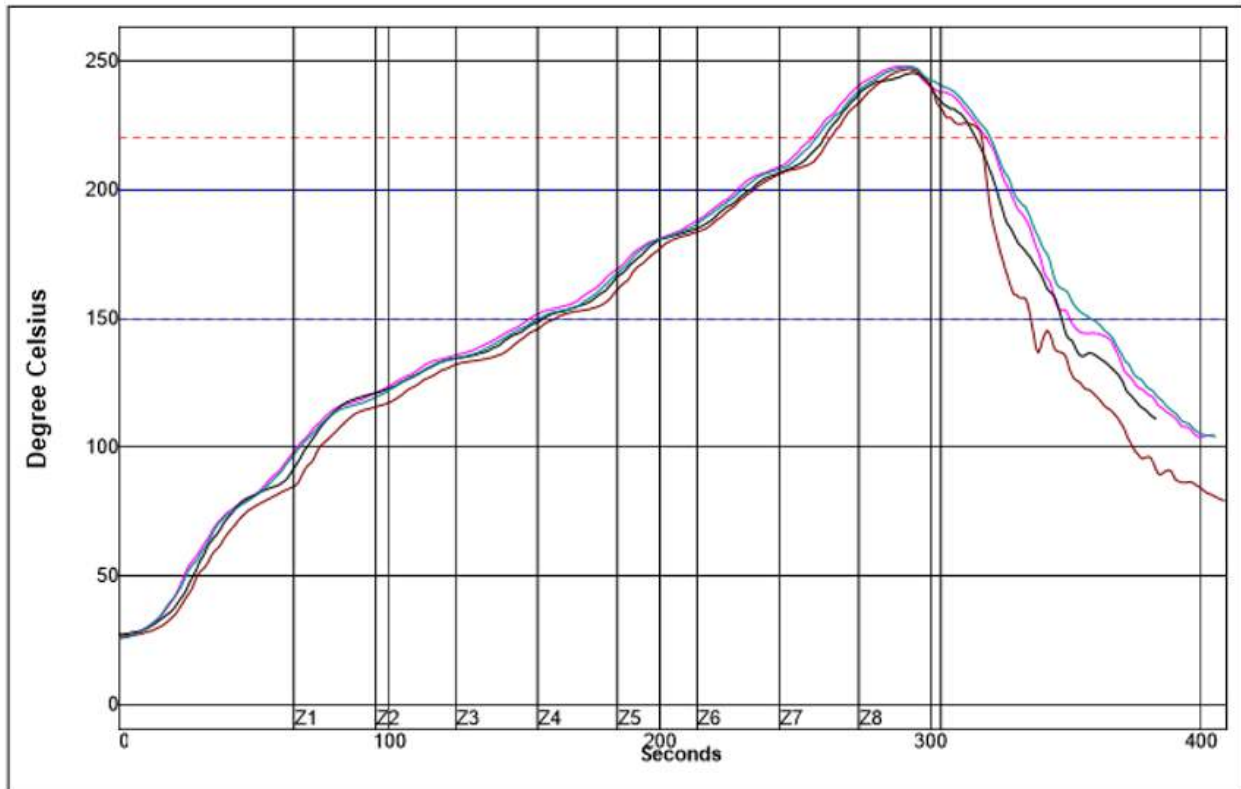

Setpoints (Degree Celsius)								
Zone	1	2	3	4	5	6	7	8
Top	125	148	152	173	210	235	268	257
Bottom	125	148	152	173	210	235	268	257
Conveyor Speed	50.0 cm/min							

Example Reflow profile used for testing of SMO units by CoreLed

Solder Pad drawing

Dimensions are in mm

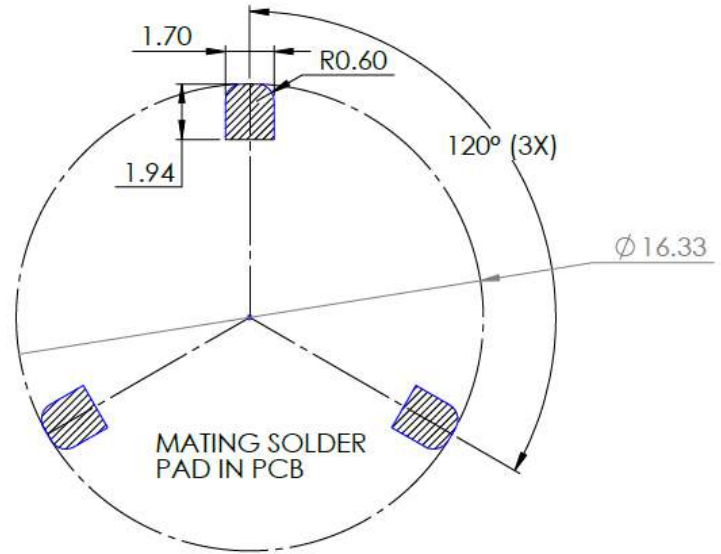

Solder area denoted in green

Packaging Example (pocket depth will change to match lens height)

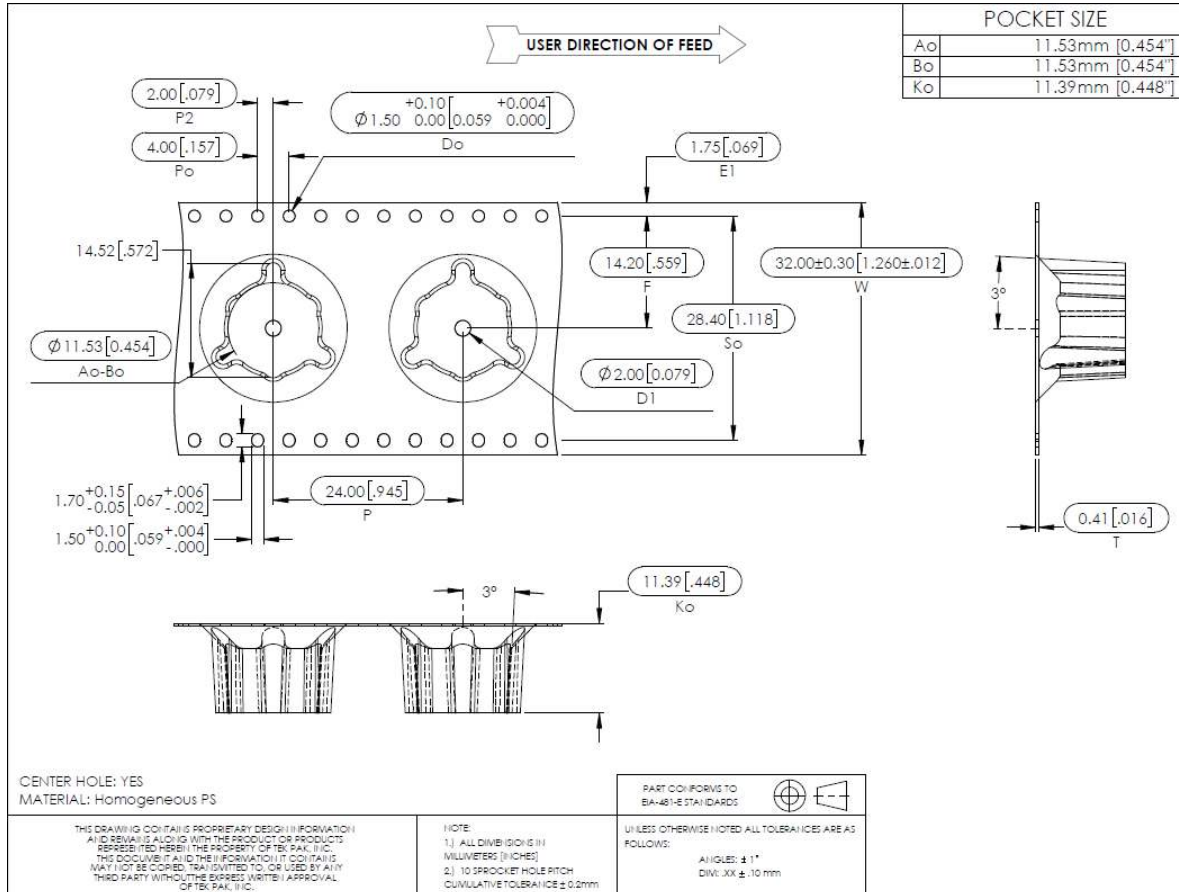

Contact CoreLED for product-specific pocket depth

Packaging information for tape and reel delivery.

