

PROPRIETARY INFORMATION  
 NOT TO BE RELEASED  
 WITHOUT WRITTEN PERMISSION  
 FROM AN AUTHORIZED  
 REPRESENTATIVE OF  
 APPLIED ENGINEERING PRODUCTS

REVISIONS			
REV.	DESCRIPTION	DATE	APPROVED
A	INITIAL RELEASE	05/22/08	A.D.M.

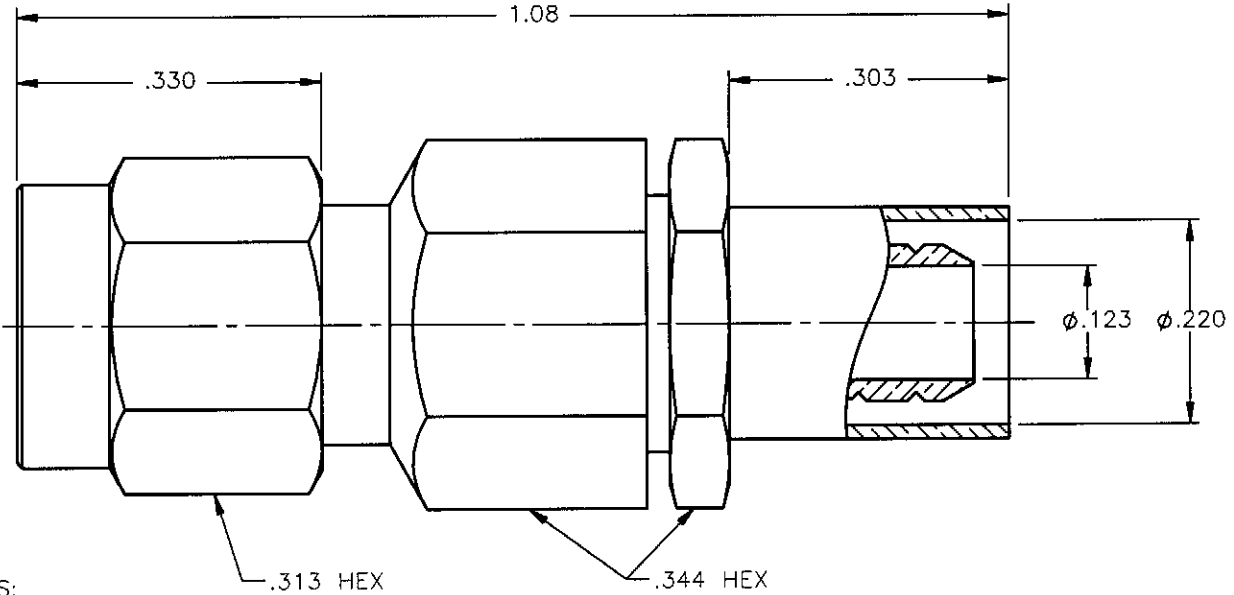

NOTES:

MATERIALS:

1. BODY & COUPLING NUT = STAINLESS STEEL PER ASTM A582, ALLOY 303, CONDITION "A".
2. INSULATORS = VIRGIN WHITE TEFLON PER ASTM D1710, GRADE 1, TYPE I, CLASS "B".
3. CONTACT & RETAINING RING = BERYLLIUM COPPER PER ASTM B196, ALLOY C17300, TEMPER TD04.
4. GASKET = SILICONE RUBBER PER ZZ-R-765, CLASS 2B, GRADE 65-75.
5. CRIMP NUT = BRASS PER ASTM B16, ALLOY C36000, TEMPER H02.
6. CRIMP SLEEVE = SEAMLESS LOWLEAD BRASS TUBE, ALLOY 330, SOFT ANNEAL TEMPER, .025/.060 GRAIN SIZE OR SEAMLESS COPPER TUBE PER ASTM B75, TYPE C12000, TEMPER: LIGHT ANNEAL O50 EXCEPT YIELD STRENGTH, OR BRASS PER MIL-T-46072, ALLOY 332.
7. SHRINK SLEEVE = THERMOFIT SCL, BLACK. (NOT SHOWN)

FINISHES:

1. BODY & COUPLING NUT = PASSIVATE PER QQ-P-35, TYPE VI.
2. CONTACT = GOLD PLATE PER MIL-G-45204, TYPE II, CLASS 1, GRADE C, OVER .00010 TO .00020 STRESS FREE SULFAMATE NICKEL PER QQ-N-290.
3. CRIMP NUT & CRIMP SLEEVE = NICKEL PLATE PER QQ-N-290, CLASS 1, GRADE G, EXCEPT .0001 TO .0002 THICK OVER .00005 TO .0001 THICK COPPER PER MIL-C-14550.

UNLESS OTHERWISE SPECIFIED DIMENSIONS ARE IN INCHES TOLERANCES ON	DWN: A.D.M.	DATE 05/22/08	 <b>APPLIED ENGINEERING PRODUCTS</b> 104 John W. Murphy Dr. New Haven, CT 06513 a <b>RADIALL</b> company		
	CHKD:	DATE 05/22/08			
DECIMAL	ANGLE	D.N. J.M.	<b>SMA STRAIGHT PLUG          CRIMP TYPE          FOR RG-55 &amp; SIMILAR CABLES</b>		
		APVD: J.M.			
REFERENCE:	MATERIALS & FINISHES: SEE NOTES	SIZE A	FSCM NO. 19505	DWG NO. 9101-9573-001	REV A
ORIGINATED: A.D.M. DATE: 05/22/08		SCALE 5:1	THIRD ANGLE PROJECTION	SHEET 1 OF 1	

9101-9573-001