

PI2EQX638

1.8V 5.0Gbps, 2-port, USB 3.0 Mux/DeMux ReDriver™

Features

- USB 3.0 compatible
- Full Compliancy to USB3.0 Super Speed Standard
- 1 to 2 DeMux from host TX to device RX
- 2 to 1 Mux from device TX to Host RX
- Pin Adjustable Receiver Equalization
- Pin Adjustable output swing
- Pin Adjustable Output Emphasis
- 100Ω Differential CML I/O's
- Input signal level detect and squelch for each channel
- Automatic Receiver Detect
- Low Power : 200mw
- Adaptive power management
 - ◆ 0.54mW/0.3mA (typ) in U2/U3 state
 - ◆ 0.54mW/0.3mA (typ) in no connection state
 - ◆ 26mW/14mA (typ) in U1 state
 - ◆ 0.18mW/0.1mA(typ) in Power down state
- Single Supply Voltage: 1.8V
- Totally Lead-Free & Fully RoHS Compliant (Notes 1 & 2)
- Halogen and Antimony Free. "Green" Device (Note 3)
- Packaging:
 - ◆ 18-Pin XUB18 2x2 mm

Description

Diodes' PI2EQX638 is a low power, high performance 5.0 Gbps 2-Port USB3.0 Mux / DeMux ReDriver™ designed specifically for the USB 3.0 protocol.

The device provides programmable equalization, swing and De-Emphasis to optimize performance over a variety of physical mediums by reducing Inter-Symbol Interference. PI2EQX638 supports two 100Ω Differential CML data I/O's between the Protocol ASIC to a switch fabric, over cable, or to extend the signals across other distant data pathways on the user's platform.

The integrated equalization circuitry provides flexibility with signal integrity of the signal before the ReDriver. A low-level input signal detection and output squelch function is provided for each channel. Each channel operates fully independently. The channels' input signal level (on xI+/-) determines whether the output is active.

The PI2EQX638 also includes an adaptive power management feature to maximize battery life for power sensitive consumer devices.

Block Diagram

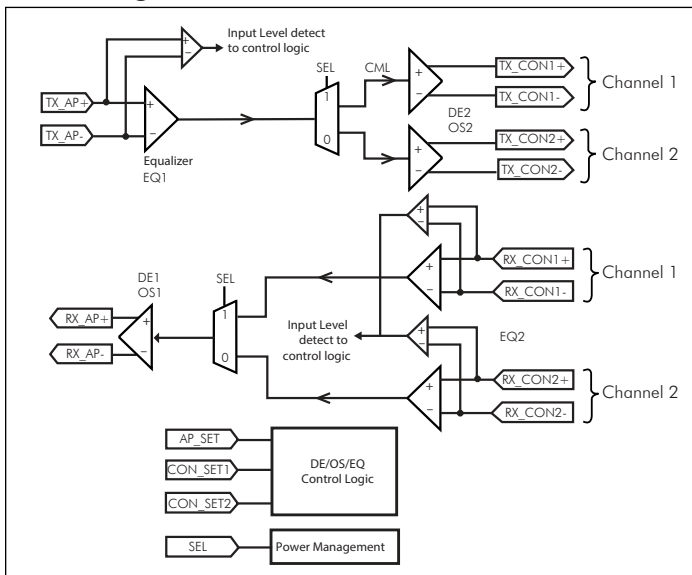
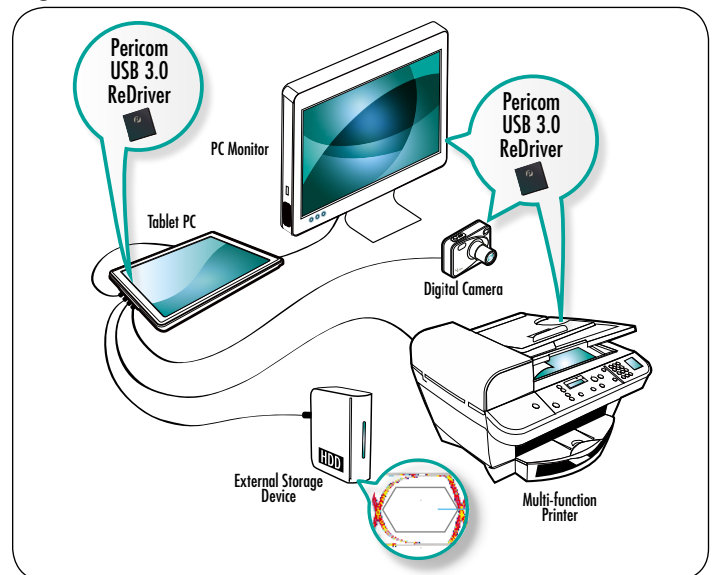

Figure 1



Notes:

1. No purposely added lead. Fully EU Directive 2002/95/EC (RoHS), 2011/65/EU (RoHS 2) & 2015/863/EU (RoHS 3) compliant.
2. See <https://www.diodes.com/quality/lead-free/> for more information about Diodes Incorporated's definitions of Halogen- and Antimony-free, "Green" and Lead-free.
3. Halogen- and Antimony-free "Green" products are defined as those which contain <900ppm bromine, <900ppm chlorine (<1500ppm total Br + Cl) and <1000ppm antimony compounds.

Pin Diagram (Top Side View)

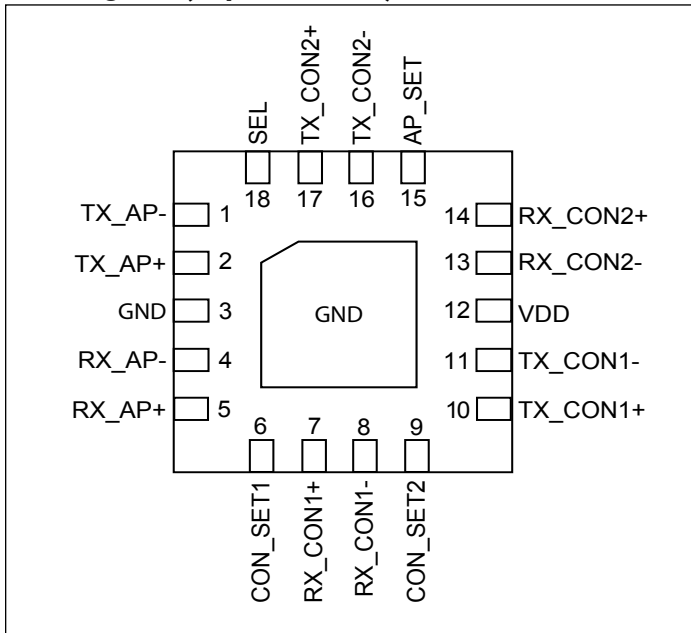

Pin Description

Pin #	Pin Name	Type	Description
12	VDD	Power	1.8V power supply, +/- 0.1V.
6, 9	CON_SET1, CON_SET2	Input	Connector Side Setting: DE2/OS2/EQ2 setup. 2 x 3-level input pins. With internal 150K Ω pull-up resistor and 150k Ω pull-down resistor.
2, 1 7, 8 14, 13	TX_AP+, TX_AP- RX_CON1+, RX_CON1- RX_CON2+, RX_CON2-	Input	CML input terminals. With selectable input termination between 50 Ω to internal VbiasRx or 67k Ω to GND.
5, 4 10, 11 17, 16	RX_AP+, RX_AP- TX_CON1+, TX_CON1- TX_CON2+, TX_CON2-	Output	CML output terminals. With selectable output termination between 50 Ω to internal voltage bias, 2K to GND or Hi-Z.
3, Center Pad	GND	GND	Supply Ground.
15	AP_SET	Input	Application Processor Side Setting: DE1/EQ1 setup 3-level input pins. With internal 150K Ω pull-up resistor and 150k Ω pull-down resistor.
18	SEL	Input	Mode Selection Pin. 3-level input pin. With internal 150K Ω pull-up resistor and 150k Ω pull-down resistor. "High" – Channel 1 Active "Low" – Channel 2 Active "Float" – Both Channels are power down (Default)

Power Management

PI2EQX638 USB3.0 Active Switch includes an adaptive power management feature to support long battery run-time ideal for power-sensitive Smart Mobile Devices. PI2EQX638 is equipped with two differential paths, one is from application processor side to type-C connector side and the other is from type-C connector side to application processor side. Each path has 4 power modes: active mode, slumber mode, deep slumber mode and unplug mode. These power modes are managed by the adaptive power management feature according to the link status. The feature does not decode the USB3.x power management commands to obtain the link status, it relies on link electrical condition, internal timer and internal state machine. Hence, the feature can optimize the power saving in U1 (slumber mode), U2/U3 (deep slumber mode) and no connection state (Either no device is connected to the type-C connector or the receiver terminal of the connected device is in high impedance mode).

De-emphasis / Output Swing / Equalization Configuration Table for Application Processor Side:

Application Processor Side DE/OS/EQ Settings			
AP_SET	DE1	OS1	EQ1
0	0dB	1.1V	3dB
Float	-3.5dB	1.1V	3dB(Default)
1	-3.5dB	1.1V	6dB

De-emphasis / Output Swing / Equalization Configuration Table for Connector Side:

Connector Side DE/OS/EQ Settings				
CON_SET1	CON_SET2	DE2	OS2	EQ2
0	0	0dB	1.1V	3dB
	Float	-3.5dB	1.1V	3dB
	1	0dB	1.0V	3dB
Float	0	-3.5dB	1.0V	3dB
	Float	0dB	1.1V	6dB (Default)
	1	-3.5dB	1.1V	6dB
1	0	0dB	1.0V	6dB
	Float	-3.5dB	1.0V	6dB
	1	-3.5dB	1.1V	9dB

Unused Channel and Power down Configuration Table (single ended)

	Input R	Output R
Unused channel and Power down	67kΩ to GND	HiZ

Maximum Ratings

(Above which useful life may be impaired. For user guidelines, not tested.)

Storage Temperature.....	-65°C to +150°C
Supply Voltage to Ground Potential.....	-0.5V to +2V
DC SIG Voltage.....	-0.5V to V _{DD} +0.5V
Output Current.....	-25mA to +25mA
Power Dissipation Continuous.....	0.5W
Operating Temperature.....	-40°C to +85°C
ESD, Human Body Model.....	-2kv to +2kV

Note:

Stresses greater than those listed under MAXIMUM RATINGS may cause permanent damage to the device. This is a stress rating only and functional operation of the device at these or any other conditions above those indicated in the operational sections of this specification is not implied. Exposure to absolute maximum rating conditions for extended periods may affect reliability.

RECOMMENDED OPERATING CONDITIONS

Symbol	Parameter	Conditions	Min.	Typ.	Max.	Units
DEVICE PARAMETERS						
maximum data rate					5	Gbps
t _{idle_out}	Slumber mode exit time	LFPS signal		20		ns
t _{idle_in}	Slumber mode entry time	Electrical idle		1.3		ms
t _{dsm_in}	Deep Slumber mode entry time	Electrical idle		330		ms
Tri-Level Leakage						
I _{IH}	Input High Current				50	uA
I _{IL}	Input LOW Current		-50			
Tri-level Control Pins						
V _{IH}	Input High Voltage		0.85V _{dd}			V
V _{IL}	Input Low Voltage				0.15V _{dd}	
V _{IMID}	Input Mid Voltage		0.35V _{dd}	0.5V _{dd}	0.65V _{dd}	
C _L	Loading Capacitance				150	pF

AC/DC Electrical Characteristics

1.8V Power Supply Characteristics						
Symbol	Parameter	Conditions	Min.	Typ.	Max.	Units
V _{dd}	Supply voltage		1.7	1.8	1.9	V
I _{typ-noDE}	Active current consumption @ DE=0	(5Gbps, compliance test pattern, De-emph=0dB and OS = 1.1V)		110	145	mA
I _{typ-WithDE}	Active current consumption @ DE=-3.5dB	(5Gbps, compliance test pattern, De-emph=-3.5dB and OS = 1.1V)		130	165	
I _{U1}	Current consumption @ U1	U1 Power - saving state		14	25	
I _{U2/U3}	Current consumption @ U2/U3	U2/U3 Power - saving state		0.3	1	
I _{pd}	Current consumption @ Power down	Power down state SEL="Float"		0.1	0.4	
I _{unplug}	Current consumption @ Unplug	No USB connection state		0.3	1	

AC/DC Electrical Characteristics Cont.

Symbol	Parameter	Conditions	Min.	Typ.	Max.	Units
Receiver AC/DC						
$V_{RX-DIFFP-P}$	Differential Peak-to-Peak Input Voltage	AC coupled differential RX peak to peak signal	150		1200	mVppd
V_{RX-C}	Common Mode Voltage			1		V
V_{cm_ac}	RX AC Common Mode Voltage	Measured at Rx pins with termination enabled			150	mV
Z_{CM_RX}	DC common mode impedance		18		30	Ω
Z_{diff_RX}	DC differential input impedance		70		120	
$Z_{CM_RX_HIZ}$	DC common mode high impedance	Device in unplug mode RX termination measured with respect to AC GND over 500mV max	25			k Ω
$RL_{RX-DIFF}$	Differential return loss	50 MHz-1.25GHz		21		dB
		1.25 GHz-2.5 GHz		13		
RL_{RX-CM}	Common mode return loss	50 MHz-2.5 GHz		7		dB
$V_{th_U0/U1}$	Input threshold voltage in U0/U1 modes	In U0/U1 mode	50		150	mVppd
V_{th_upm}	LFPS input threshold voltage in no USB connection state	For the path that the receiver termination is not detected. (Notes: uses $V_{th_U2/U3}$ for the path that the receiver termination is detected)	150		650	mVppd
$V_{th_U2/U3}$	LFPS input threshold voltage in U2/U3 modes	In U2/U3 modes	150		650	
Transmitter Output AC/DC (100Ω differential)						
$V_{TX-DIFFP-P}$	Differential Peak-to-peak Output Voltage	$V_{TX-DIFFP-P} = 2 * V_{TX-D+} - V_{TX-D-} $	400		1200	mVppd
$V_{TX-LFPS}$	LFPS Differential Peak-to-peak Output Voltage		800		1200	
V_{TX-C}	Common-Mode Voltage	$ V_{TX-D+} + V_{TX-D-} /2$	0.5		1.2	V
DE	De-emphasis	DE = 0dB		0		dB
		DE = -3.5dB	-3.0	-3.5	-4.0	
Z_{diff_TX}	DC differential impedance		70		120	Ω
Z_{CM_TX}	DC common mode impedance		18		30	
RL_{diff_TX}	Differential return loss	f= 50MHz-1.25 GHz		18		dB
		f= 1.25 GHz-2.5 GHz		12		
RL_{CM_TX}	Common mode return loss	f= 50 MHz-2.5GHz		9		dB
$V_{TX_CM_AC_Active}$	TX AC common mode voltage active			30	100	mVpp

AC/DC Electrical Characteristics Cont.

Symbol	Parameter	Conditions	Min.	Typ.	Max.	Units
V _{detect}	Voltage change to allow receiver detect	Positive voltage to sense receiver termination			600	mV
t _{R,tF}	Output rise/fall time	20%-80% of differential voltage measured 1" from the output pin		60		ps
T _{diff_LH} , T _{diff_HL}	Differential propagation delay	Propagation delay between 50% level at input and output		460	1000	ps
Jitter Profile						
T _{TX-EYE} ⁽¹⁾⁽²⁾	Total jitter(Tj)	with 36 inch of inputFR4 trace		0.2	0.5	UI ⁽³⁾ P-P
DJ _{TX} ⁽²⁾	Deterministic jitter(Dj)			0.1	0.3	
RJ _{TX} ⁽²⁾⁽⁴⁾	Random jitter(Rj)			0.09	0.2	

Note:

- 1.Includes RJ at 10⁻¹² BER
- 2.Deterministic jitter measured with PRBS7 pattern, Random jitter measured with 1010 pattern VID=1000mVpp, 5Gbps,
- 3.UI = 200ps
- 4.Rj calculated as 14.069 times the RMS random jitter for 10⁻¹² BER

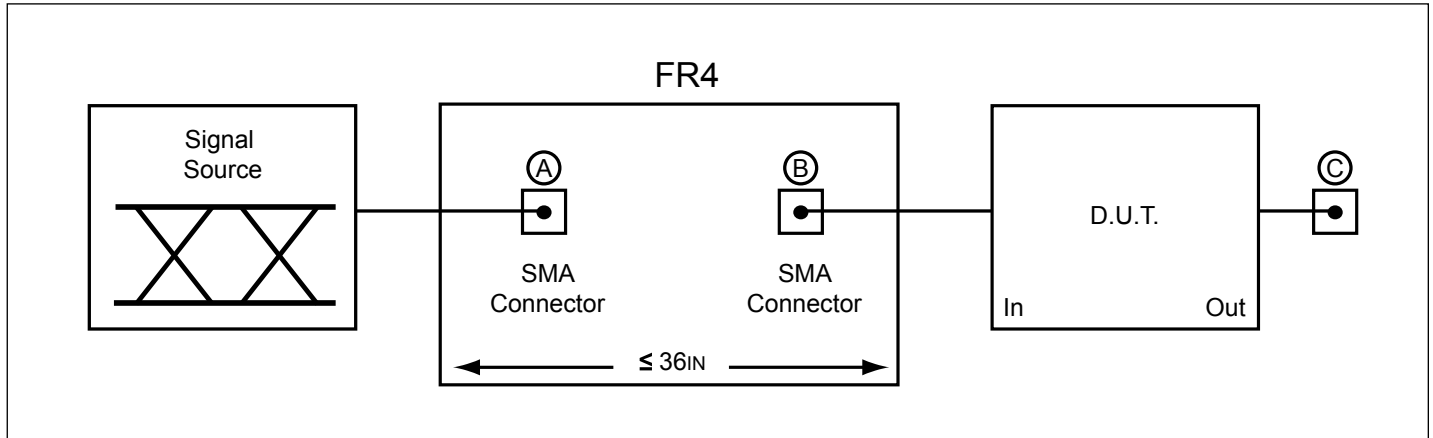

Test Condition Referenced in the Electrical Characteristic Table

Application Schematics

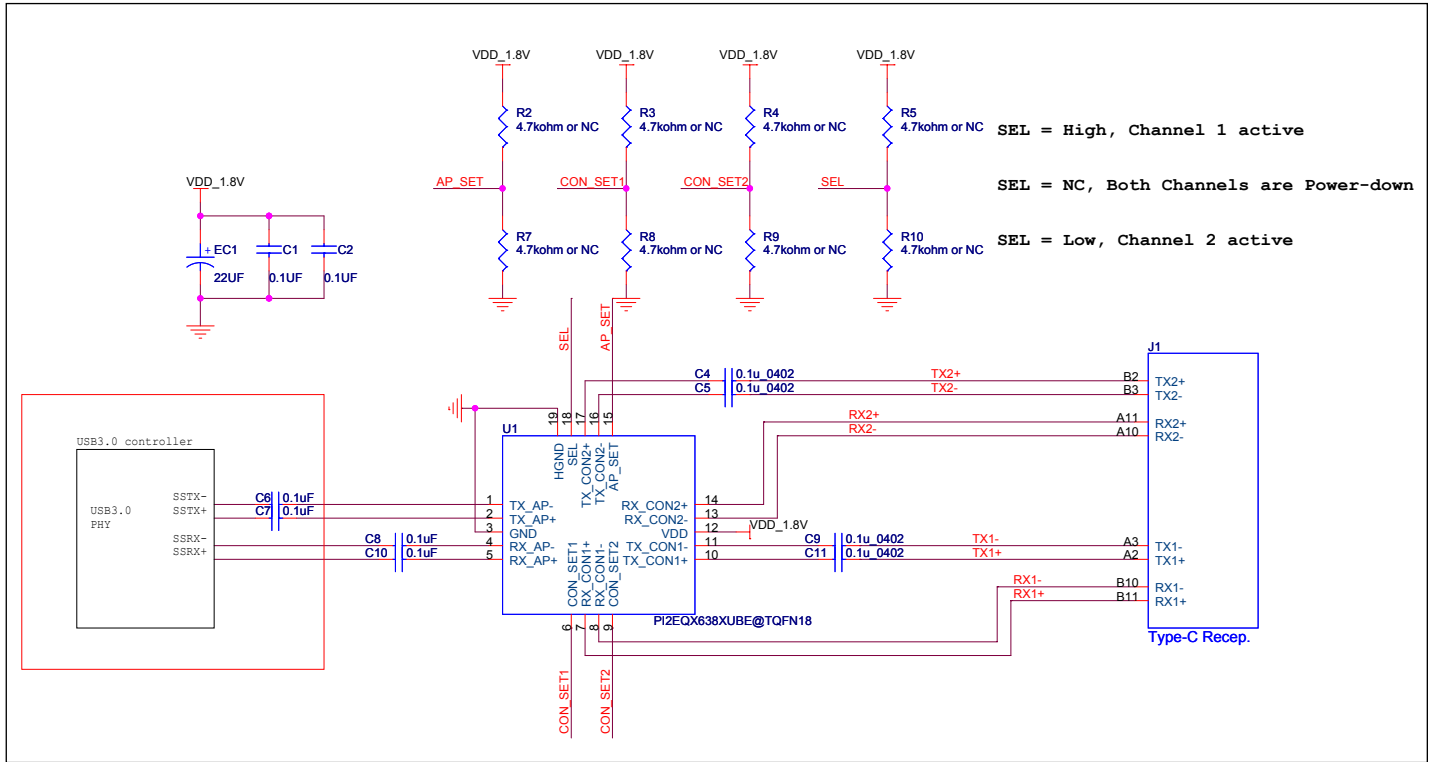

Part Marking

XUB Package

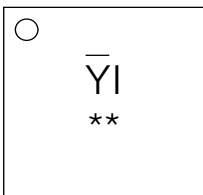

YI: Device name (Top Mark)
 1st * of 2nd line: 2nd letter of Option Code
 2nd * of 2nd line: 1st letter Datecode

PI2EQX638

Packaging Mechanical: 18-X2QFN (XUB)

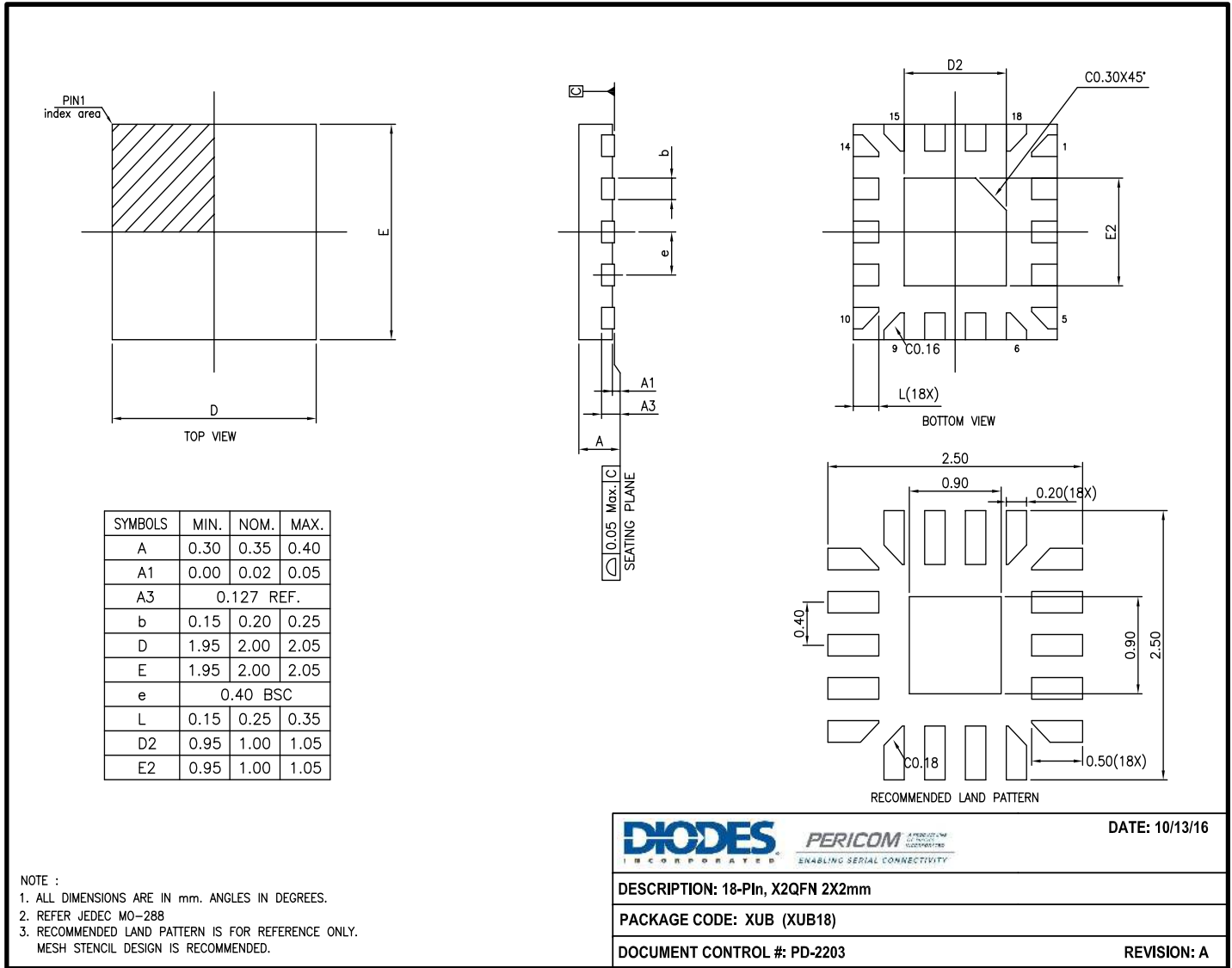

For latest package info.

please check: <http://www.diodes.com/design/support/packaging/pericom-packaging/packaging-mechanicals-and-thermal-characteristics/>

Ordering Information

Ordering Number	Package Code	Package Description
PI2EQX638XUBEX	XUB	18-pin, 2x2mm (X2QFN)

Notes:

1. No purposely added lead. Fully EU Directive 2002/95/EC (RoHS), 2011/65/EU (RoHS 2) & 2015/863/EU (RoHS 3) compliant.
2. See <https://www.diodes.com/quality/lead-free/> for more information about Diodes Incorporated's definitions of Halogen- and Antimony-free, "Green" and Lead-free.
3. Halogen- and Antimony-free "Green" products are defined as those which contain <900ppm bromine, <900ppm chlorine (<1500ppm total Br + Cl) and <1000ppm antimony compounds.
4. E = Pb-free and Green
5. X suffix = Tape/Reel

IMPORTANT NOTICE

DIODES INCORPORATED MAKES NO WARRANTY OF ANY KIND, EXPRESS OR IMPLIED, WITH REGARDS TO THIS DOCUMENT, INCLUDING, BUT NOT LIMITED TO, THE IMPLIED WARRANTIES OF MERCHANTABILITY AND FITNESS FOR A PARTICULAR PURPOSE (AND THEIR EQUIVALENTS UNDER THE LAWS OF ANY JURISDICTION).

Diodes Incorporated and its subsidiaries reserve the right to make modifications, enhancements, improvements, corrections or other changes without further notice to this document and any product described herein. Diodes Incorporated does not assume any liability arising out of the application or use of this document or any product described herein; neither does Diodes Incorporated convey any license under its patent or trademark rights, nor the rights of others. Any Customer or user of this document or products described herein in such applications shall assume all risks of such use and will agree to hold Diodes Incorporated and all the companies whose products are represented on Diodes Incorporated website, harmless against all damages.

Diodes Incorporated does not warrant or accept any liability whatsoever in respect of any products purchased through unauthorized sales channel.

Should Customers purchase or use Diodes Incorporated products for any unintended or unauthorized application, Customers shall indemnify and hold Diodes Incorporated and its representatives harmless against all claims, damages, expenses, and attorney fees arising out of, directly or indirectly, any claim of personal injury or death associated with such unintended or unauthorized application.

Products described herein may be covered by one or more United States, international or foreign patents pending. Product names and markings noted herein may also be covered by one or more United States, international or foreign trademarks.

This document is written in English but may be translated into multiple languages for reference. Only the English version of this document is the final and determinative format released by Diodes Incorporated.

LIFE SUPPORT

Diodes Incorporated products are specifically not authorized for use as critical components in life support devices or systems without the express written approval of the Chief Executive Officer of Diodes Incorporated. As used herein:

A. Life support devices or systems are devices or systems which:

1. are intended to implant into the body, or

2. support or sustain life and whose failure to perform when properly used in accordance with instructions for use provided in the labeling can be reasonably expected to result in significant injury to the user.

B. A critical component is any component in a life support device or system whose failure to perform can be reasonably expected to cause the failure of the life support device or to affect its safety or effectiveness.

Customers represent that they have all necessary expertise in the safety and regulatory ramifications of their life support devices or systems, and acknowledge and agree that they are solely responsible for all legal, regulatory and safety-related requirements concerning their products and any use of Diodes Incorporated products in such safety-critical, life support devices or systems, notwithstanding any devices- or systems-related information or support that may be provided by Diodes Incorporated. Further, Customers must fully indemnify Diodes Incorporated and its representatives against any damages arising out of the use of Diodes Incorporated products in such safety-critical, life support devices or systems.

Copyright © 2016, Diodes Incorporated

www.diodes.com