

Ultra Low Power Wi-Fi® Modules

For Battery Powered IoT Applications

DA16200 Modules

Full Offload Highly Integrated Ultra Low Power Wi-Fi Modules

- The fully integrated module consists of the DA16200 SoC, 4MB flash memory, RF components including crystal oscillator, RF lumped filter, and either a chip antenna or a connector for an external antenna
- Single power supply voltage (3.3V)
- 37 pins including GPIOs, JTAG, RTC control, UART, power input, and 32.768kHz crystal
- DA16200 module SKUs:
 - DA16200MOD-AAC4WA32 with on board chip antenna
 - DA16200MOD-AAE4WA32 with external antenna connector (u.FL)
- Dimensions
 - Both modules have the same dimensions
 - 13.8 mm x 22.1 mm x 3.3 mm



Module Types

On Board Chip Antenna
13.8 mm x 22.1 mm x 3.3 mm
DA16200MOD-AAC4WA32



External Antenna Connector (u.FL)
13.8 mm x 22.1 mm x 3.3 mm
DA16200MOD-AAE4WA32



Block Diagram (SoC)

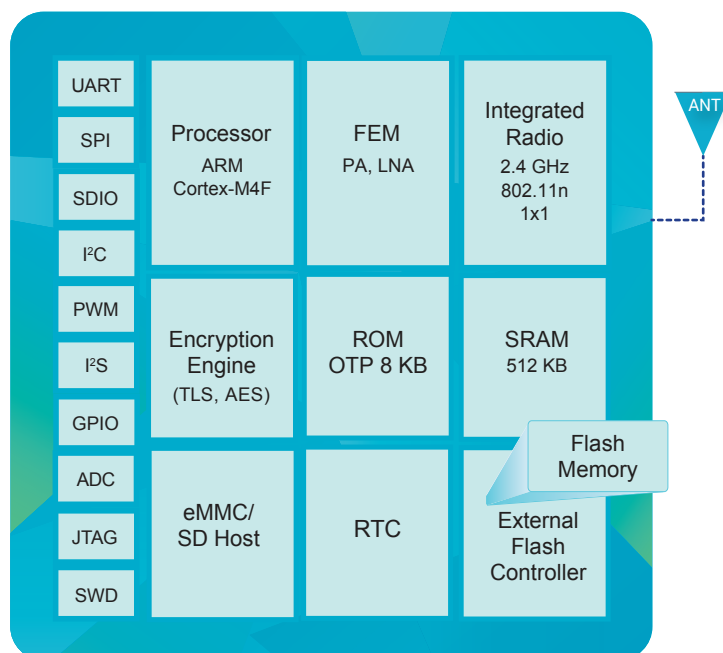

Country	On Board Chip Antenna	External Antenna Connector (u.FL)
US FCC	2AU49-DA16200MC	2AU49-DA16200ME
Canada IC	25650-DA16200MC	25650-DA16200ME
EU CE	CE & RoHS Compliance	CE & RoHS Compliance
South Korea KC	R-C-fci-DA16200M-C4WA3	R-C-fci-DA16200M-E4WA3
Japan TELEC	201-190886	201-190892
China SRRC	2020DP0489	2020DJ0161(M)



Low Power Wi-Fi Modules For Battery Powered IoT Applications

Features	Benefits
Ultra Low Power	<ul style="list-style-type: none"> • Breakthrough VirtualZero™ technology • Virtually no power consumption in sleep state • Enables year-plus battery life • Ultra low power sensor wake-up
Superior Range	<ul style="list-style-type: none"> • Industry leading output power and Rx sensitivity for max range
Highly Integrated SoC	<ul style="list-style-type: none"> • 802.11b/g/n radio PHY, BB/MAC, PA, LNA w/on chip SRAM • Up to 72 Mbps, MCS0-7
Full Offload	<ul style="list-style-type: none"> • SoC runs full OS & TCP/IP stack
Simple Setup & Provisioning	<ul style="list-style-type: none"> • Automatically find & configure new devices w/ smartphone app
Complete Software Stack	<ul style="list-style-type: none"> • Comprehensive networking software stack
Leading Security	<ul style="list-style-type: none"> • Secure boot • Secure debug • Secure asset storage • Hardware accelerated • TLS • Digital certificates • Elliptic curve
OTA Firmware Update	<ul style="list-style-type: none"> • Enables field deployed device firmware updates
Multiple I/Os	<ul style="list-style-type: none"> • UART, SPI, SDIO, ADC, I²C, PWM, I²S, GPIOs, JTAG and SWD
eMMC/SD Expanded Memory	<ul style="list-style-type: none"> • Data logging, memory intensive applications

VirtualZero™ Leading Edge Low Power Technology



> 1 Year Battery Life



Three Sleep Modes

1. Unconnected (nanoamp)
2. Connected ultra low (microamp)
3. Connected ultra fast (microamp)



**Ultra Fast Wake-up
Ultra Fast Return to Sleep**
Extends battery life

Additional Features



Extended Range

- > +20 dBm range booster mode
- > -100 dBm Rx sensitivity



Highly Integrated SoC

- + No CPU or MCU required
- + Full offload
- + Runs network stack

Networking Capabilities	Protocols	Complete software stack including TCP/UDP/IP, HTTP, HTTPs, DHCP client/server, DNS client/server, mDNS, DNS-SD, MQTT, CoAP
	Provisioning	Included smartphone app for iOS & Android; WPS 2.0
	Sensors	ADC: 4-channel SAR 12-bit, I ² C, SPI, PWM, and I ² S



Dialog Semiconductor Worldwide Sales Offices

www.dialog-semiconductor.com email: info@diasemi.com

United Kingdom
Phone: +44 1793 757 700

The Netherlands
Phone: +31 73 640 8822

Japan
Phone: +81 3 5769 5100

Hong Kong
Phone: +852 3769 5200

China (Shenzhen)
Phone: +86 755 2981 3669

Germany
Phone: +49 7021 8050

North America
Phone: +1 408 845 8500

Taiwan
Phone: +886 2 80718888

Korea
Phone: +82 2 3469 8200

China (Shanghai)
Phone: +86 21 5424 9058

This publication is issued to provide outline information only, which unless agreed by Dialog Semiconductor may not be used, applied, or reproduced for any purpose or be regarded as a representation relating to products. All use of Dialog Semiconductor products, software and applications referred to in this document are subject to Dialog Semiconductor's Standard Terms and Conditions of Sale, available on the company website (www.dialogsemiconductor.com) unless otherwise stated.

Dialog and the Dialog logo are trademarks of Dialog Semiconductor plc or its subsidiaries. All other product or service names are the property of their respective owners. © Copyright 2020 Dialog Semiconductor. All rights reserved.

