

# BP-DAC11001EVM

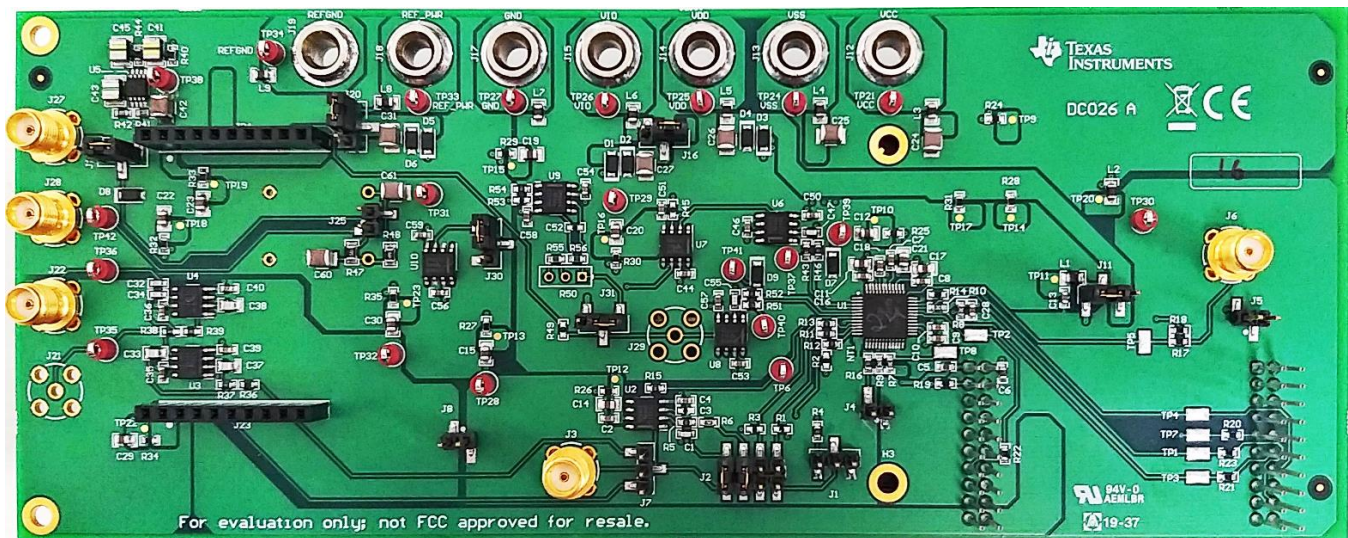

This user's guide describes the characteristics, operation, and use of the BP-DAC11001 evaluation module (EVM) BoosterPack™ plug-in module. This EVM is designed to evaluate the performance of the [DAC11001](#) buffered voltage output DAC in a variety of configurations. Throughout this document, the terms evaluation board, evaluation module, and EVM are synonymous with the BP-DAC11001EVM. This document includes a schematic, reference printed-circuit board (PCB) layouts, and a complete bill of materials.

## Contents

1	Overview .....	3
1.1	Kit Contents .....	3
1.2	Related Documentation from Texas Instruments .....	3
2	System Setup .....	4
2.1	Software Setup .....	4
2.2	Hardware Setup .....	6
3	Detailed Description .....	8
3.1	Hardware Description .....	8
3.2	Software Description .....	10
4	Schematic, PCB Layout, and Bill of Materials .....	16
4.1	BP-DAC11001EVM Schematic .....	16
4.2	PCB Layout .....	20
4.3	BP-DAC11001EVM Bill of Materials .....	23

## List of Figures

1	BP-DAC11001EVM Software Setup .....	4
2	Software Installation Path .....	4
3	Launchpad Setup .....	5
4	TI Cloud Agent Installation .....	5
5	Hardware Setup .....	6

6	BP-DAC11001EVM Hardware Block Diagram .....	8
7	Launchpad Interface Pinout .....	9
8	BP-DAC11001EVM GUI Location.....	10
9	GUI Connection Detection .....	10
10	Software Home Page .....	11
11	Setup Page.....	12
12	DAC Quick-Start Page: Basic DAC Tab .....	13
13	Register Map Page .....	14
14	Register Page Options .....	14
15	Collateral Page .....	15
16	Schematic Page 1 .....	16
17	Schematic Page 2.....	17
18	Schematic Page 3.....	18
19	Schematic Page 4.....	19
20	PCB Components: Top Overlay .....	20
21	PCB Components: Bottom Overlay .....	20
22	PCB Layout: Top Layer .....	21
23	PCB Layout: Ground Plane .....	21
24	PCB Layout: Power Plane .....	22
25	PCB Layout: Bottom Layer.....	22

#### List of Tables

1	Kit Contents .....	3
2	Required Components Not Included With Kit .....	3
3	Related Documentation .....	3
4	BP-DAC11001EVM Power Supply Inputs .....	7
5	BP-DAC11001EVM Jumper Settings .....	7
6	BP-DAC11001EVM Bill of Materials .....	23

#### Trademarks

BoosterPack is a trademark of Texas Instruments Inc.  
Windows is a trademark of Microsoft Corporation.  
All other trademarks are the property of their respective owners.

## 1 Overview

The BP-DAC11001EVM is an easy-to-use platform to evaluate the functionality and performance of the DAC11001 device. The DAC11001 is a highly accurate, low-noise, voltage-output, single-channel, digital-to-analog converter (DAC). The DAC11001 is specified monotonic by design, and offers excellent linearity of less than 4 LSB (max) across all ranges.

The unbuffered voltage output offers low-noise performance ( $7 \text{ nV}/\sqrt{\text{Hz}}$ ) in combination with fast settling time ( $1 \mu\text{s}$ ), making this device an excellent choice for low-noise, high-speed applications. The DAC11001 integrates an enhanced deglitch circuit with range- and code-independent symmetrical ultra-low glitch ( $1.5 \text{ nV-s}$ ) to enable clean waveform ramps with ultra-low harmonic distortion (THD).

The DAC11001 device incorporates a power-on-reset (POR) circuit so that the DAC powers on with known values in the registers. With external references, DAC output ranges from  $V_{\text{REFPF}}$  to  $V_{\text{REFNF}}$  can be achieved, including asymmetric output ranges.

The DAC11001 uses a versatile 4-wire serial interface that operates at clock rates of up to 50 MHz. The DAC11001 is specified over the industrial temperature range of  $-40^{\circ}\text{C}$  to  $+125^{\circ}\text{C}$ .

The EVM provides the GPIO and SPI programming interface using a PC-based graphical user interface (GUI). This EVM requires the MSP-EXP432E401Y Launchpad for interfacing with the PC-based GUI.

### 1.1 Kit Contents

Table 1 details the contents of the EVM kit. Contact the TI Product Information Center nearest you if any component is missing. TI highly recommends that the user verify latest versions of the related software at the TI website, [www.ti.com](http://www.ti.com).

**Table 1. Kit Contents**

Item	Quantity
BP-DAC11001EVM BoosterPack	1

**Table 2. Required Components Not Included With Kit**

Item	Quantity
MSP-EXP432E401Y Launchpad	1

The MSP-EXP432E401Y Launchpad can be purchased from the [MSP432E401Y tool folder](#) on [www.ti.com](http://www.ti.com).

### 1.2 Related Documentation from Texas Instruments

The following document provides information regarding Texas Instruments integrated circuits used in the assembly of the BP-DAC11001EVM. This user's guide is available from the TI web site under literature number SLAU806. Any letter appended to the literature number corresponds to the document revision that is current at the time of the writing of this document. Newer revisions may be available from the TI web site at <http://www.ti.com/>, or call the Texas Instruments Literature Response Center at (800) 477-8924 or the Product Information Center at (972) 644-5580. When ordering, identify the document by both title and literature number.

**Table 3. Related Documentation**

Document	Literature Number
<a href="#">DAC11001</a> product data sheet	<a href="#">SLASEL0</a>

## 2 System Setup

### 2.1 Software Setup

This section provides the procedure for EVM software installation.

#### 2.1.1 Software Installation

The EVM software is compatible with the Windows™ 7, 8, and 10 operating systems. The software is available on the product folder, and can also be found in the [GUI Composer Gallery](#). Search for *BP-DAC11001EVM* in the GUI Composer Gallery. Use the down arrow symbol to download the software. There are two downloads: *BP-DAC11001EVM GUI* and *GUI Composer Runtime*. Either download both, or just download the EVM GUI; the runtime file can be downloaded through the EVM GUI during installation. The software can also be run online; however, only after the firmware and driver are upgraded. After the software is downloaded onto the PC, navigate to the download folder, and run the BP-DAC11001EVM software executable, as shown in [Figure 1](#).



**Figure 1. BP-DAC11001EVM Software Setup**

When the BP-DAC11001EVM software is launched, an installation dialog window opens and prompts the user to select an installation directory. If left unchanged, the software location defaults to *C:\Program Files (x86)\Texas Instruments\BP-DAC11001 EVM*, as shown in [Figure 2](#). If there is no previous installation of the *GUI Composer Runtime* application, the installer also requests for an automatic download from the web. Select either *Install from Web* to download and install from the web, or *Install from PC* and provide the path to the local file that is already downloaded. The runtime executable also installs the USB drivers, unless the drivers are already installed.

The software installation automatically copies the required files and drivers to the local machine.

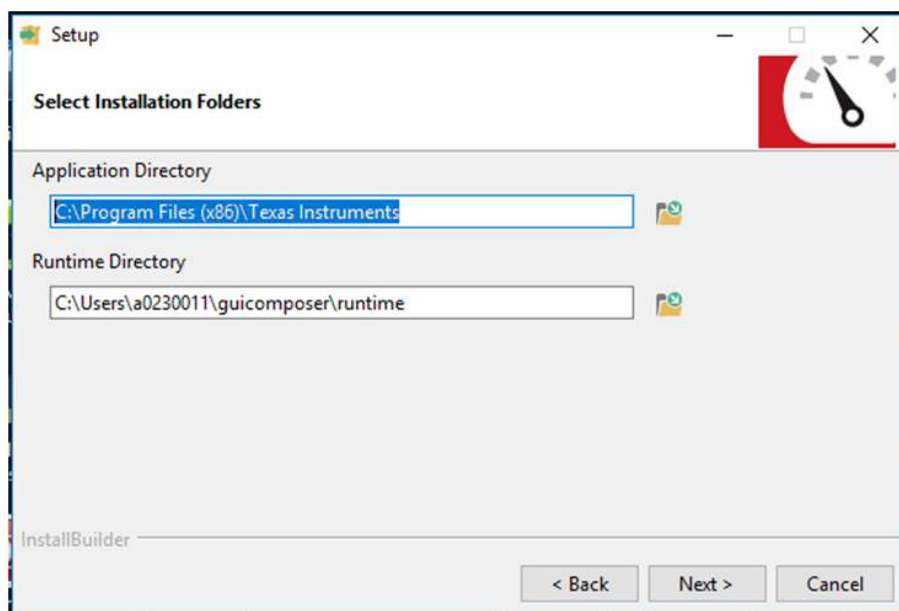

**Figure 2. Software Installation Path**

### 2.1.2 Launchpad Firmware Upgrade

Before using the software for the first time, upgrade the firmware for the launchpad. The firmware is programmed to the launchpad using the online tool, [UniFlash](#). This link is also provided on the *Setup* page of the GUI. After unzipping the *install\_image\_BP-DAC11001EVM.zip* file, the firmware bin file is found at `<Download Directory>\BP-DAC11001EVM_1.0.1_installer_win\install_image_BP-DAC11001EVM\BP-DAC11001EVM\firmware\acctrl.bin`.

Follow the step-by-step procedure below to upgrade the firmware and install the device drivers successfully:

1. Remove jumper JP6 on the launchpad, as shown in step 1 of [Figure 3](#).

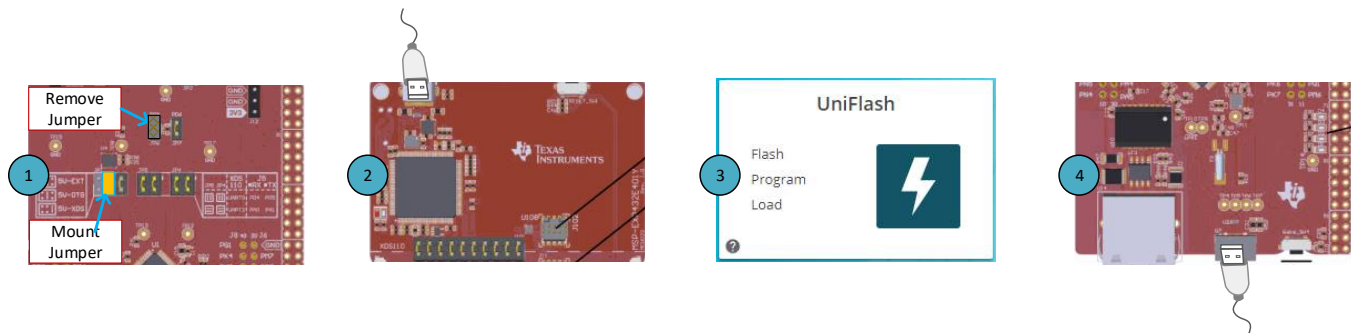

**Figure 3. Launchpad Setup**

2. Mount the jumper on 5V-OTG. Retain the jumper on 5V-XDS, as shown in step 1 of [Figure 3](#).
3. Connect the USB cable to the port on the XDS110 side of the board, as shown in step 2 of [Figure 3](#).
4. Connect the USB cable to PC and open [UniFlash](#). Click on *Start Now* in the *Detect Device* section.
5. If the GUI Composer framework is being installed for the first time on the PC, the browser extension and the *TI Cloud Agent* must also be installed. Follow the 2-step installation flow prompted on the web page, as shown in [Figure 4](#)

### TI Cloud Agent Installation

Hardware interaction requires additional one time set up. Please perform the actions listed below and try your operation again.(What's this?)

- Step 1: **INSTALL** browser extension
- Step 2: **DOWNLOAD** and install the TI Cloud Agent Application
- Help. I already did this

**FINISH**

**Figure 4. TI Cloud Agent Installation**

6. Press the *Refresh* or *Finish* button after the installation is complete. This action should detect the launchpad.
7. Press *Start* and browse for `<Download Directory>\BP-DAC11001EVM_1.0.1_installer_win\install_image_BP-DAC11001EVM\BP-DAC11001EVM\firmware\acctrl.bin`. Press *Load Image* followed by *Verify Image*.

## 2.2 Hardware Setup

This section provides the overall system setup for the EVM. The hardware setup contains the MSP-EXP432E401Y launchpad and the BP-DAC11001EVM. A PC runs the software that provides an interface to the BP-DAC11001EVM through the launchpad.

The BP-DAC11001EVM requires external power supplies, as described later in this document. The 3.3-V and 5-V power supplies from the launchpad can be used for IOVDD and DVDD for the DAC, respectively, using jumper options. The launchpad generates the digital signals used to communicate with the EVM board.

Figure 5 displays the hardware setup.

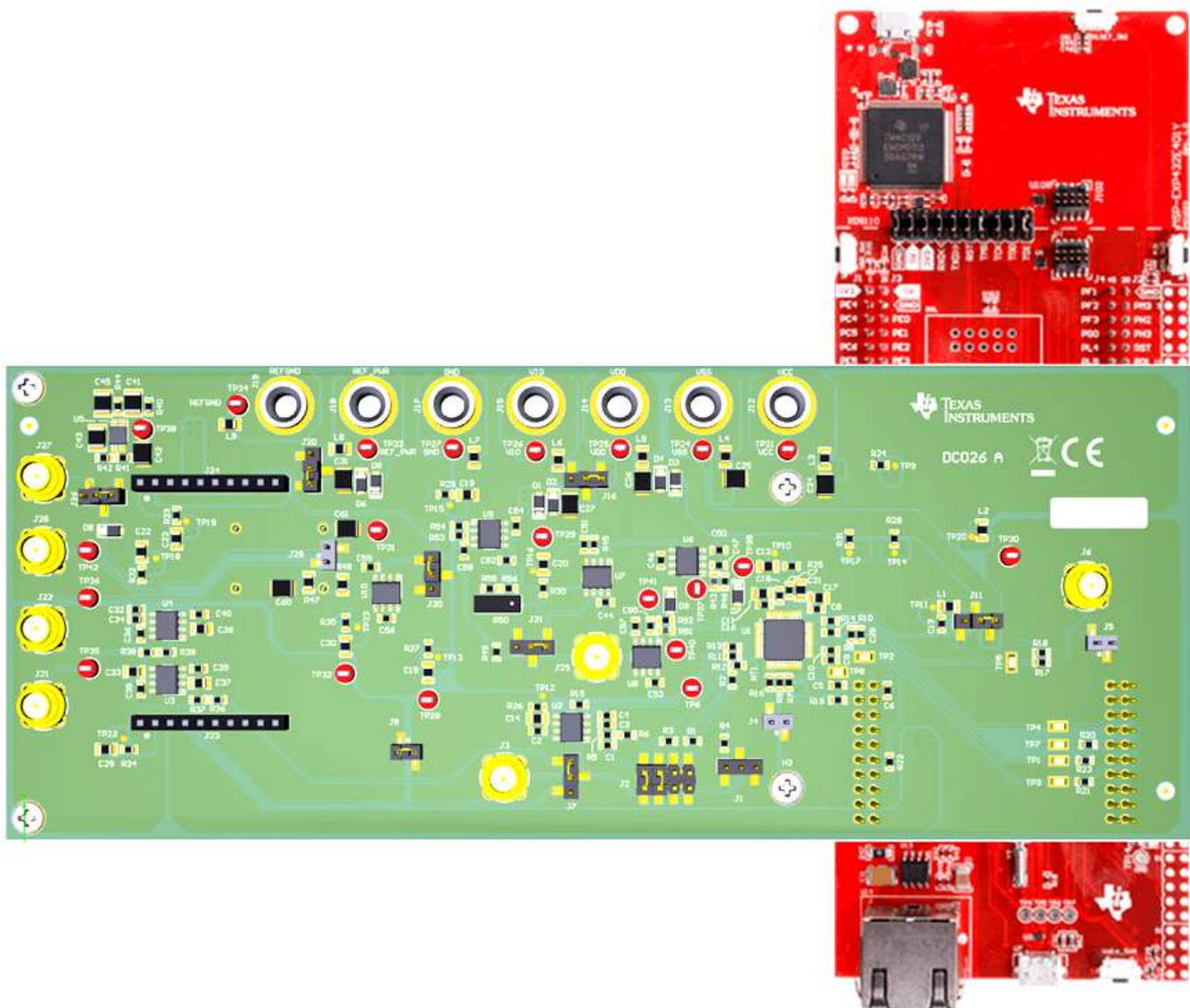

**Figure 5. Hardware Setup**

## 2.2.1 Power Configurations and Jumper Settings

The BP-DAC11001EVM provides electrical connections to the device supply pins. The connectors and optional configurations are shown in [Table 4](#), and [Table 5](#) shows the EVM jumper settings.

**Table 4. BP-DAC11001EVM Power Supply Inputs**

BP-DAC11001EVM Connector	Supply Name	Voltage Range	Test Point
J12	VCC	5 V to 15 V	TP21
J13	VSS	-5 V to -15 V	TP24
J14	VDD	4.5 V to 5.5 V	TP25
J15	VIO	2.7 V to 5.5 V (Option: 3V3 on the launchpad)	TP26
J17	GND	0 V	TP27
J18	REF_PWR	5.3 V to 5.5 V	TP33
J19	REFGND	0 V	TP34

**Table 5. BP-DAC11001EVM Jumper Settings**

Jumper	Description	Default Position	Alternative Position
J1	2x gain configuration	None	1-2 or 2-3
J2	Output amplifier feedback configuration	1-2, 3-4: external resistor and capacitor connection	5-6, 7-8: embedded resistor connection
J4	$\overline{\text{LDAC}}$ pull-down	None	1-2: $\overline{\text{LDAC}}$ tied low
J5	$\overline{\text{CLR}}$ pull-down	None	1-2: $\overline{\text{CLR}}$ tied low
J7	DAC output to load circuit connection	None	1-2: DAC output to auxiliary circuit; 2-3: DAC output to filter input
J8	AGND-OUT to FILTGND connection	None	1-2: AGND-OUT and FILTGND shorted
J11	DVDD connection	2-3: DVDD from AEVM_5V0	1-2: DVDD from VDD
J16	IOVDD connection	2-3: IOVDD from AEVM_3V3	1-2: IOVDD from VIO
J20	REF_PWR connection	2-3: REF_PWR from J18	1-2: REF_PWR from VCC. <b>Make sure VCC is &lt; 6 V before using this option.</b>
J25	Reference filter bypass	None	1-2: Bypass reference filter
J26	Reference source selection	2-3: Onboard reference	1-2: External reference (3 V to 10 V)
J30	REFGND connection	2-3: Through ground buffer	1-2: <b>Do not use on the Rev A PCB</b>
J31	Negative reference selection	2-3: Inverted reference source	1-2: Tied to ground (unipolar output mode)

## 2.2.2 Connecting the Hardware

After the launchpad firmware is upgraded as described in [Section 2.1.2](#), and power and jumper configurations done as per [Section 2.2.1](#), the BP-DAC11001EVM and the launchpad can be connected as shown in [Figure 5](#). Connect the USB cable from the launchpad OTG USB port (U7) to the PC.

## 2.2.3 Electrostatic Discharge Caution

Many of the components on the BP-DAC11001EVM and the launchpad are susceptible to damage by electrostatic discharge (ESD). Observe proper ESD handling precautions when unpacking and handling the EVM, including the use of a grounded wrist strap at an approved ESD workstation.

### 3 Detailed Description

#### 3.1 Hardware Description

The following subsections provide detailed information on the EVM hardware and jumper configuration settings.

##### 3.1.1 Theory of Operation

The block diagram of the BP-DAC11001EVM board is displayed in [Figure 6](#). The dotted lines indicate different power and ground domains. All grounds are shorted together using single-point shorts. The EVM board connects to the launchpad with the BoosterPack connectors. There is an onboard reference, using the [REF6250](#), that generates a 5-V voltage reference, that in turn is converted to 5-V and  $-5$ -V reference inputs for the DAC. There is an option for an external reference using connectors J27 and J28. Both J27 and J28 form a force-sense pair that eliminate cable losses while connected to external reference sources. The DAC output is provided on J3. Jumper J2 provides various feedback options for the output amplifier. The DAC output can be taken through two-stage, second-order filters using connectors J7 and J8. There is an option to interface an external circuit using auxiliary connectors J23 and J24.

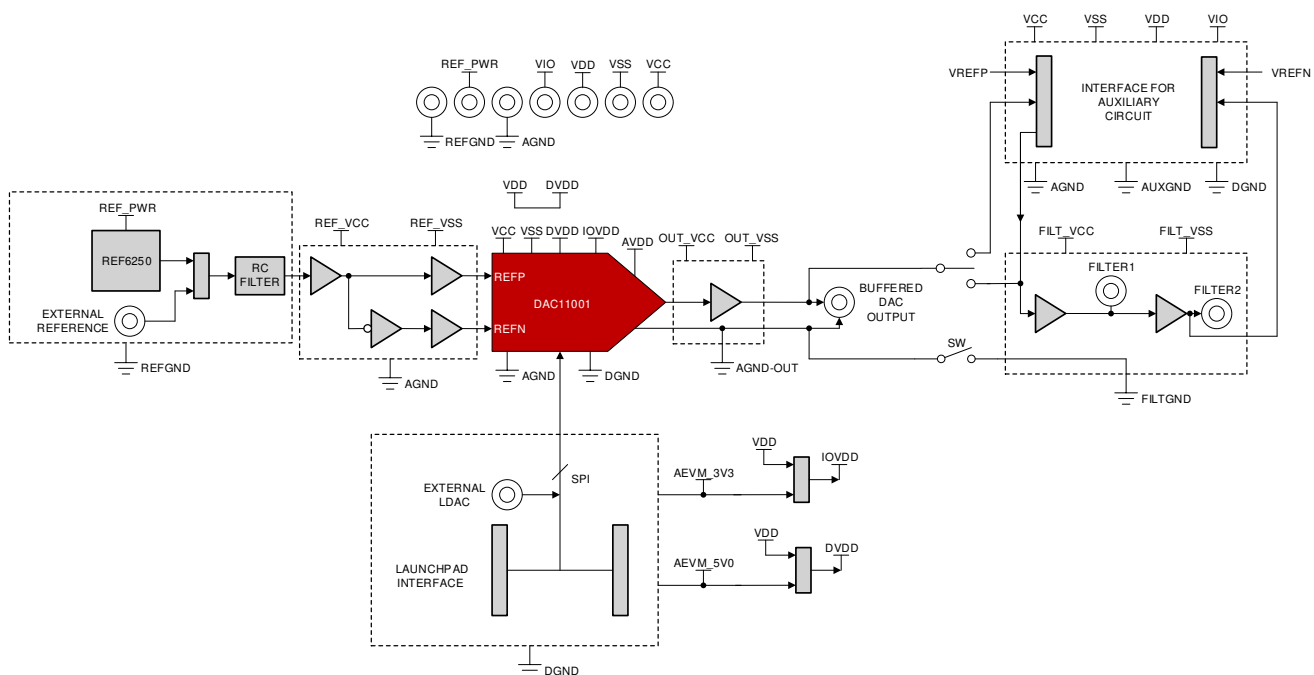

**Figure 6. BP-DAC11001EVM Hardware Block Diagram**





### 3.2 Software Description

This section describes the features of the BP-DAC11001EVM software, and discusses how to use these features. The software provides basic control of all the registers and functions of the DAC11001 device.

#### 3.2.1 Starting the Software

To launch the software, locate the Texas Instruments folder in the *All Programs* menu, and select the *BP-DAC11001EVM* icon, as shown in [Figure 8](#).

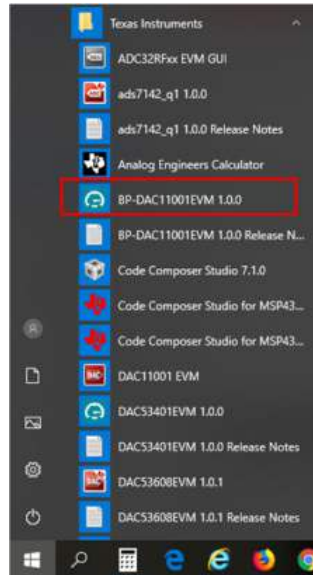

**Figure 8. BP-DAC11001EVM GUI Location**

[Figure 9](#) shows that if the launchpad connector is connected correctly, the status bar at the bottom of the screen displays *Hardware Connected*. If the launchpad is not properly connected or not connected at all, the status bar displays *Hardware not connected*. In case the *Hardware not connected* status persists even after the hardware is connected, go to *Options* → *Serial Port*, and change the port to the other available port with the *(Texas Instruments)* or *ACCtrl* tag. One of the two ports with these tags will connect to the hardware.

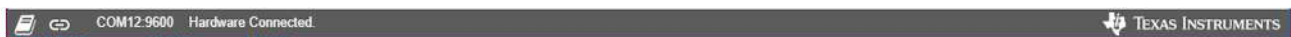

**Figure 9. GUI Connection Detection**

### 3.2.2 Software Features

The BP-DAC11001EVM incorporates interactive functions that help configure the DAC11001 device. These functions are built into several GUI pages, as shown in the following sections. The *Menu* button allows the user to switch between the pages, with each page representing a feature of the software.

#### 3.2.2.1 Home Page

The *Home* page, shown in [Figure 10](#), provides the basic information and navigation to other pages. Click on *Learn More...* to get more information on the device.

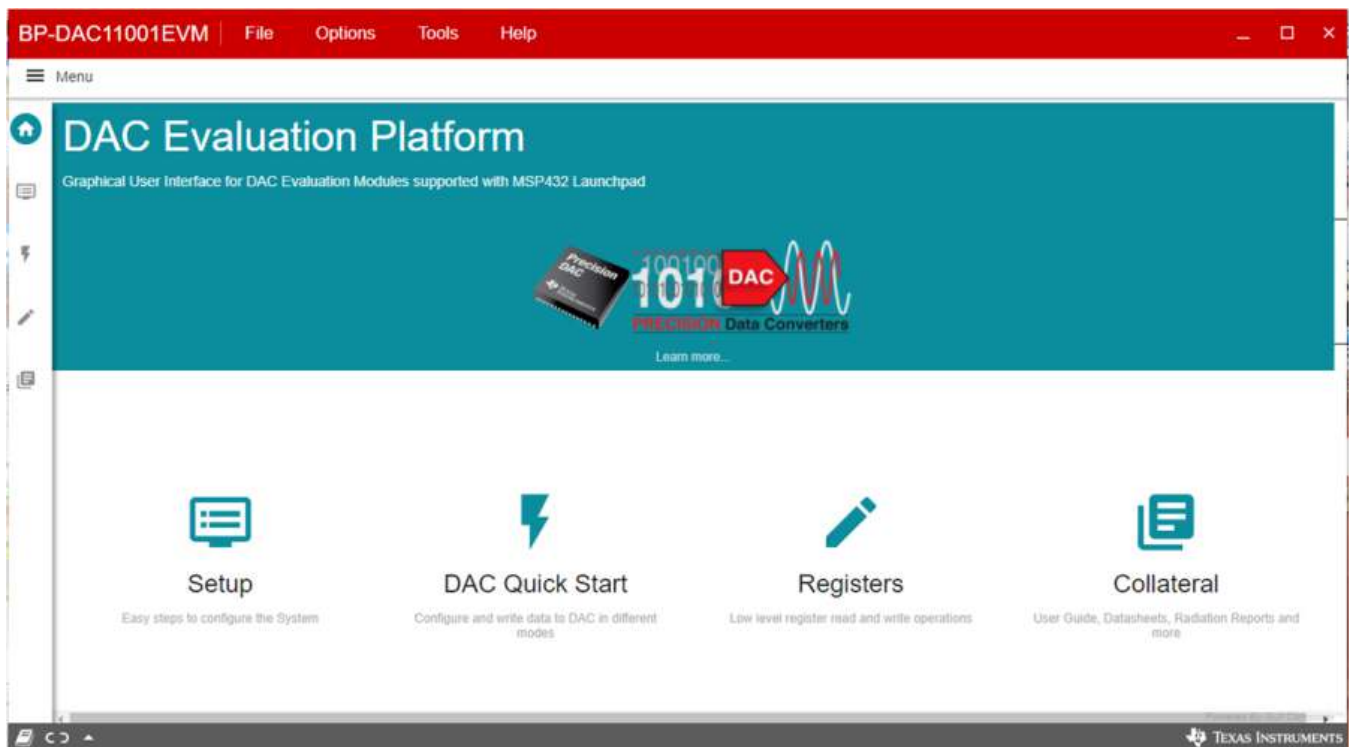

Figure 10. Software Home Page

### 3.2.2.2 Setup Page

The *Setup* page, shown in [Figure 11](#), guides the user to perform a one-time firmware upgrade for the launchpad.

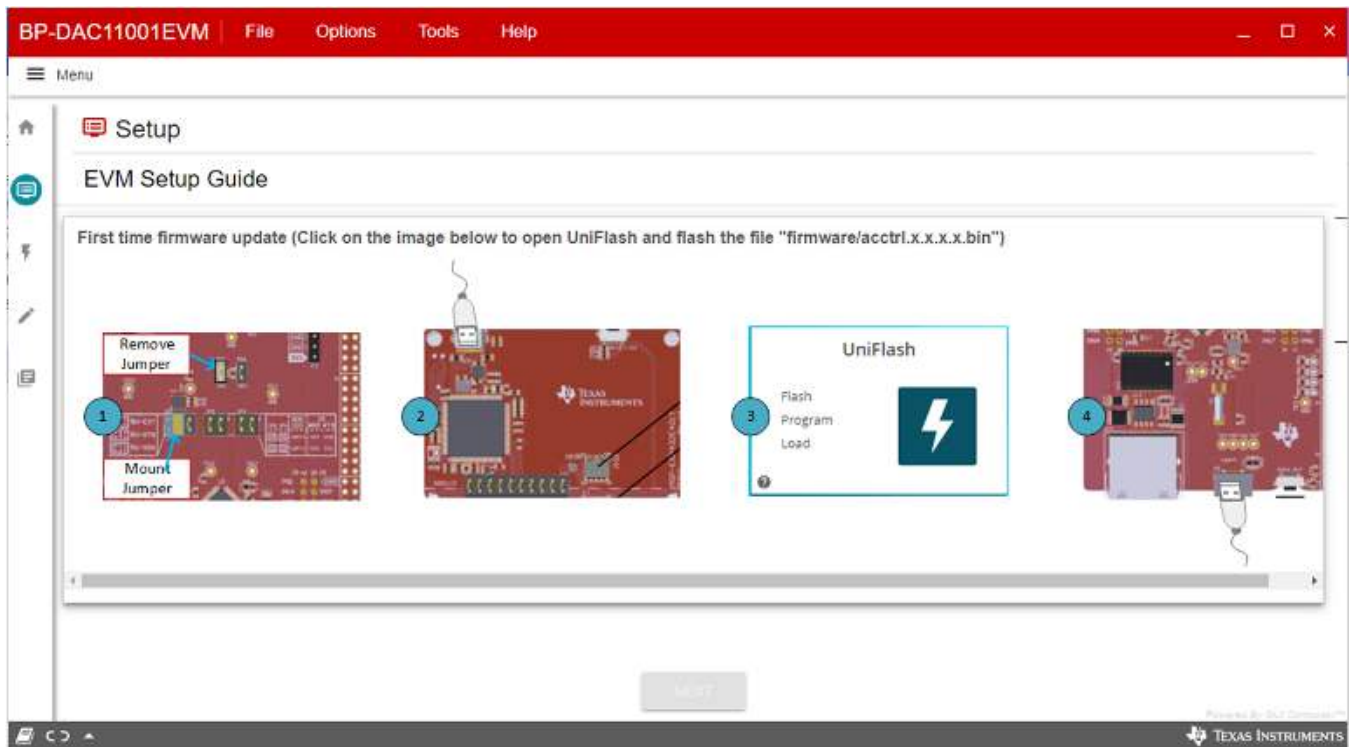

Figure 11. Setup Page

### 3.2.2.3 DAC Quick-Start Page

The *DAC Quick-Start* page provides the functions to quickly get started with the EVM. The basic initialization settings are meant for basic dc operation; whereas, the advanced settings are meant for ac functionality, such as settling time and total harmonic distortion (THD). Write a decimal code to the DAC output input box to get the corresponding analog output.

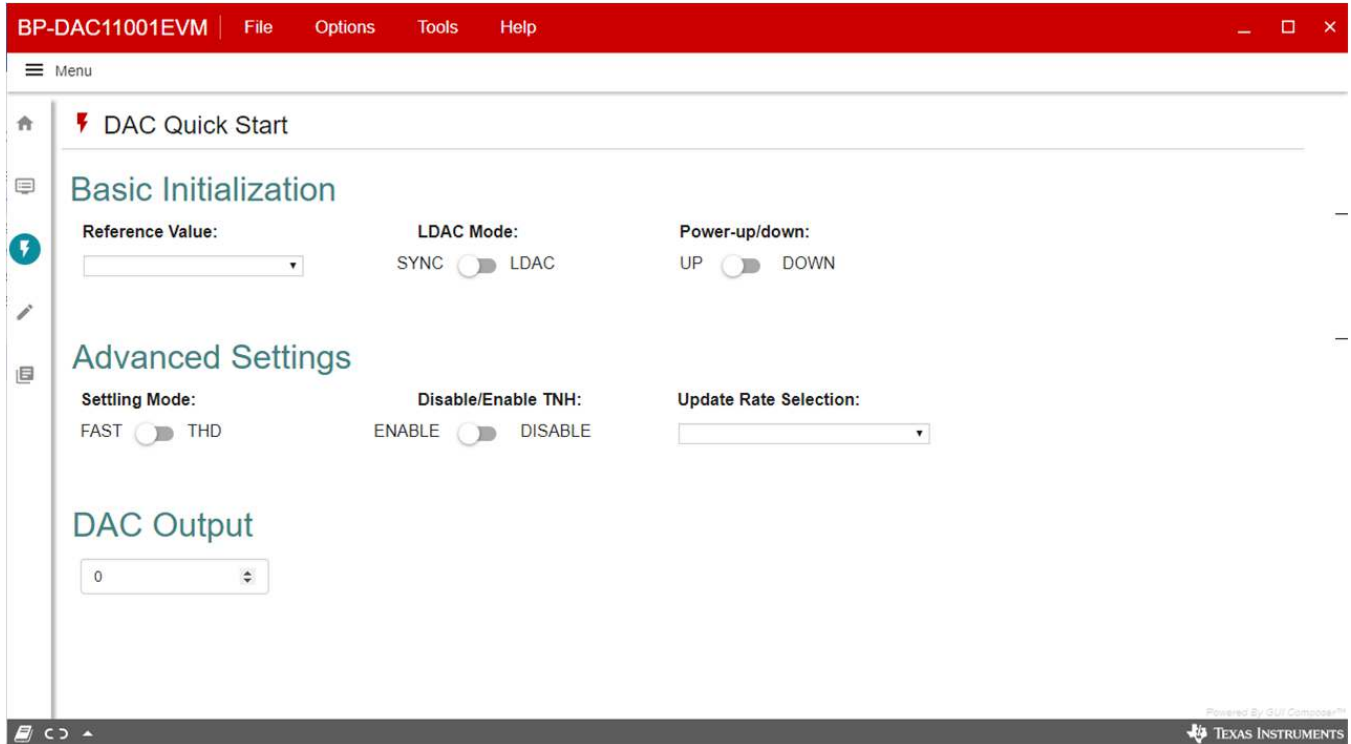

Figure 12. DAC Quick-Start Page: Basic DAC Tab

### 3.2.2.4 Register Map Page

The *Register Map* page, shown in [Figure 13](#), allows the user to access low-level communication directly with the DAC11001 registers. Selecting a register on the *Register Map* list shows a description of the values in that register, as well as information on the register address, default value, size, and current value. Values are read from and written to the registers by writing to the *Value* or bit field of the GUI.

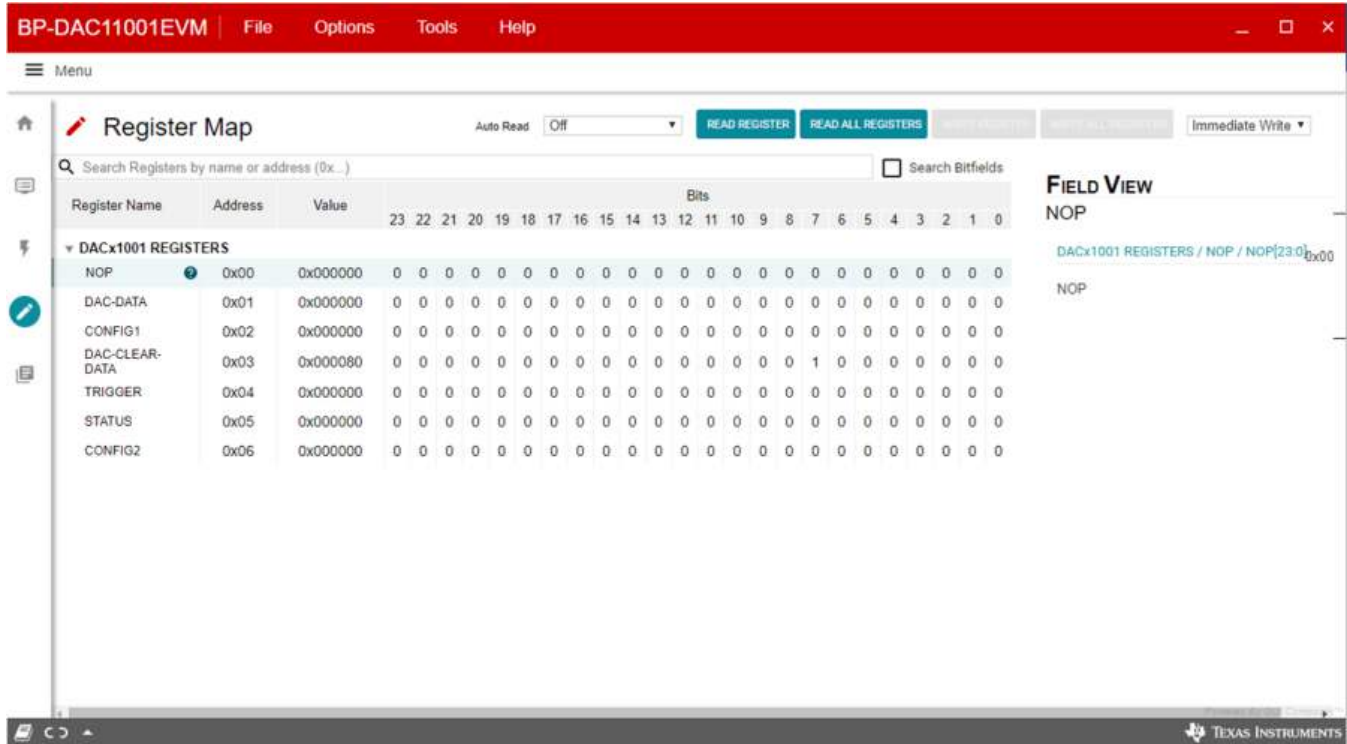

Figure 13. Register Map Page

There are some configuration lists and action buttons provided on the *Register Map* page. To store the values of the register map locally, press the *Save Registers* button under the *File* menu option. Additionally, recall and load the stored configuration files through the *Load Registers* button. Other options selectable by the user are the *Auto Read Interval*, *Read Register*, *Read All Registers*, *Write Register*, *Write All Registers*, and *Update Mode* buttons. These buttons are displayed in [Figure 14](#). The *Write Register* and *Write All Registers* buttons are enabled only with *Deferred* update mode. *Deferred* mode initiates a write operation only when the *Write Register* or the *Write All Registers* button is pressed. By default, the *Immediate* update mode is selected for the *Register Map* page write operations.



Figure 14. Register Page Options

### 3.2.2.5 Collateral Page

This page shown in [Figure 15](#) provides links for all the collateral on the DAC11001 device.

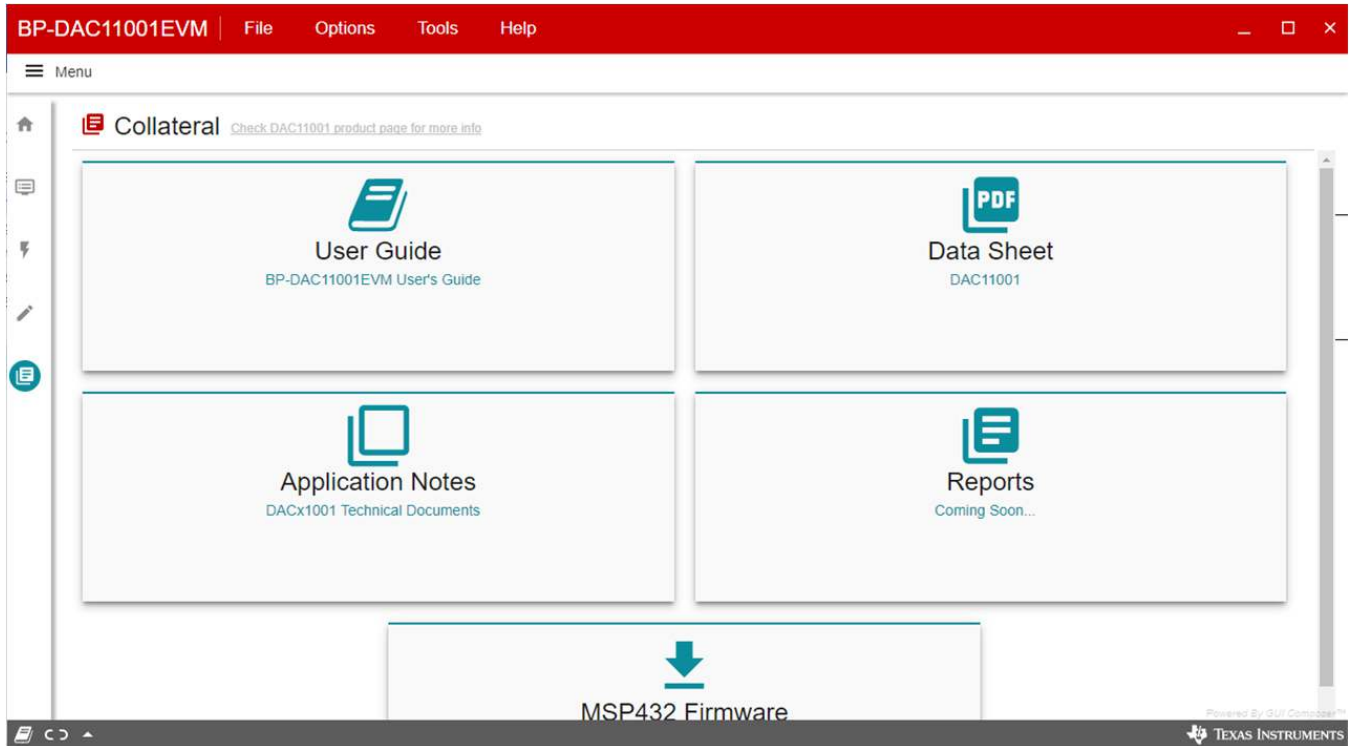

**Figure 15. Collateral Page**

## 4 Schematic, PCB Layout, and Bill of Materials

This section contains the complete bill of materials and schematic diagram for the BP-DAC11001EVM.

### 4.1 BP-DAC11001EVM Schematic

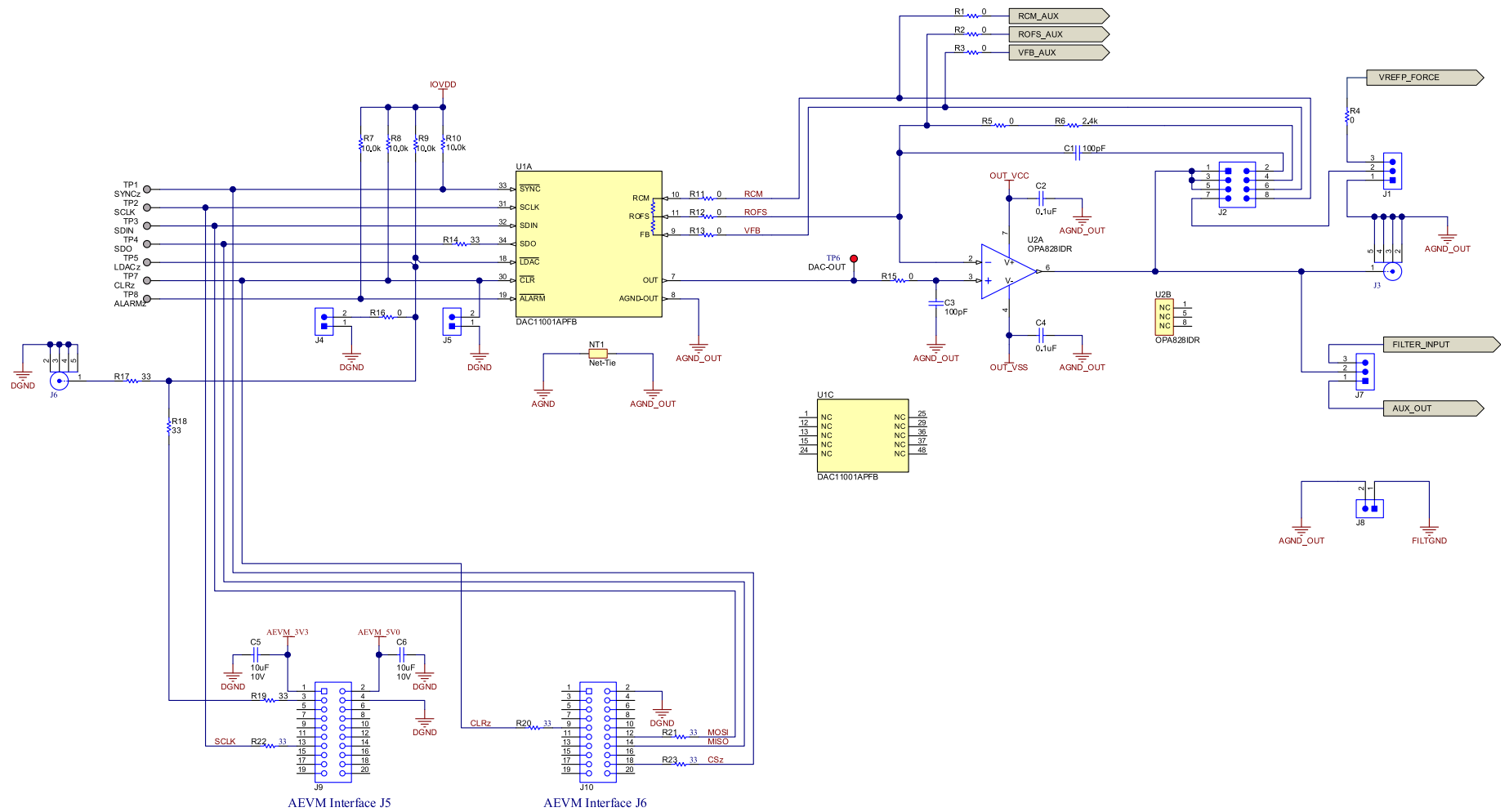

Figure 16. Schematic Page 1





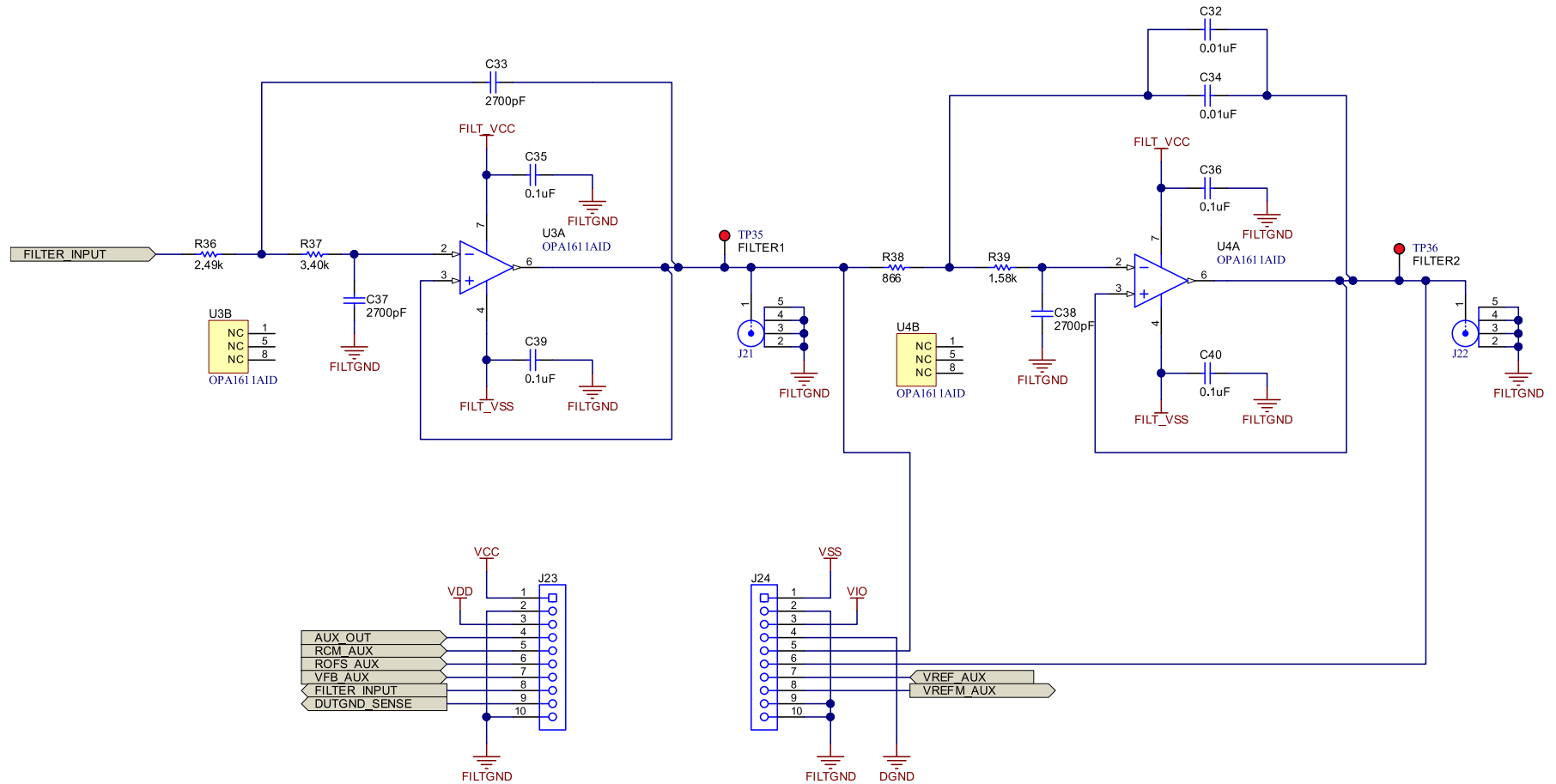

Figure 18. Schematic Page 3

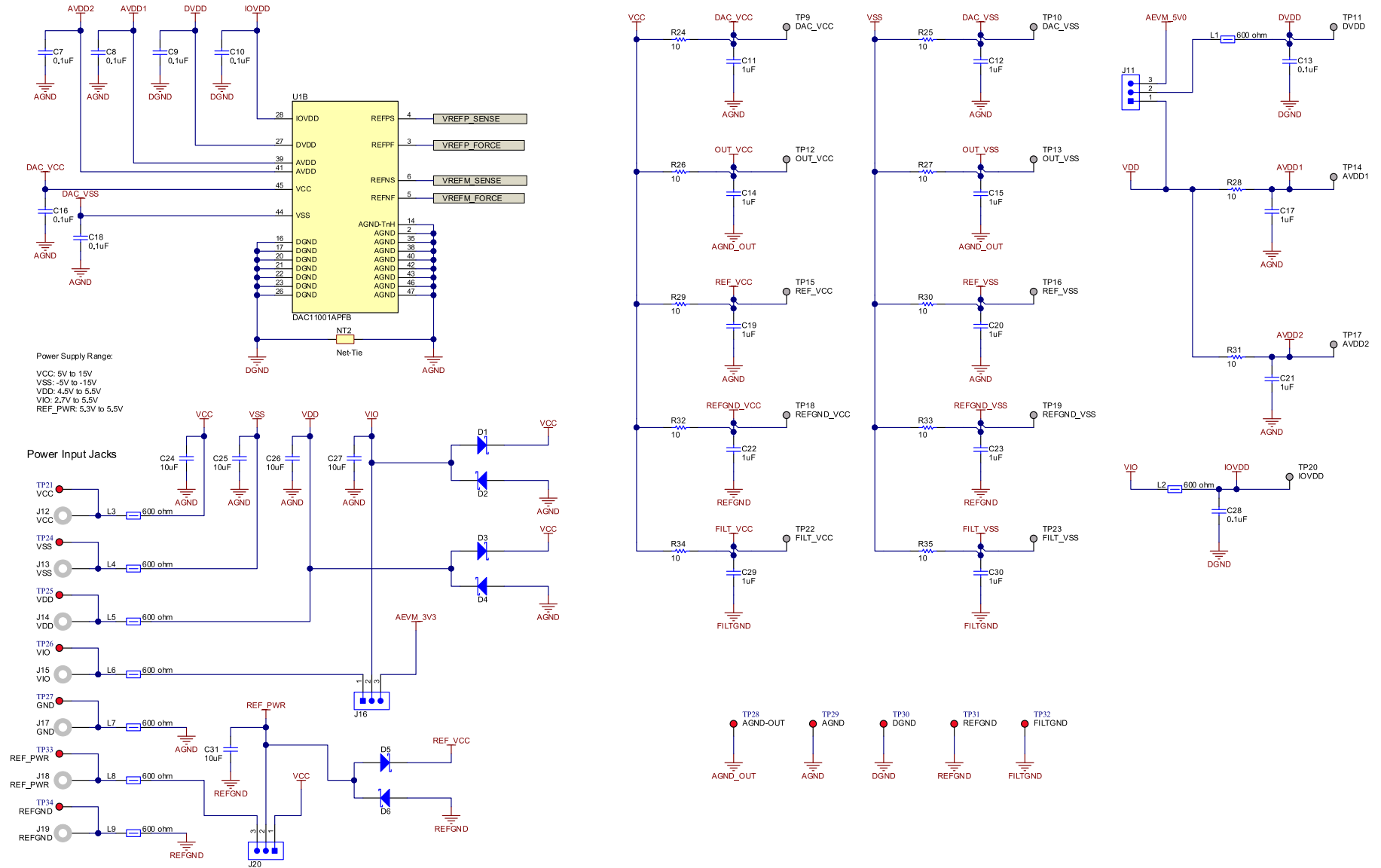

Figure 19. Schematic Page 4

## 4.2 PCB Layout

Figure 20 through Figure 25 show the layout details of the BP-DAC11001EVM board.

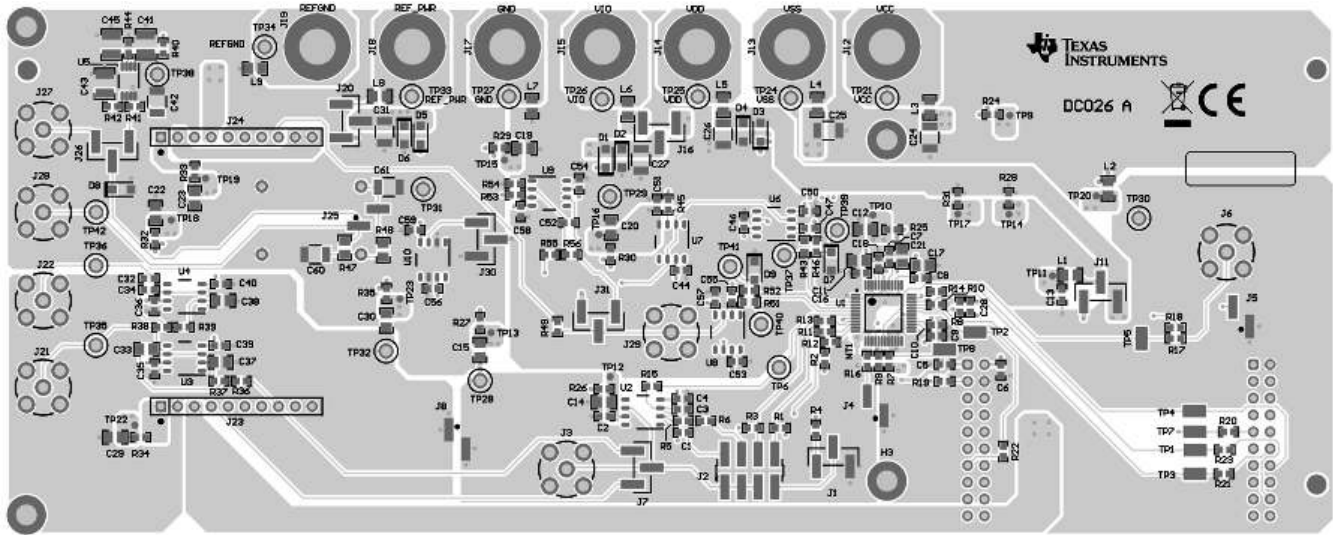

Figure 20. PCB Components: Top Overlay

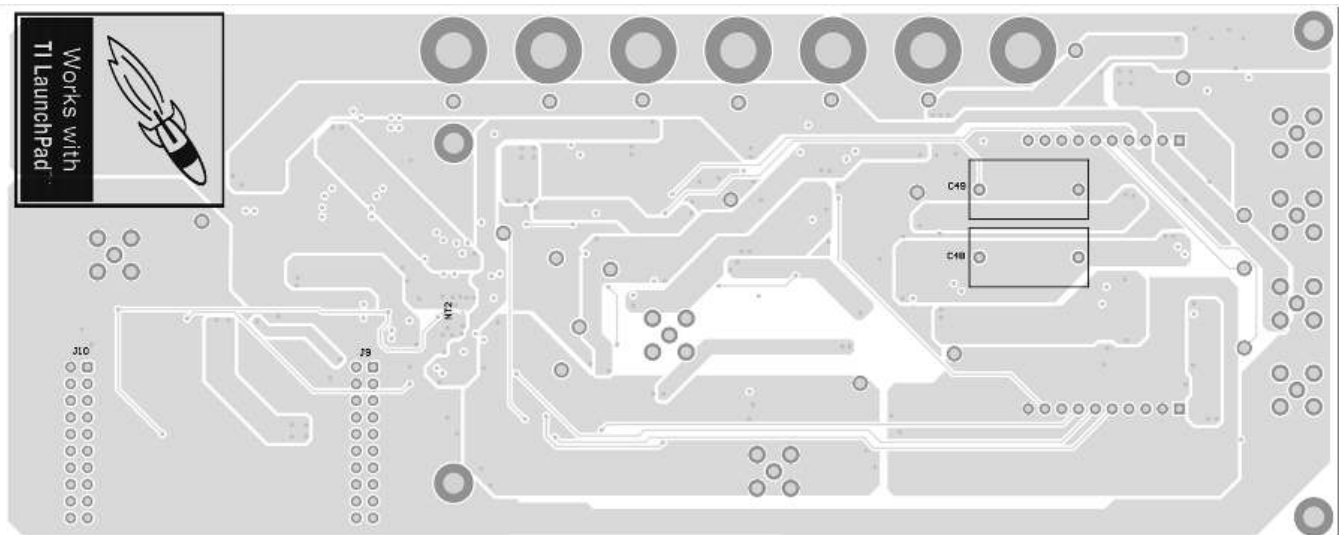

Figure 21. PCB Components: Bottom Overlay

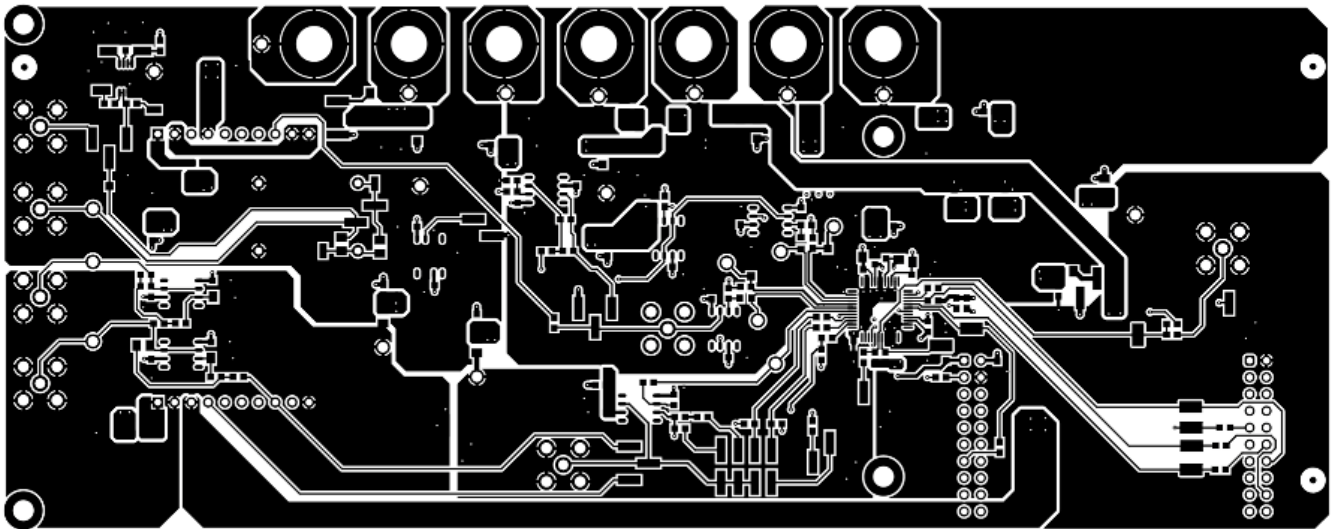

Figure 22. PCB Layout: Top Layer

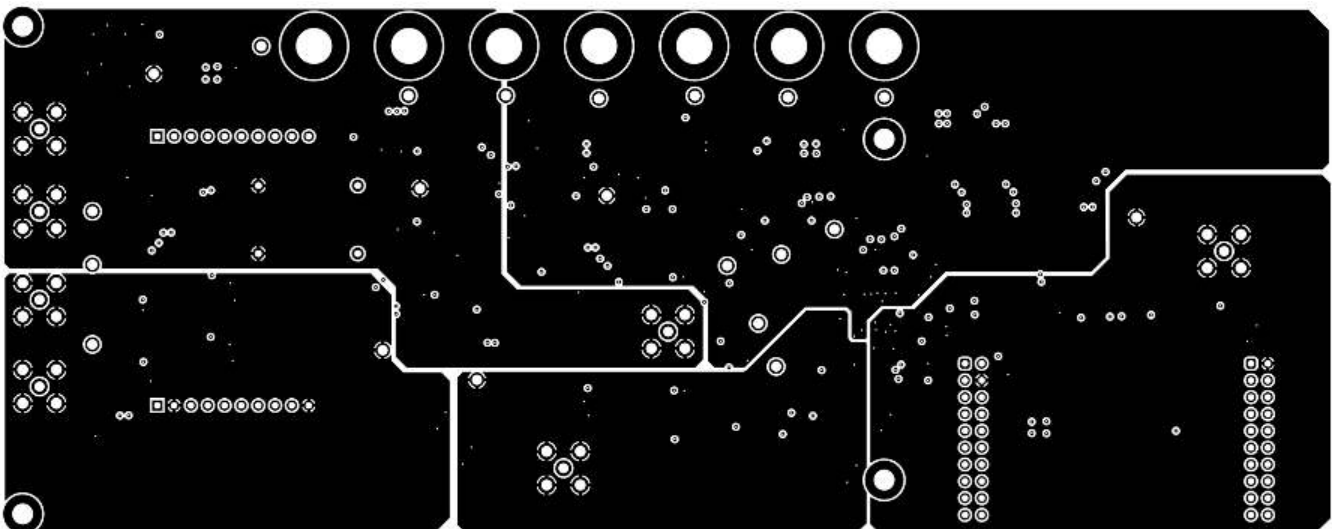

Figure 23. PCB Layout: Ground Plane

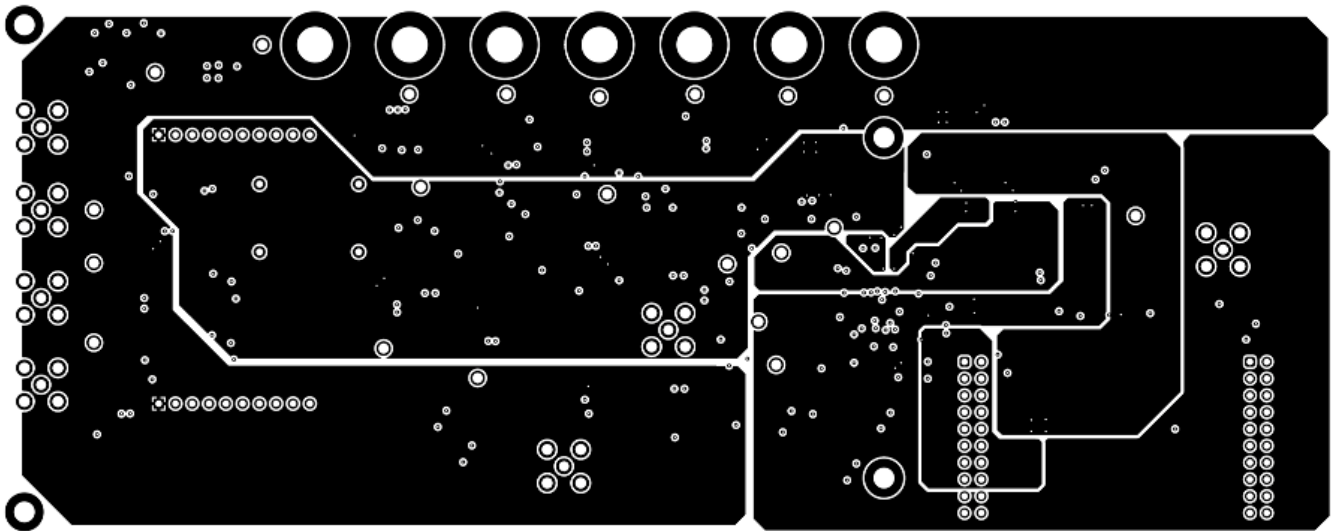

Figure 24. PCB Layout: Power Plane

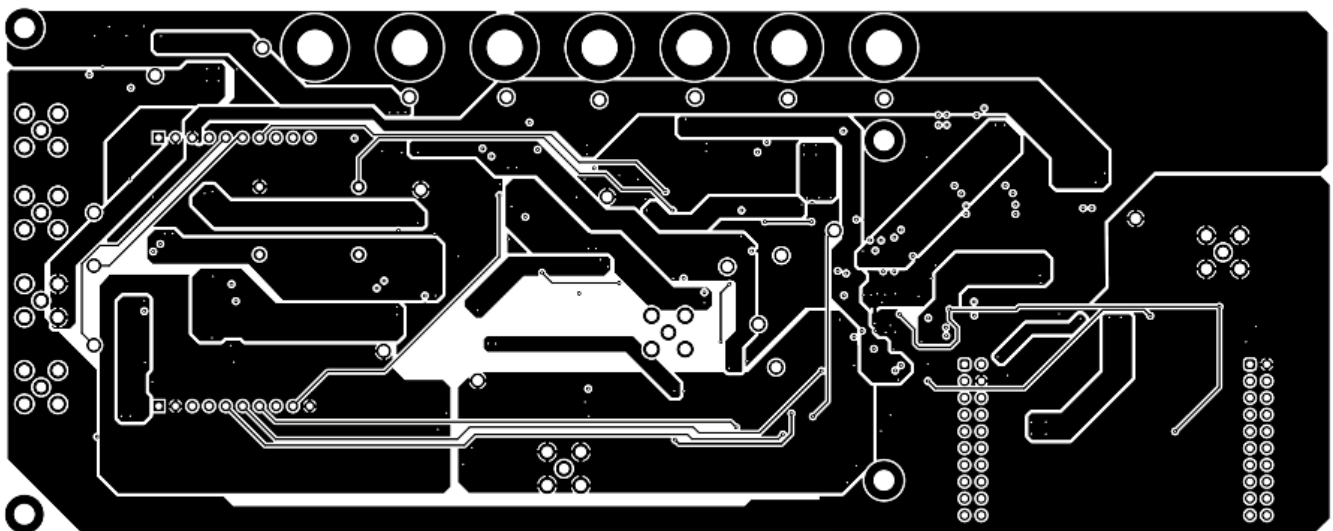

Figure 25. PCB Layout: Bottom Layer

### 4.3 BP-DAC11001EVM Bill of Materials

Table 6 lists the EVM bill of materials (BOM).

**Table 6. BP-DAC11001EVM Bill of Materials**

Designator	Quantity	Value	Description	Package Reference	Part Number	Manufacturer	Alternate Part Number	Alternate Manufacturer
!PCB1	1		Printed Circuit Board		DC026	Any		
C1, C47, C55	3	100pF	CAP, CERM, 100 pF, 50 V, +/- 5%, C0G/NPO, 0603	0603	885012006057	Würth Elektronik		
C2, C4, C7, C8, C9, C10, C13, C16, C18, C28, C35, C36, C39, C40, C44, C46, C50, C51, C53, C54, C56, C57, C58, C59	24	0.1uF	CAP, CERM, 0.1 uF, 50 V, +/- 10%, X7R, 0603	0603	GRM188R71H104KA93D	MuRata		
C5, C6	2	10uF	CAP, CERM, 10 uF, 10 V, +/- 20%, X5R, 0603	0603	C1608X5R1A106M080AC	TDK		
C11, C12, C14, C15, C17, C19, C20, C21, C22, C23, C29, C30	12	1uF	CAP, CERM, 1 uF, 50 V, +/- 10%, X7R, AEC-Q200 Grade 1, 0805	0805	CGA4J3X7R1H105K125AB	TDK		
C24, C25, C26, C27, C31, C42, C60, C61	8	10uF	CAP, CERM, 10 uF, 50 V, +/- 10%, X7S, AEC-Q200 Grade 1, 1210	1210	CGA6P3X7S1H106K250AB	TDK		
C32, C34	2	0.01uF	CAP, CERM, 0.01 uF, 50 V, +/- 5%, C0G/NPO, 0603	0603	GRM1885C1H103JA01D	MuRata		
C33, C37, C38	3	2700pF	CAP, CERM, 2700 pF, 25 V, +/- 5%, C0G/NPO, 0805	0805	08053A272JAT2A	AVX		
C41, C43, C45	3	1uF	CAP, Film, 1 uF, 16 V, +/- 20%, 1210 SMD	1210	ECPU1C105MA5	Panasonic		
D1, D2, D3, D4, D5, D6, D7, D8, D9	9	100V	Diode, Schottky, 100 V, 1 A, AEC-Q101, SOD-123W	SOD-123W	PMEG10010ELRX	Nexperia		
H1, H2, H3, H4	4		MACHINE SCREW PAN PHILLIPS 4-40	Machine Screw, 4-40, 1/4 inch	MSSS 440 0025 PH	B and F Fastener Supply		
J1, J7, J11, J16, J20, J26, J30, J31	8		Header, 100mil, 3x1, Gold, SMT	Samtec_TSM-103-01-X-SV	TSM-103-01-L-SV	Samtec		
J2	1		Header, 2.54mm, 4x2, Gold, SMT	Header, 2.54mm, 4x2, SMT	TSM-104-01-L-DV	Samtec		
J3, J6, J21, J22, J27, J28, J29	7		Connector, SMA, TH	SMA	142-0701-231	Cinch Connectivity		
J4, J5, J8, J25	4		Header, 100mil, 2x1, Gold with Tin Tail, SMT	2x1 Header	TSM-102-01-L-SV	Samtec		
J9, J10	2		Receptacle, 2.54mm, 10x2, Tin, TH	Receptacle, 2.54mm, 10x2, TH	ESQ-110-14-T-D	Samtec		
J12, J13, J14, J15, J17, J18, J19	7		Standard Banana Jack, Uninsulated, 5.5mm	Keystone_575-4	575-4	Keystone		
J23, J24	2		Receptacle, 100mil, 10x1, Tin, TH	Receptacle, 10x1, 100mil, Tin	PPTC101LFBN-RC	Sullins Connector Solutions		

**Table 6. BP-DAC11001EVM Bill of Materials (continued)**

Designator	Quantity	Value	Description	Package Reference	Part Number	Manufacturer	Alternate Part Number	Alternate Manufacturer
L1, L2, L3, L4, L5, L6, L7, L8, L9	9	600 ohm	Ferrite Bead, 600 ohm at 100 MHz, 2.1 A, 0805	0805	74279220601	Würth Elektronik		
LBL1	1		Thermal Transfer Printable Labels, 0.650" W x 0.200" H - 10,000 per roll	PCB Label 0.650 x 0.200 inch	THT-14-423-10	Brady		
R4, R5, R11, R12, R13, R15, R16, R46, R52, R54	10	0	RES, 0, 1%, 0.1 W, AEC-Q200 Grade 0, 0603	0603	RMCF0603ZT0R00	Stackpole Electronics Inc		
R6	1	2.4k	RES, 2.4 k, 0.05%, 0.1 W, AEC-Q200 Grade 0, 0603	0603	RG1608N-242-W-T1	Susumu Co Ltd		
R7, R8, R9, R10	4	10.0k	RES, 10.0 k, 1%, 0.1 W, 0603	0603	RC0603FR-0710KL	Yageo		
R14, R17, R18, R19, R20, R21, R22, R23	8	33	RES, 33, 5%, 0.1 W, AEC-Q200 Grade 0, 0603	0603	CRCW060333R0JNEA	Vishay-Dale		
R24, R25, R26, R27, R28, R29, R30, R31, R32, R33, R34, R35, R40	13	10	RES, 10, 5%, 0.1 W, AEC-Q200 Grade 0, 0603	0603	CRCW060310R0JNEA	Vishay-Dale		
R36	1	2.49k	RES, 2.49 k, 1%, 0.1 W, AEC-Q200 Grade 0, 0603	0603	CRCW06032K49FKEA	Vishay-Dale		
R37	1	3.40k	RES, 3.40 k, 1%, 0.1 W, AEC-Q200 Grade 0, 0603	0603	CRCW06033K40FKEA	Vishay-Dale		
R38	1	866	RES, 866, 1%, 0.1 W, AEC-Q200 Grade 0, 0603	0603	CRCW0603866RFKEA	Vishay-Dale		
R39	1	1.58k	RES, 1.58 k, 1%, 0.1 W, AEC-Q200 Grade 0, 0603	0603	CRCW06031K58FKEA	Vishay-Dale		
R41	1	0.51	RES, 0.51, 1%, 0.1 W, AEC-Q200 Grade 1, 0603	0603	ERJ-3RQFR51V	Panasonic		
R42	1	1.00	RES, 1.00, 1%, 0.1 W, 0603	0603	RC0603FR-071RL	Yageo		
R43, R51	2	22	RES, 22.0, 0.1%, 0.063 W, 0603	0603	CPF0603B22RE1	TE Connectivity		
R44	1	51k	RES, 51 k, 5%, 0.1 W, AEC-Q200 Grade 0, 0603	0603	CRCW060351K0JNEA	Vishay-Dale		
R47, R48	2	4.99k	RES, 4.99 k, 0.1%, 0.125 W, 0805	0805	RT0805BRD074K99L	Yageo America		
R55, R56	2	1.00k	RES, 1.00 k, 0.01%, 0.15 W, 0603	0603	PLTU0603U1001LST5	Vishay-Dale		
SH-JP1, SH-JP2, SH-JP3, SH-JP4, SH-JP5, SH-JP6, SH-JP7, SH-JP8, SH-JP9, SH-JP10	10	1x2	Shunt, 100mil, Gold plated, Black	Shunt	SNT-100-BK-G	Samtec	969102-0000-DA	3M
TP6, TP21, TP24, TP25, TP26, TP27, TP28, TP29, TP30, TP31, TP32, TP33, TP34, TP35, TP36, TP37, TP38, TP39, TP40, TP41, TP42	21		Test Point, Compact, Red, TH	Red Compact Testpoint	5005	Keystone		



**Table 6. BP-DAC11001EVM Bill of Materials (continued)**

Designator	Quantity	Value	Description	Package Reference	Part Number	Manufacturer	Alternate Part Number	Alternate Manufacturer
U1	1		20-/18-/16-Bit, Low Noise, Ultra Low Harmonic Distortion, Fast Settling, High-Voltage Output Digital-to-Analog Converters (DACs), PFB0048A (TQFP-48)	PFB0048A	DAC11001APFB	Texas Instruments		
U2, U6, U7, U8, U9, U10	6		36-Volt, High-speed (45 MHz GBW and 150V/ $\mu$ s SR), low-noise (4nV/ $\sqrt$ Hz) RRO JFET operational amplifier, D0008A (SOIC-8)	D0008A	OPA828IDR	Texas Instruments		
U3, U4	0		1.1 nV/ $\sqrt$ Hz Noise, Low Power, Precision Operational Amplifier, 4.5 to 36 V, -40 to 85 degC, 8-pin SOIC (D8), Green (RoHS & no Sb/Br)	D0008A	OPA1611AID	Texas Instruments		
U5	1		High-Precision Voltage Reference with Integrated High-Bandwidth Buffer, DGK0008A (VSSOP-8)	DGK0008A	REF6250IDGKR	Texas Instruments	REF6250IDGKT	Texas Instruments
C3, C52	0	100pF	CAP, CERM, 100 pF, 50 V, +/- 5%, C0G/NP0, 0603	0603	885012006057	Würth Elektronik		
C48, C49	0	10uF	CAP, Film, 10 uF, 63 V, +/- 10%, TH	18x17.5x9mm	B32522C106K	TDK		
FID1, FID2, FID3	0		Fiducial mark. There is nothing to buy or mount.	N/A	N/A	N/A		
R1, R2, R3, R45, R49, R53	0	0	RES, 0, 1%, 0.1 W, AEC-Q200 Grade 0, 0603	0603	RMCF0603ZT0R00	Stackpole Electronics Inc		

## IMPORTANT NOTICE AND DISCLAIMER

TI PROVIDES TECHNICAL AND RELIABILITY DATA (INCLUDING DATA SHEETS), DESIGN RESOURCES (INCLUDING REFERENCE DESIGNS), APPLICATION OR OTHER DESIGN ADVICE, WEB TOOLS, SAFETY INFORMATION, AND OTHER RESOURCES "AS IS" AND WITH ALL FAULTS, AND DISCLAIMS ALL WARRANTIES, EXPRESS AND IMPLIED, INCLUDING WITHOUT LIMITATION ANY IMPLIED WARRANTIES OF MERCHANTABILITY, FITNESS FOR A PARTICULAR PURPOSE OR NON-INFRINGEMENT OF THIRD PARTY INTELLECTUAL PROPERTY RIGHTS.

These resources are intended for skilled developers designing with TI products. You are solely responsible for (1) selecting the appropriate TI products for your application, (2) designing, validating and testing your application, and (3) ensuring your application meets applicable standards, and any other safety, security, regulatory or other requirements.

These resources are subject to change without notice. TI grants you permission to use these resources only for development of an application that uses the TI products described in the resource. Other reproduction and display of these resources is prohibited. No license is granted to any other TI intellectual property right or to any third party intellectual property right. TI disclaims responsibility for, and you will fully indemnify TI and its representatives against, any claims, damages, costs, losses, and liabilities arising out of your use of these resources.

TI's products are provided subject to [TI's Terms of Sale](#) or other applicable terms available either on [ti.com](http://ti.com) or provided in conjunction with such TI products. TI's provision of these resources does not expand or otherwise alter TI's applicable warranties or warranty disclaimers for TI products.

TI objects to and rejects any additional or different terms you may have proposed.

Mailing Address: Texas Instruments, Post Office Box 655303, Dallas, Texas 75265  
Copyright © 2022, Texas Instruments Incorporated