

PART NUMBER  
10090081-101LF

# 48 Pair Cable Connector (2 Outlets)

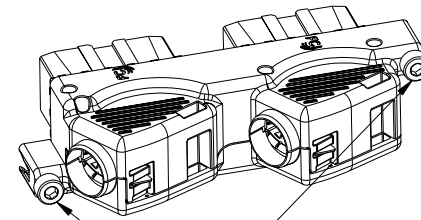
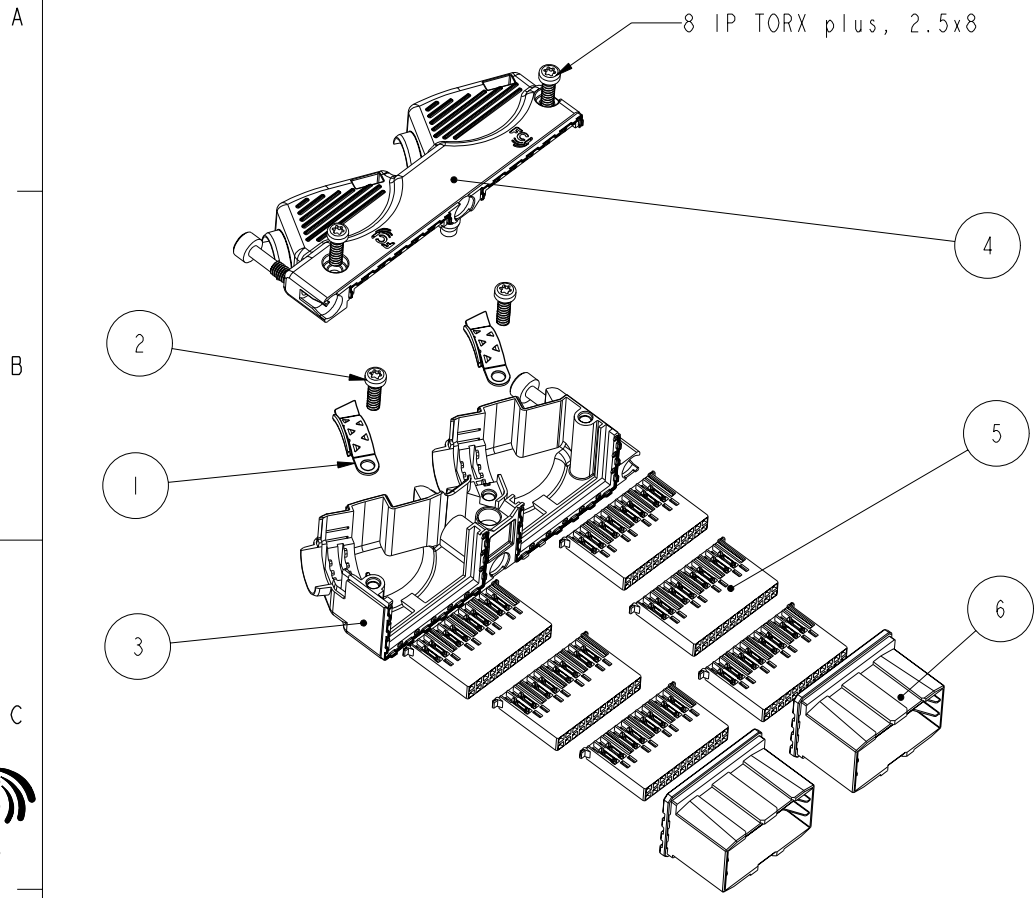

Hexagon M3.0x4  
(Pre-assembled in cover-parts)

6	SHROUD	2
5	TERMINAL BLOCK ASSEMBLY	6
4	SUB ASSEMBLY TOP-COVER	1
3	SUB ASSEMBLY BOTTOM-COVER	1
2	CONNECTOR SELF TAPPING SCREW	4
1	CLAMP	2
INDEX NO.	TITLE I	QTY

Copyright FCI.

rev	ecn no	dr	date
I	H08-0070	MSI	20080701
A	N10-0383	ANDY	2011-01-24
-	-	-	-
-	-	-	-
-	-	-	-
-	-	-	-

www.fciconnect.com		surface - ISO 1302	tolerance std ISO 406 / ISO 1101	projection MM	
TOLERANCES UNLESS OTHERWISE SPECIFIED				size A3	Scale 1:3
Dr	M.SIVAKUMAR	2008-07-01	ANGULAR	0.x ±0.35	
Eng	J.DE BRUIJN	2008-07-01	LINEAR	0.xx ±0.25	
Chr	J.DE BRUIJN	2008-07-01	0° ±5°	0.xxx ±0.15	ECN N10-0383
Appr	J.DE BRUIJN	2008-07-01	Product family	Metral	Spec ref -
FCI		title ASSEMBLY KIT		dwg no	10090081
		METRAL HDXS 48 PAIR 20 CABLE CONN.		Rev.	A
catalog no		CUSTOMER		sheet 1 of 4	

PART NUMBER  
10090081-101LF

# TOP CABLING

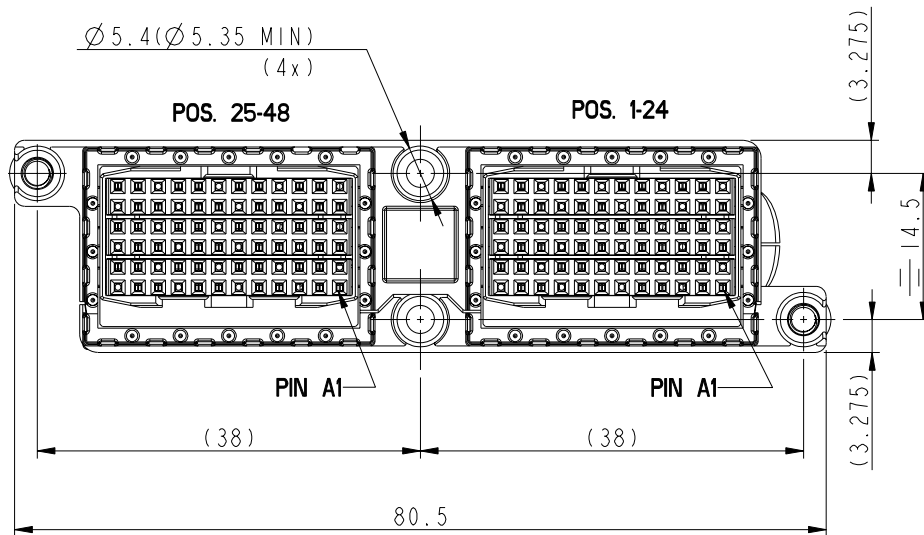
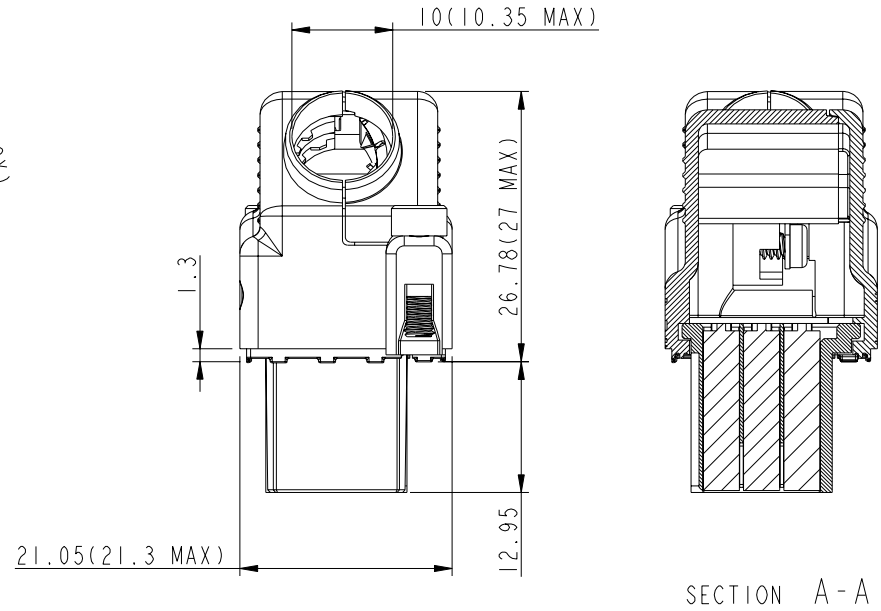
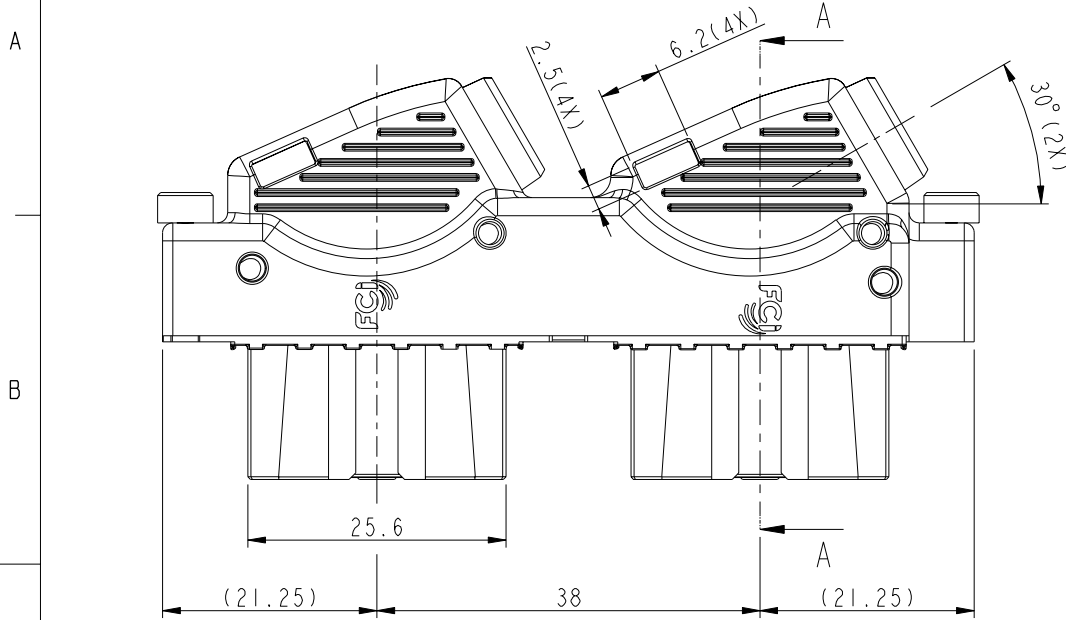

Copyright FCi  
FCi

www.fciconnect.com		surface ISO 1302	tolerance std ISO 406 / ISO 1101	projection MM	
		TOLERANCES UNLESS OTHERWISE SPECIFIED			
Dr	M.SIVAKUMAR	2008-07-01	ANGULAR	0.X	±0.35
Eng	J.DE BRUIJN	2008-07-01	LINEAR	0.XX	±0.25
Chr	J.DE BRUIJN	2008-07-01	0° ±5°	0.XXX	±0.15
Appr	J.DE BRUIJN	2008-07-01	Product family	Metral	Spec ref
Title		ASSEMBLY KIT		dwg no	10090081
Title		METRAL HDXS 48 PAIR 20 CABLE CONN.		Rev.	A
catalog no		-		CUSTOMER	sheet 2 of 4

REV F - 2006-04-17

PART NUMBER  
10090081-101LF

# BOTTOM CABLING

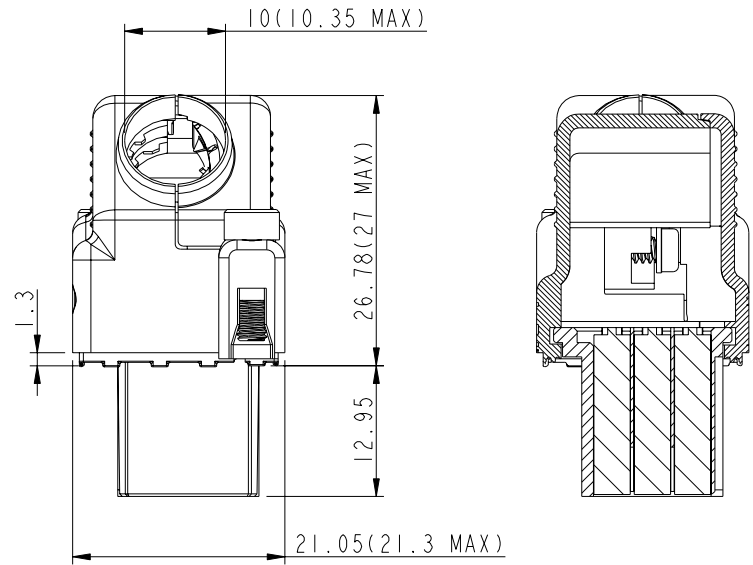
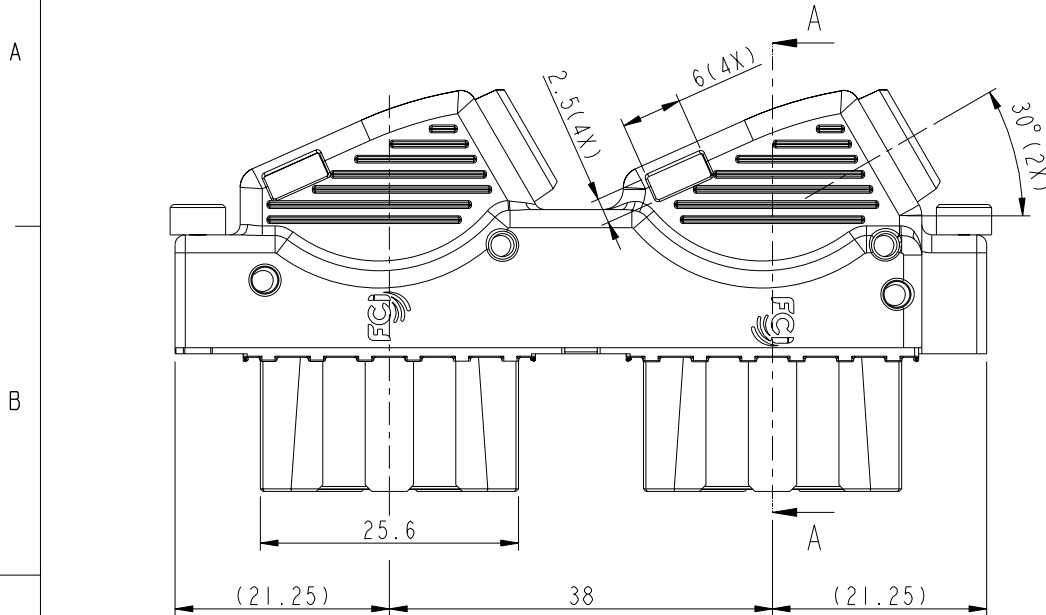

SECTION A-A

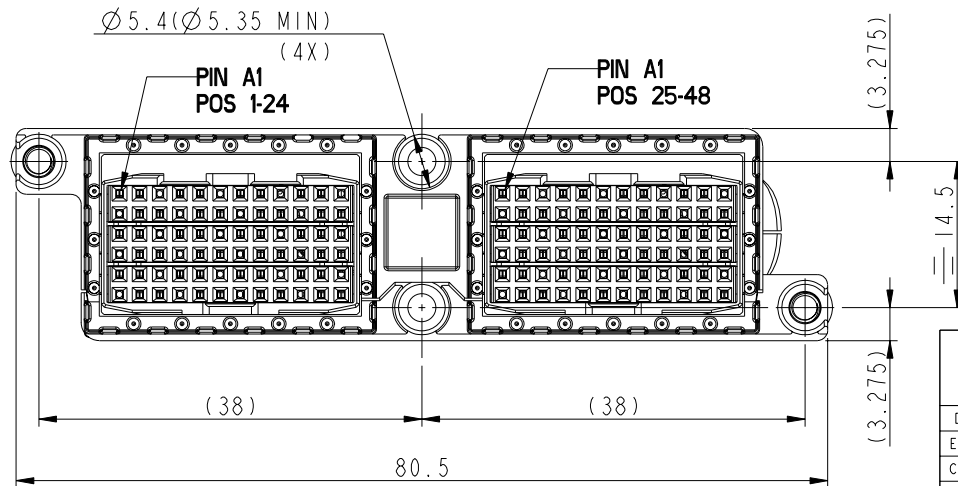

Copyright FCi.

www.fciconnect.com		surface ISO 1302	tolerance std ISO 406 / ISO 1101	projection MM	
		TOLERANCES UNLESS OTHERWISE SPECIFIED			
Dr	M.SIVAKUMAR	2008-07-01	ANGULAR	0.X	±0.35
Eng	J.DE BRUIJN	2008-07-01	LINEAR	0.XX	±0.25
Chr	J.DE BRUIJN	2008-07-01	0° ±5°	0.XXX	±0.15
Appr	J.DE BRUIJN	2008-07-01	Product family	Metral	Spec ref
Title		ASSEMBLY KIT		dwg no	10090081
Title		METRAL HDXS 48 PAIR 20 CABLE CONN.		Rev.	A
catalog no		-		CUSTOMER	sheet 3 of 4

REV F - 2006-04-17

PART NUMBER  
10090081-101LF

# Cable diameter and cable clamp position

Cable Clamp at pos.A  
for cable diameters  
Ø 7mm-Ø 8mm

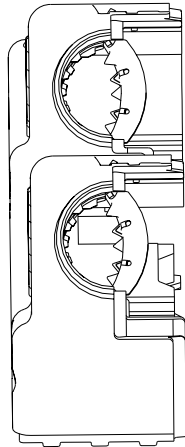

Cable Clamp at pos.A  
for cable diameters  
Ø 9mm-Ø 10mm

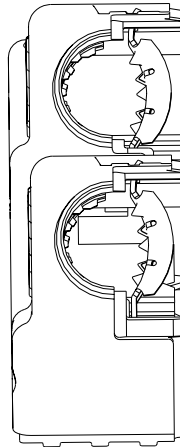

## NOTES:

- 1.Product Specification: GS-12-485.
- 2.Packaging Specification: GS-14-1265.
- 3.Application Specification: GS-20-091.
- 4.Performance level: Telcorida CO.
- 5.Flammability classification: UL94 V-0.
- 6.RoHS Compliant.
- 7.Wire Size: AWG 26.

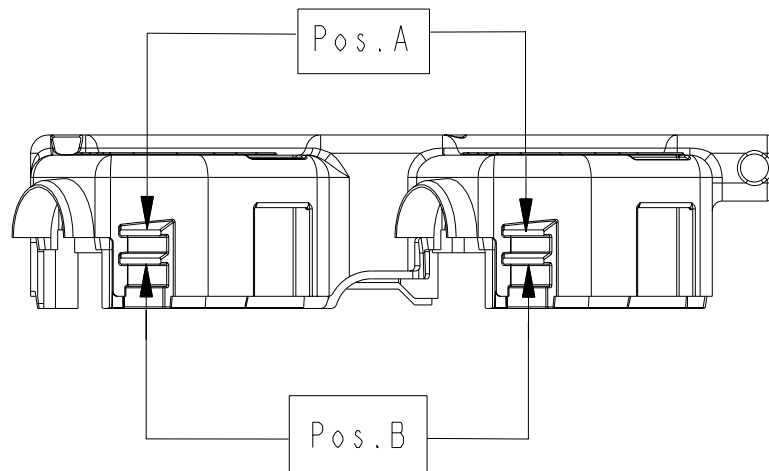

Copyright FCI.

www.fciconnect.com			surface ISO 1302	tolerance std ISO 406 / ISO 1101	projection MM	TOLERANCES UNLESS OTHERWISE SPECIFIED	
Dr	M.SIVAKUMAR	2008-07-01	ANGULAR	0.X	±0.35	size	Scale
Eng	J.DE BRUIJN	2008-07-01	LINEAR	0.XX	±0.25	A3	1:3
Chr	J.DE BRUIJN	2008-07-01	0° ±5°	0.XXX	±0.15	ECN	N10-0383
Appr	J.DE BRUIJN	2008-07-01	Product family	Metral	Spec ref	-	
			title ASSEMBLY KIT		dwg no	10090081	Rev.
			METRAL HDXS 48 PAIR 20 CABLE CONN.				A
			catalog no	-	CUSTOMER	sheet 4 of 4	

REV F - 2006-04-17