

PART NUMBER SYSTEM
ME300560231104X

PLATING SPEC
 1 0.76UM AU MIN OVER 1.27UM MIN NI
 2 0.38UM AU MIN OVER 1.27UM MIN NI
 5 1.27UM AU MIN OVER 1.27UM MIN NI

spec ref	dr	Jun. Fan	Apr. 26, 2021	<h2 style="margin: 0;">Amphenol</h2>	MM	scale	2:1	size	A3
tolerance std	eng	Jun. Fan	Apr. 26, 2021		ecn no	ECN2474			
TOLERANCES UNLESS OTHERWISE SPECIFIED linear 0.X ± 0.25 0.XX ± 0.20 0.XXX ± 0.15 angular 0° ± 2°	rvmr				amphenol-icc.com	rel level	RELEASE		
	appr				product family	MINI COOL EDGE	sheet 1 of 7		
surface	projection	MINI COOL EDGE CONNECTOR 0.6MM PITCH_IX4_ORTH, 85 Ohm, Gen5		title MINI COOL EDGE CONNECTOR	cat. no. C ME300560231104X	rev 6			

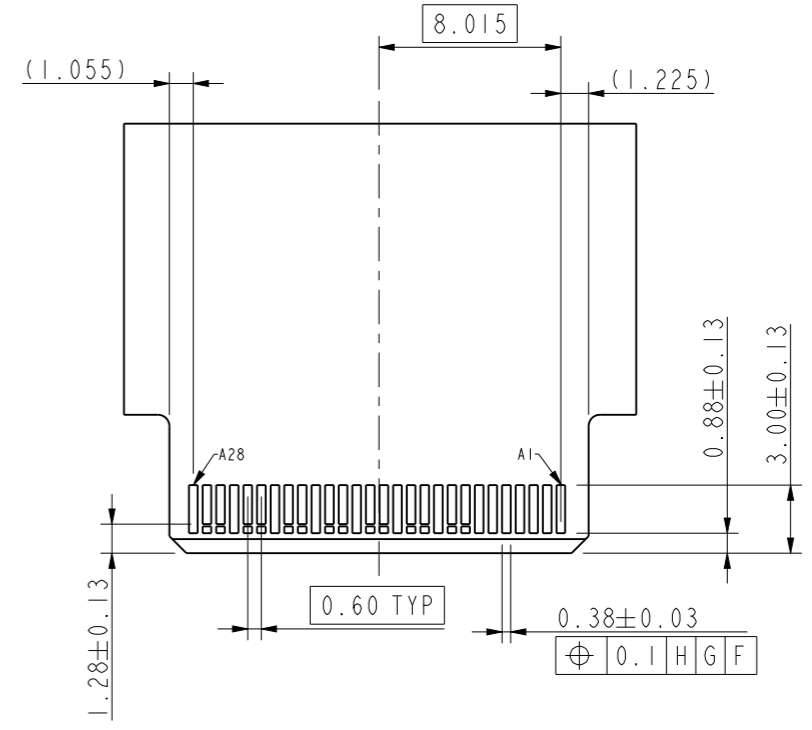
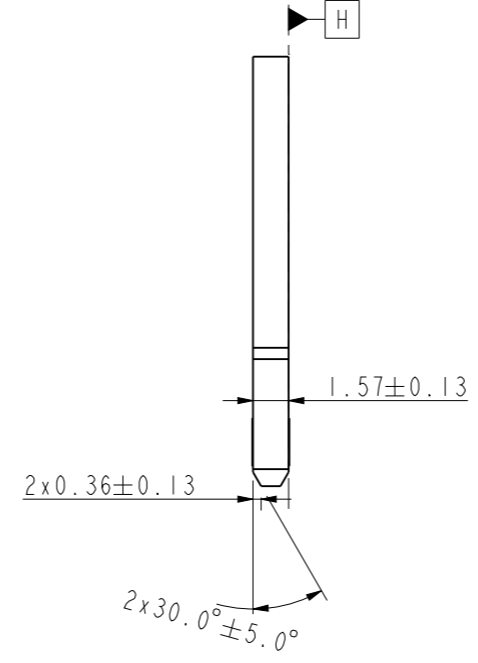
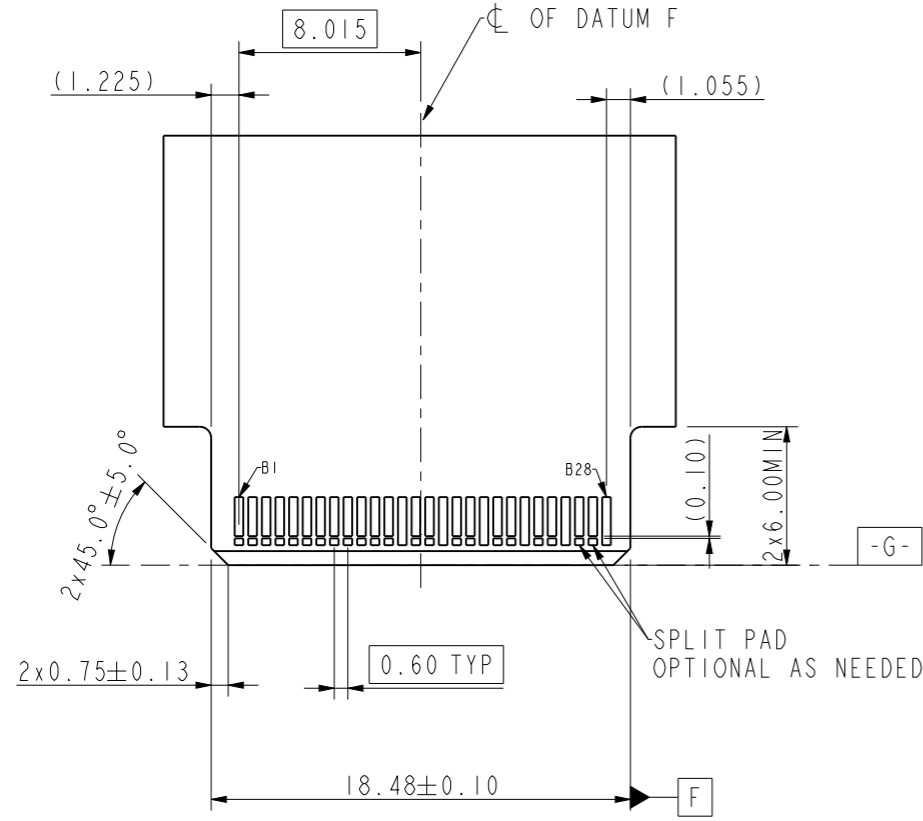

RECOMMENDED LAYOUT FOR MATING CARD, THICKNESS=1.57MM
 GENERAL TOLERANCE ±0.05
 FOLLOW EDSFF SPEC

spec ref		dr Jun. Fan Apr. 26, 2021		Amphenol	MM	scale	size
tolerance std		eng Jun. Fan Apr. 26, 2021				3:1	A3
TOLERANCES UNLESS OTHERWISE SPECIFIED		r vwr				ECN2474	
		appr		RELEASE			
surface	linear	0.X	± 0.25	projection	MINI COOL EDGE CONNECTOR	cat. no.	rev
		0.XX	± 0.20			C ME300560231104X	6
		0.XXX	± 0.15				
	angular	0°	± 2°		product family	MINI COOL EDGE	sheet 2 of 7

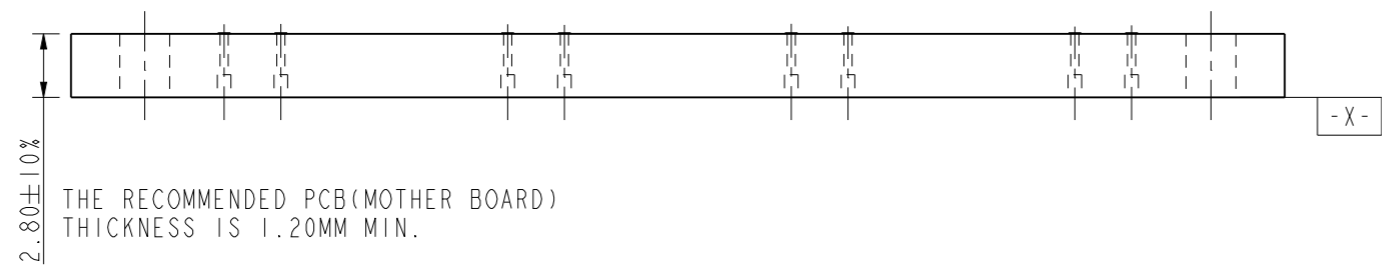
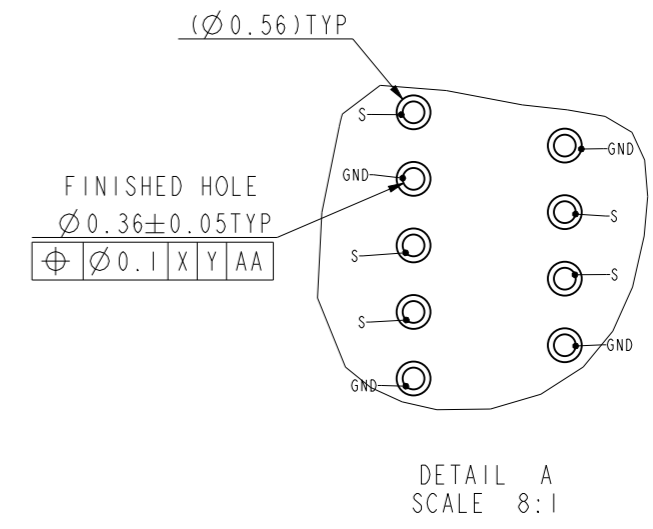
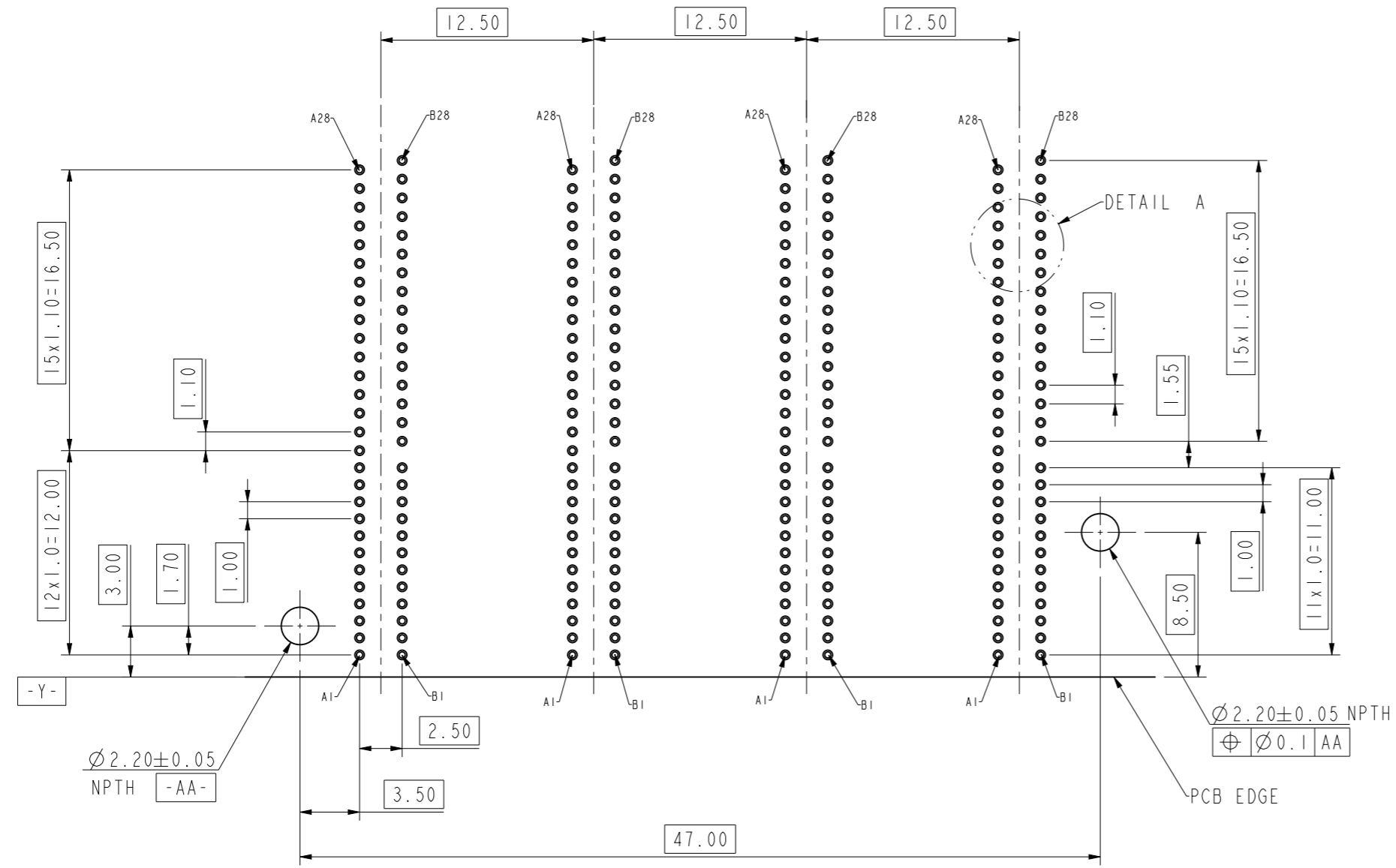

RECOMMENDED PCB LAYOUT FOR DIFFERENTIAL APPLICATIONS
 COMPONENT SIDE
 GENERAL TOLERANCE ±0.05

spec ref	dr	Jun. Fan	Apr. 26, 2021	Amphenol	MM	scale	size
tolerance std	eng	Jun. Fan	Apr. 26, 2021		←	3:1	A3
TOLERANCES UNLESS OTHERWISE SPECIFIED	rvwr				ecn no	ECN2474	
	appr				rel level	RELEASE	
surface	linear	0.X	± 0.25	projection	title	MINI COOL EDGE CONNECTOR	rev
		0.XX	± 0.20			0.6MM PITCH_1X4_ORTH, 85 Ohm, Gen5	6
		0.XXX	± 0.15				
	angular	0°	± 2°		product family	MINI COOL EDGE	sheet 3 of 7

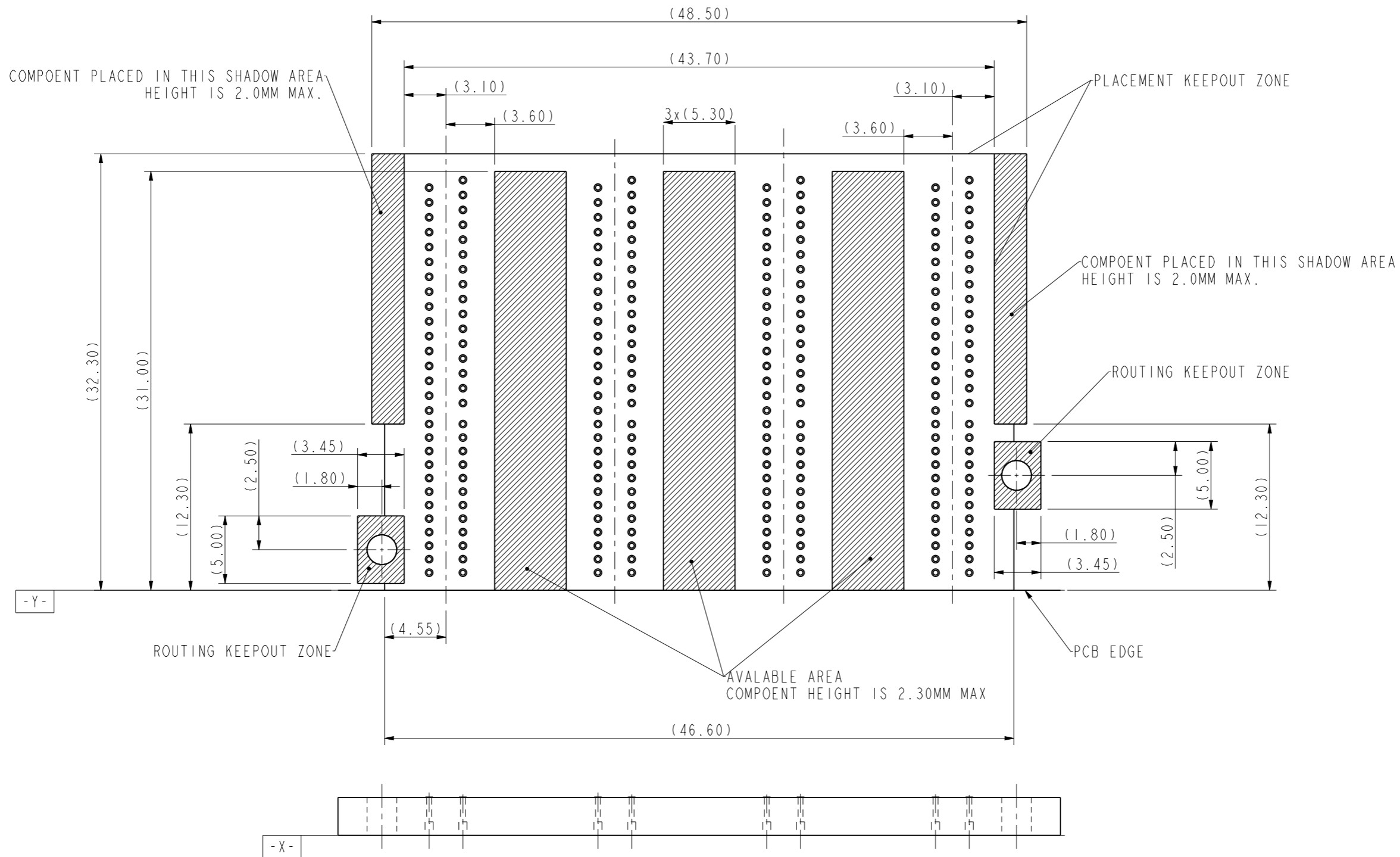

KEEPOUT ZONE
FOR INSTALLATION PROCEDURE
(APMPHENOL INSTALLATION TOOLING:CE100541X4PF)

spec ref		dr	Jun. Fan	Apr. 26, 2021		MM	scale	size
tolerance std		eng	Jun. Fan	Apr. 26, 2021		←	3:1	A3
TOLERANCES UNLESS OTHERWISE SPECIFIED		r vwr				ecn no ECN2474		
		appr				rel level RELEASE		
surface	linear	0.X	± 0.25	projection		amphenol-icc.com		rev 6
		0.XX	± 0.20			MINI COOL EDGE CONNECTOR		
		0.XXX	± 0.15			0.6MM PITCH_1X4_ORTH, 85 Ohm, Gen5		
	angular	0°	± 2°	product family	MINI COOL EDGE	cat. no.	C ME300560231104X	sheet 4 of 7

COMPONENT PLACED IN THIS SHADOW AREA
HEIGH IS 2.0MM MAX.

PLACEMENT KEEPOUT ZONE

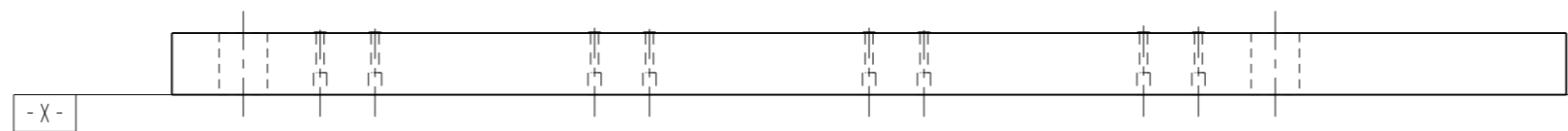
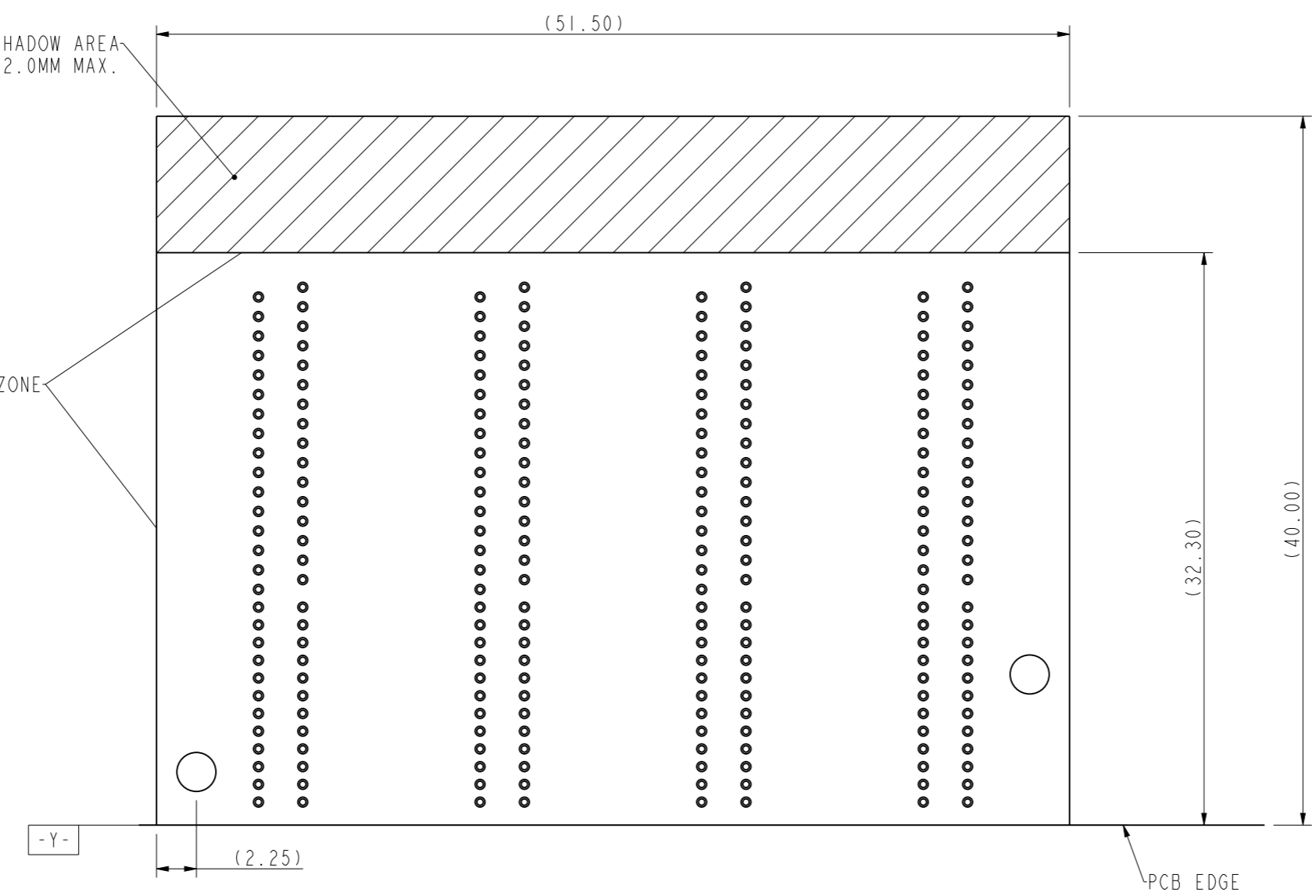

KEEPOUT ZONE
FOR REMOVAL PROCEDURE
(AMPHENOL REMOVAL TOOLING :ME20056RM002)

spec ref		dr	Jun. Fan	Apr. 26, 2021	Amphenol	MM	scale	size
tolerance std		eng	Jun. Fan	Apr. 26, 2021		←	3:1	A3
TOLERANCES UNLESS OTHERWISE SPECIFIED		r vwr				ecn no	ECN2474	
		appr			amphenol-icc.com		rel level	RELEASE
surface	linear	0.X	± 0.25	projection	MINI COOL EDGE CONNECTOR	C ME300560231104X	cat. no.	rev
		0.XX	± 0.20					
	0.XXX	± 0.15						
	angular	0°	± 2°	0.6MM PITCH_1X4_ORTH, 85 Ohm, Gen5	product family	MINI COOL EDGE	sheet 5 of 7	

Pin	Contact Sequence	Signal	Signal	Contact Sequence	Pin
B1	2nd mate	12V	GND	1st mate	A1
B2	2nd mate	12V	GND	1st mate	A2
B3	2nd mate	12V	GND	1st mate	A3
B4	2nd mate	12V	GND	1st mate	A4
B5	2nd mate	12V	GND	1st mate	A5
B6	2nd mate	12V	GND	1st mate	A6
B7	2nd mate	MFC	SMBCLK	2nd mate	A7
B8	2nd mate	RFU	SMBDAT	2nd mate	A8
B9	2nd mate	DUALPORTEN#	SMBRST#	2nd mate	A9
B10	2nd mate	PERST0#	LED#/ACTIVITY	2nd mate	A10
B11	2nd mate	3.3VAux	PERST1#/CLKREQ#	2nd mate	A11
B12	2nd mate	PWRDIS	PRSNT0#	2nd mate	A12
B13	1st mate	GND	GND	1st mate	A13
B14	2nd mate	RFFCLKn0	RFFCLKn1	2nd mate	A14
B15	2nd mate	RFFCLKp0	RFFCLKp1	2nd mate	A15
B16	1st mate	GND	GND	1st mate	A16
B17	2nd mate	PETn0	PERn0	2nd mate	A17
B18	2nd mate	PETp0	PERp0	2nd mate	A18
B19	1st mate	GND	GND	1st mate	A19
B20	2nd mate	PETn1	PERn1	2nd mate	A20
B21	2nd mate	PETp1	PERp1	2nd mate	A21
B22	1st mate	GND	GND	1st mate	A22
B23	2nd mate	PETn2	PERn2	2nd mate	A23
B24	2nd mate	PETp2	PERp2	2nd mate	A24
B25	1st mate	GND	GND	1st mate	A25
B26	2nd mate	PETn3	PERn3	2nd mate	A26
B27	2nd mate	PETp3	PERp3	2nd mate	A27
B28	1st mate	GND	GND	1st mate	A28

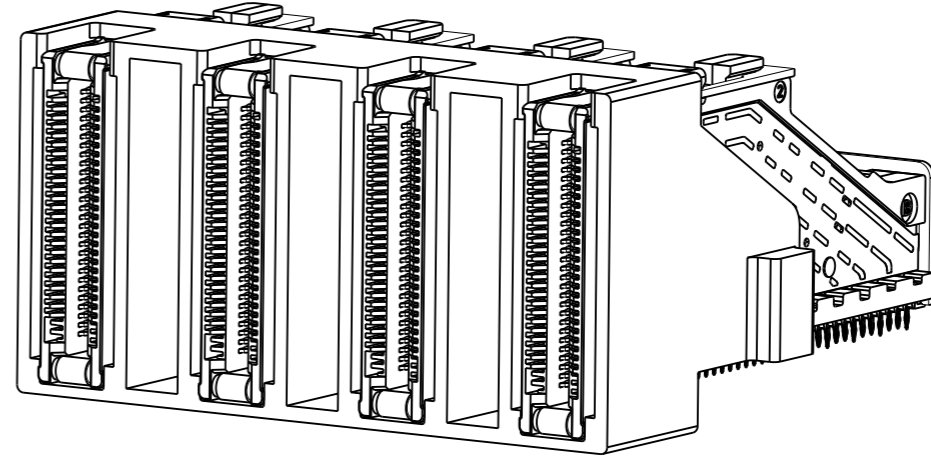

NOTES:

- CONNECTOR MATERIALS:
 HOUSING: HIGH TEMP THERMOPLASTIC, NATURAL, UL94V-0
 IMLA PLASTIC: HIGH TEMP THERMOPLASTIC, BLACK, UL94V-0
 SHIELD: CONDUCTIVE HIGH TEMP THERMOPLASTIC BLACK UL94-V0
 CONTACT: COPPER ALLOY
 METAL KEY: COPPER ALLOY
 METAL FRAMEWORK: ZN ALLOY
 METAL STIFFENER: STAINLESS STEEL
- CONTACT PLATING:
 SEPARABLE INTERFACE: SEE PLATING SPEC OVER 1.27UM MIN NICKEL UNDER PLATED.
 PRESS-FIT TAILS: MATTE TIN OVER 1.27UM MIN NICKEL UNDER PLATED.
- PRODUCT MARKING, (PARTNUMBER & DATE CODE)
- MATERIAL SHOULD BE FULFILLED AMPHENOL SPEC # SSN002 AND MEET HALOGEN FREE
- PCB DRILL HOLE AND PLATING SPEC SEE TABLE 1

CONNECTOR PINOUT DEFINITIONS
 (EDSFF X4 DEVICE EDGE PINOUT)
 CONNECTOR PIN A1~A6 AND PIN B1~B6 ARE LINKED TOGETHER RESPECTIVELY

spec ref		dr	Jun. Fan	Apr. 26, 2021		MM	scale	size	
tolerance std		eng	Jun. Fan	Apr. 26, 2021		←	3:1	A3	
TOLERANCES UNLESS OTHERWISE SPECIFIED		rivr				ecn no	ECN2474		
		appr			amphenol-icc.com		rel level	RELEASE	
surface	linear	0.X	± 0.25	projection		MINI COOL EDGE CONNECTOR		dng no C ME300560231104X	rev
		0.XX	± 0.20			0.6MM PITCH_1X4_ORTH, 85 Ohm, Gen5		cat. no.	6
		0.XXX	± 0.15			product family		MINI COOL EDGE	sheet 6 of 7
	angular	0°	± 2°						

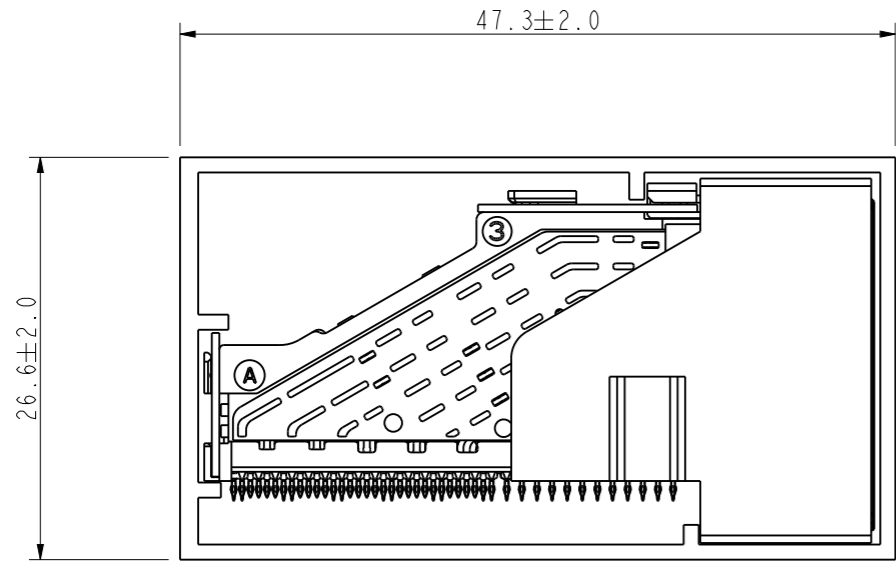

PACKING TUBE
LEFT VIEW WITHOUT STOPPER

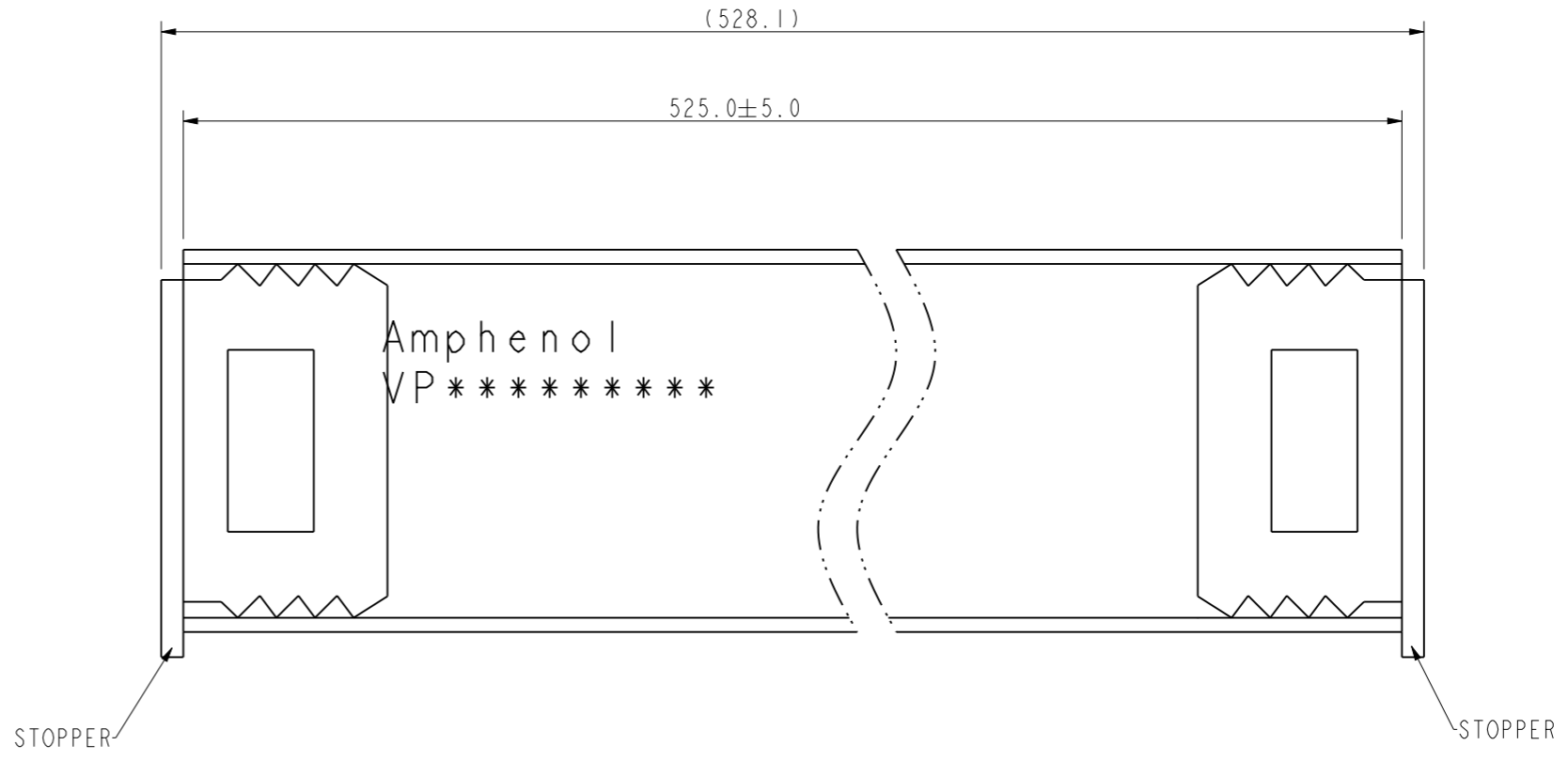

PACKING TUBE
FRONT VIEW WITH STOPPER

NOTE:
 1. TUBE MATERIAL: CLEAN PVC, ANTISTATIC, BLUE;
 2. MATERIAL IS COMPLIANT TO ROHS AND HF;
 3. PACKING QTY:
 10 PCS/TUBE
 100 PCS/CARTON

spec ref				dr	Jun. Fan	Apr. 26, 2021	Amphenol	MM	scale	3:1	size	A3					
tolerance std				eng	Jun. Fan	Apr. 26, 2021							amphenol-icc.com	ecn no	ECN2474	rel level	RELEASE
TOLERANCES UNLESS OTHERWISE SPECIFIED				r vwr													
surface	linear	0.X	± 0.25	projection		MINI COOL EDGE CONNECTOR 0.6MM PITCH_1X4_ORTH, 85 Ohm, Gen5	product family MINI COOL EDGE	cat. no. C ME300560231104X	rev 6	sheet 7 of 7							
		0.XX	± 0.20														
		0.XXX	± 0.15														
	angular	0°	± 2°														