

DO NOT SCALE FROM THIS PRINT

TABLE 1 [F]		
ITEM	COMPONENT	-H
1	HEX NUT	SMA-NUT-001-F
2	LOCK WASHER	SMA-LWAS-001-F
3	GASKET	SMA-GKT-002
4	SUB ASSEMBLY	SUB-SMA-J-C-F-ST-SB3
5	SOCKET	SMA-SKT-004-H
6	INSULATOR	SMA-INS-017
7	CABLE BODY	SMA-J-C-F-ST-BH4-CBDY

GENDER
-J: JACK

TYPE
-C: CABLE

TERMINATION
-SB4: SEALED BULKHEAD (MH113 CABLE)

ORIENTATION
-ST: STRAIGHT

PLATING SPECIFICATION [F]
-H: 30µ" GOLD CENTER CONTACT, 3µ" GOLD OUTER CONTACT (SEE TABLE 1)

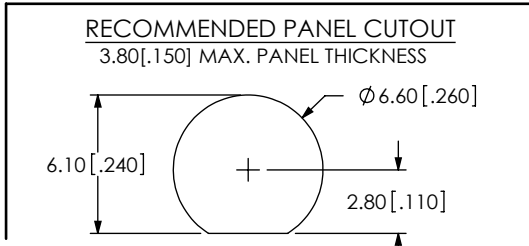
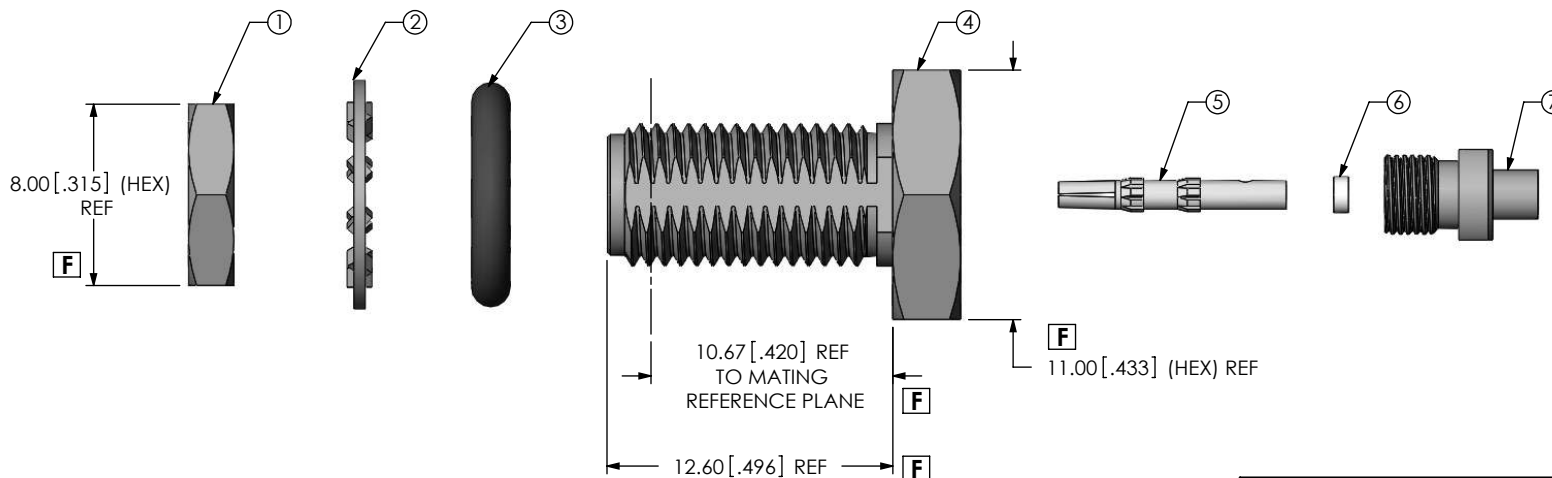

- [F]** NOTES:
- ⊕ REPRESENTS A CRITICAL DIMENSION.
 - NOTE DELETED.
 - NOTE DELETED.
 - NOTE DELETED.
 - PRODUCT TO BE PACKAGED PER PACKAGING STANDARD CO-HD-WI-3040-M.
 - NOTE DELETED.
 - NOTE DELETED.
 - NOTE DELETED.

UNLESS OTHERWISE SPECIFIED, DIMENSIONS ARE IN MILLIMETERS [INCHES]. TOLERANCES ARE:

DECIMALS ANGLES [F]

.X: ±0.3 [.01] 5°

.XX: ±0.13 [.005]

.XXX: ±0.051 [.0020]

PROPRIETARY NOTE
THIS DOCUMENT CONTAINS INFORMATION CONFIDENTIAL AND PROPRIETARY TO SAMTEC, INC. AND SHALL NOT BE REPRODUCED OR TRANSFERRED TO OTHER DOCUMENTS OR DISCLOSED TO OTHERS OR USED FOR ANY PURPOSE OTHER THAN THAT WHICH IT WAS OBTAINED WITHOUT THE EXPRESSED WRITTEN CONSENT OF SAMTEC, INC.

MATERIAL: DO NOT SCALE DRAWING SHEET SCALE: 3:1
SHELL, FERRULE, NUT, WASHER: BRASS
CONTACT: COPPER ALLOY
DIELECTRIC: PTFE

samtec

520 PARK EAST BLVD. NEW ALBANY, IN 47150
PHONE: 812-944-6733 FAX: 812-948-5047
e-Mail: info@SAMTEC.com code 55322

DESCRIPTION:
SMA STR S JACK BULKHEAD, MH113- 50 OHM

DWG. NO.
SMA-J-C-X-ST-SB4

BY: R MUSSER 04/17/2009 SHEET 1 OF 2

REVISION F

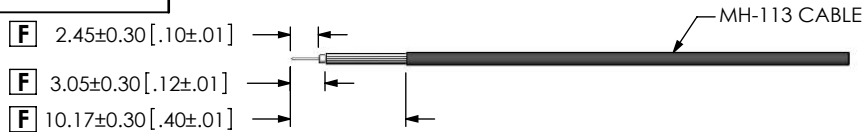

F
 IN PROCESS 1
 STRIP AND TIN INNER
 AND OUTER CONDUCTOR

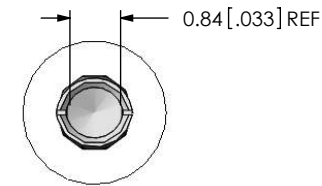

DETAIL 'B'
 SCALE 8:1

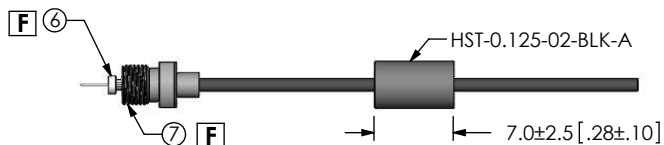

F
 IN PROCESS 2
 ADD HEAT SHRINK TUBE,
 REAR THREADED BODY,
 AND INSULATOR

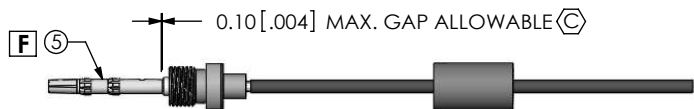

F
 IN PROCESS 3
 SOLDER SIGNAL PIN AND
 APPLY LOCTITE 680 TO THREADS

TIP OF CONTACT TO BE FLUSH
 WITH REFERENCE PLANE
 OR RECESSED 0.10 [.004] MAX.

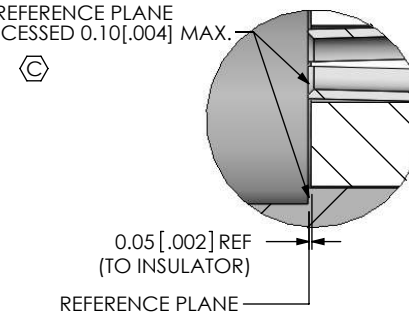

DETAIL 'A'
 SCALE 8:1

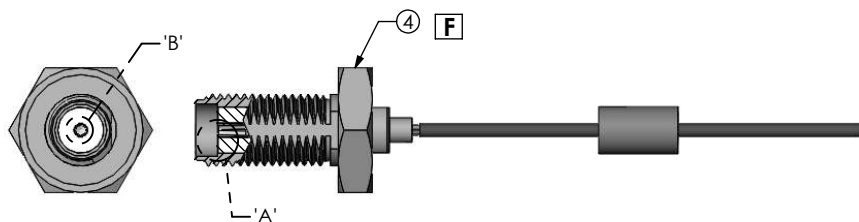

F
 IN PROCESS 4
 ADD SUB ASSEMBLY
 & TIGHTEN REAR-THREADED
 BODY TO 10 IN-LBS

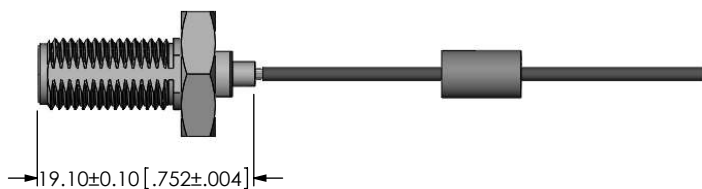

F
 IN PROCESS 5
 SOLDER SHIELD

F

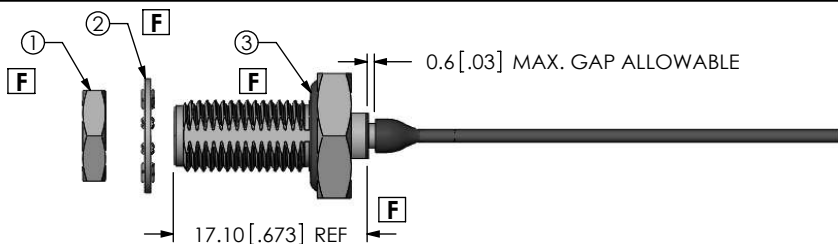

F
 IN PROCESS 6
 APPLY HEAT SHRINK TUBING
 & ADD GASKET

F:\DWG\MISC\MKTG\SMA-J-C-X-ST-SB4-MKT.SLDDRW

PROPRIETARY NOTE
 THIS DOCUMENT CONTAINS INFORMATION
 CONFIDENTIAL AND PROPRIETARY TO
 SAMTEC, INC. AND SHALL NOT BE REPRODUCED
 OR TRANSFERRED TO OTHER DOCUMENTS OR
 DISCLOSED TO OTHERS OR USED FOR ANY
 PURPOSE OTHER THAN THAT WHICH IT WAS
 OBTAINED WITHOUT THE EXPRESSED WRITTEN
 CONSENT OF SAMTEC, INC.

DO NOT SCALE DRAWING

SHEET SCALE: 3:2

samtec

520 PARK EAST BLVD, NEW ALBANY, IN 47150
 PHONE: 812-944-6733 FAX: 812-948-5047
 e-Mail: info@SAMTEC.com code 55322

DESCRIPTION:
 SMA STR S JACK BULKHEAD, MH113- 50 OHM

DWG. NO.
SMA-J-C-X-ST-SB4

BY: R MUSSER 04/17/2009 SHEET 2 OF 2