

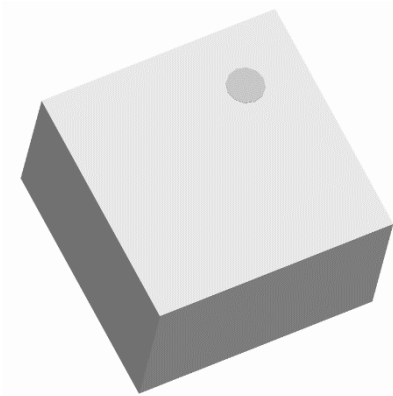

Ultra Low Profile 0404 Balun
50Ω to 100Ω Balanced



Description:

The BD3150N50100AHF is a low cost, low profile sub-miniature unbalanced to balanced transformer designed for differential inputs and output locations on modern chipsets in an easy to use surface mount package covering the MMDS and the low end of the UWB frequency range. The BD3150N50100AHF is ideal for high volume manufacturing and delivers higher performance than traditional ceramic baluns. The BD3150N50100AHF has an unbalanced port impedance of 50Ω and a 100Ω balanced port impedance. This transformation enables single ended signals to be applied to differential ports on modern integrated chipsets. The output ports have equal amplitude (-3dB) with 180 degree phase differential. The BD3150N50100AHF is available on tape and reel for pick and place high volume manufacturing.

Detailed Electrical Specifications:

Specifications subject to change without notice.

Features:	Parameter	ROOM (25°C)						Unit
		Min.	Typ.	Max	Min.	Typ.	Max	
• 3100 – 5000 MHz	Frequency	3100		5000	5000		7000	MHz
• 0.57mm Height Profile	Unbalanced Port Impedance		50			50		Ω
• 50 Ohm to 2 x 50 Ohm	Balanced Port Impedance		100			100		Ω
• Low Insertion Loss	Return Loss	13	15		10	14		dB
• UWB & MMDS	Insertion Loss*		0.7	0.9		0.7	0.9	dB
• Surface Mountable	Amplitude Balance		0.8	1.5		0.8	1.3	dB
• Tape & Reel	Phase Balance		3	7		15	20	Degrees
• Non-conductive Surface	CMRR		26			17		dB
• RoHS Compliant	Power Handling @85C			1.0			1.0	Watts
• Halogen Free	Power Handling @105C			0.6			0.6	Watts
	Operating Temperature	-55		+140	-55		+140	°C

* Insertion Loss stated at room temperature (Insertion Loss is approximately 0.1 dB higher at +85 °C)

Outline Drawing

Top View (Near-side)

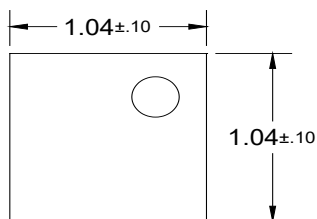

Side View

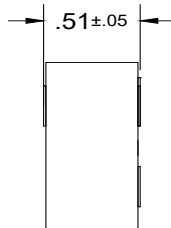

Bottom View (Far-side)

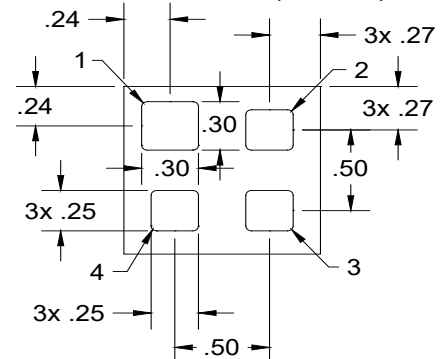

Pin	Designation
1	GND / DC Feed + RF GND
2	Unbalanced Port
3	Balanced Port
4	Balanced Port

Dimensions are in Millimeters
Mechanical Outline

Tolerances are Non-Cumulative

Typical Performance: 3000 MHz to 7000 MHz

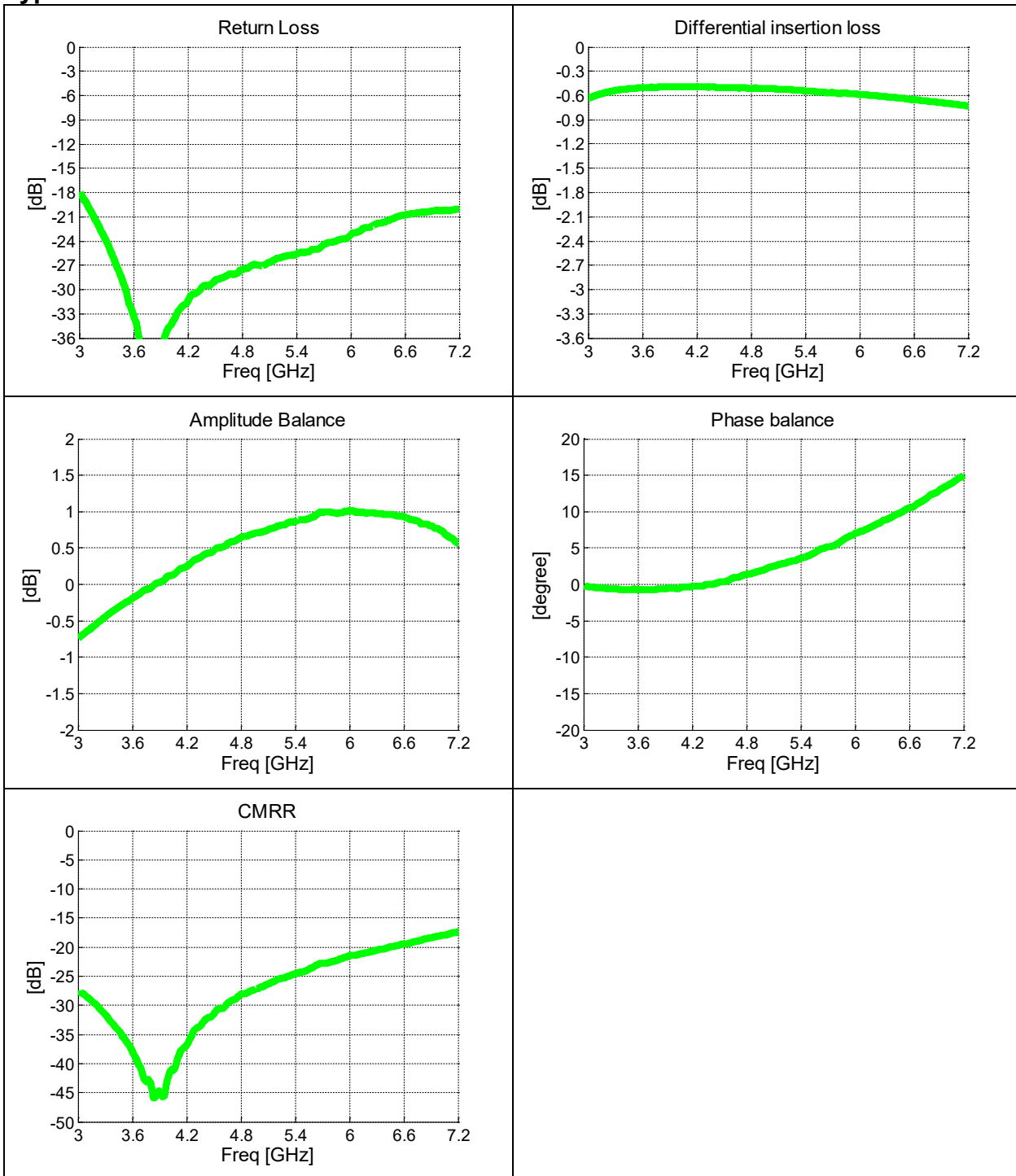

Wide Band Performance: 500 MHz. to 8500 MHz.

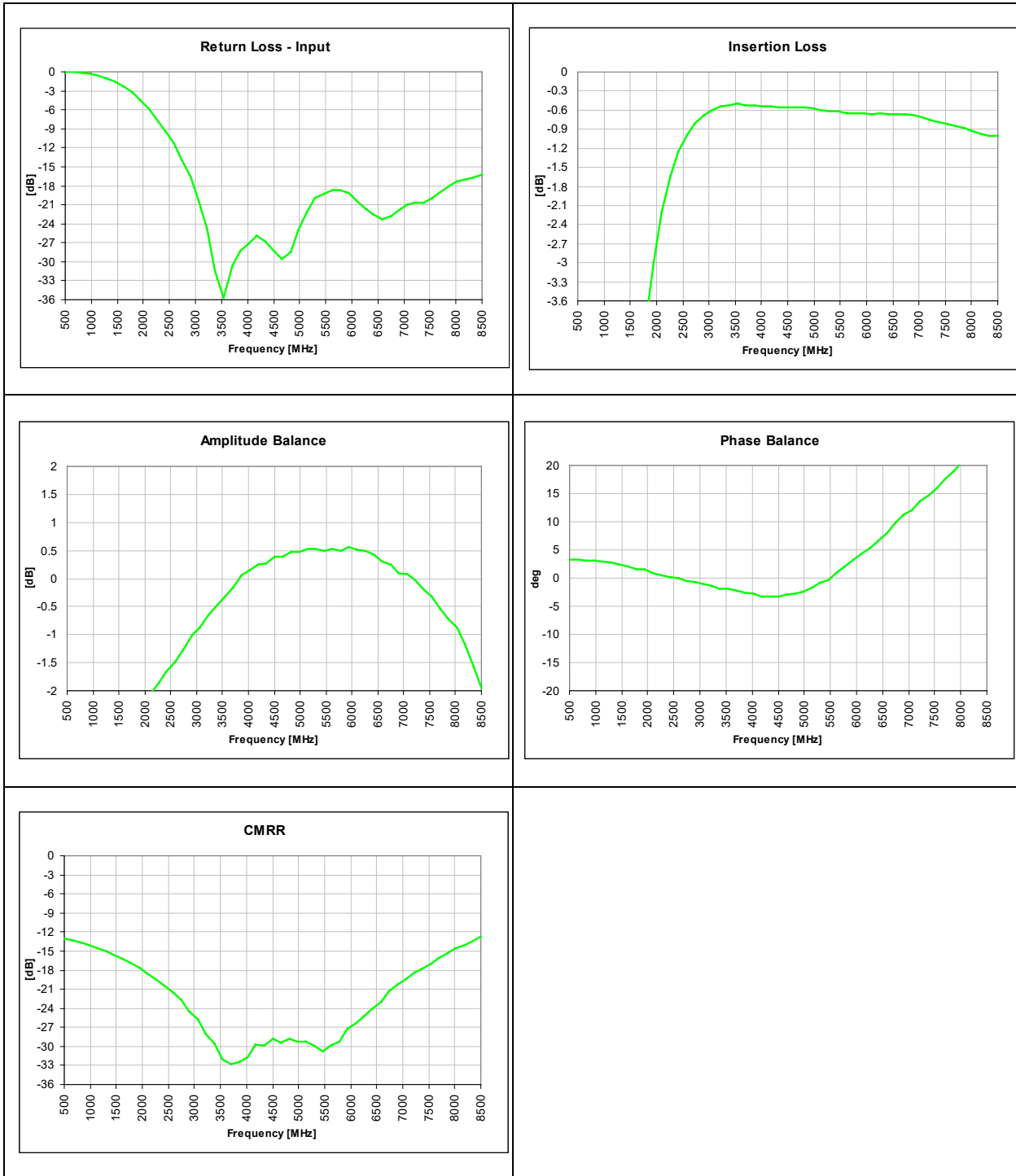

Mounting Configuration:

In order for Xinger surface mount components to work optimally, the proper impedance transmission lines must be used to connect to the RF ports. If this condition is not satisfied, insertion loss, Isolation and VSWR may not meet published specifications.

All of the Xinger components are constructed from organic PTFE based composites which possess excellent electrical and mechanical stability. Xinger components are compliant to a variety of ROHS and Green standards and ready for Pb-free soldering processes. Pads are Gold plated with a Nickel barrier.

An example of the PCB footprint used in the testing of these parts is shown below. In specific designs, the transmission line widths need to be adjusted to the unique dielectric coefficients and thicknesses as well as varying pick and place equipment tolerances.

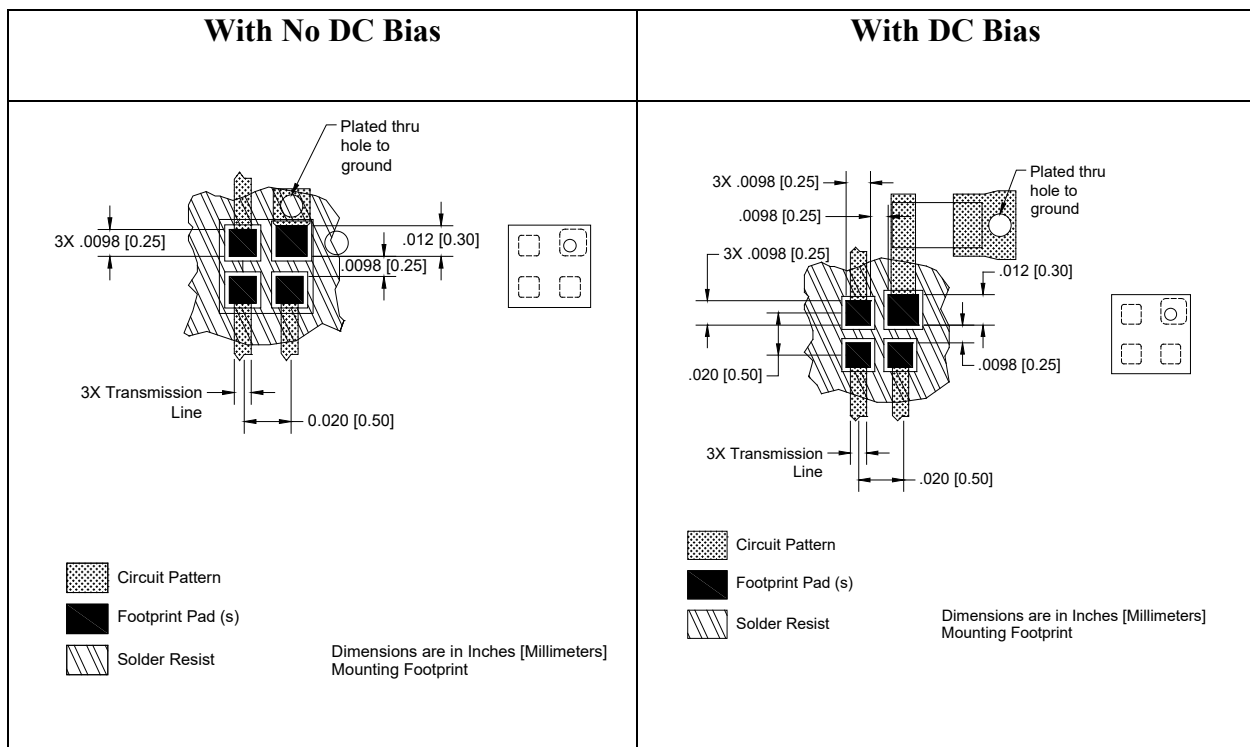

Packaging and Ordering Information

Parts are available in reel and are packaged per EIA 481-D. Parts are oriented in tape and reel as shown below. Minimum order quantities are 4000 per reel.

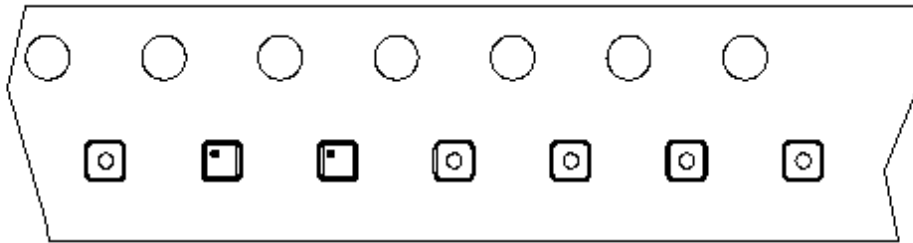

Direction of
Part Feed
(Unloading)

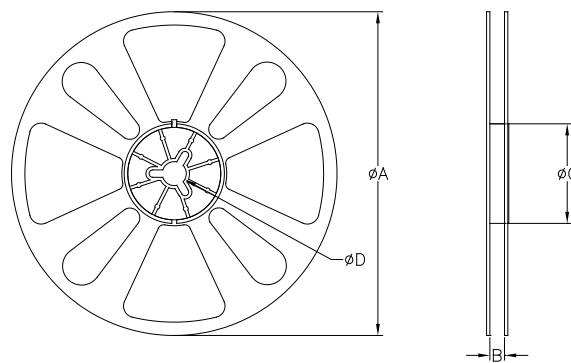

QUANTITY/REEL	REEL DIMENSIONS mm	
4000	øA	177.80
	B	8.00
	øC	50.80
	øD	13.00

Contact us:
rf&s_support@ttm.com