



**Thermal/Linear Intelligent Sensor  
PICtail™ Plus Daughter Board  
User's Guide**

---

**Note the following details of the code protection feature on Microchip devices:**

- Microchip products meet the specification contained in their particular Microchip Data Sheet.
- Microchip believes that its family of products is one of the most secure families of its kind on the market today, when used in the intended manner and under normal conditions.
- There are dishonest and possibly illegal methods used to breach the code protection feature. All of these methods, to our knowledge, require using the Microchip products in a manner outside the operating specifications contained in Microchip's Data Sheets. Most likely, the person doing so is engaged in theft of intellectual property.
- Microchip is willing to work with the customer who is concerned about the integrity of their code.
- Neither Microchip nor any other semiconductor manufacturer can guarantee the security of their code. Code protection does not mean that we are guaranteeing the product as "unbreakable."

Code protection is constantly evolving. We at Microchip are committed to continuously improving the code protection features of our products. Attempts to break Microchip's code protection feature may be a violation of the Digital Millennium Copyright Act. If such acts allow unauthorized access to your software or other copyrighted work, you may have a right to sue for relief under that Act.

---

Information contained in this publication regarding device applications and the like is provided only for your convenience and may be superseded by updates. It is your responsibility to ensure that your application meets with your specifications. MICROCHIP MAKES NO REPRESENTATIONS OR WARRANTIES OF ANY KIND WHETHER EXPRESS OR IMPLIED, WRITTEN OR ORAL, STATUTORY OR OTHERWISE, RELATED TO THE INFORMATION, INCLUDING BUT NOT LIMITED TO ITS CONDITION, QUALITY, PERFORMANCE, MERCHANTABILITY OR FITNESS FOR PURPOSE. Microchip disclaims all liability arising from this information and its use. Use of Microchip devices in life support and/or safety applications is entirely at the buyer's risk, and the buyer agrees to defend, indemnify and hold harmless Microchip from any and all damages, claims, suits, or expenses resulting from such use. No licenses are conveyed, implicitly or otherwise, under any Microchip intellectual property rights.

**Trademarks**

The Microchip name and logo, the Microchip logo, Accuron, dsPIC, KEELOQ, KEELOQ logo, MPLAB, PIC, PICmicro, PICSTART, rfPIC, SmartShunt and UNI/O are registered trademarks of Microchip Technology Incorporated in the U.S.A. and other countries.

FilterLab, Linear Active Thermistor, MXDEV, MXLAB, SEEVAL, SmartSensor and The Embedded Control Solutions Company are registered trademarks of Microchip Technology Incorporated in the U.S.A.

Analog-for-the-Digital Age, Application Maestro, CodeGuard, dsPICDEM, dsPICDEM.net, dsPICworks, dsSPEAK, ECAN, ECONOMONITOR, FanSense, In-Circuit Serial Programming, ICSP, ICEPIC, Mindi, MiWi, MPASM, MPLAB Certified logo, MPLIB, MPLINK, mTouch, PICkit, PICDEM, PICDEM.net, PICtail, PIC<sup>32</sup> logo, PowerCal, PowerInfo, PowerMate, PowerTool, REAL ICE, rfLAB, Select Mode, Total Endurance, WiperLock and ZENA are trademarks of Microchip Technology Incorporated in the U.S.A. and other countries.

SQTP is a service mark of Microchip Technology Incorporated in the U.S.A.

All other trademarks mentioned herein are property of their respective companies.

© 2008, Microchip Technology Incorporated, Printed in the U.S.A., All Rights Reserved.

 Printed on recycled paper.

**QUALITY MANAGEMENT SYSTEM**  
**CERTIFIED BY DNV**  
**== ISO/TS 16949:2002 ==**

*Microchip received ISO/TS-16949:2002 certification for its worldwide headquarters, design and wafer fabrication facilities in Chandler and Tempe, Arizona; Gresham, Oregon and design centers in California and India. The Company's quality system processes and procedures are for its PIC<sup>®</sup> MCUs and dsPIC<sup>®</sup> DSCs, KEELOQ<sup>®</sup> code hopping devices, Serial EEPROMs, microperipherals, nonvolatile memory and analog products. In addition, Microchip's quality system for the design and manufacture of development systems is ISO 9001:2000 certified.*



# THERMAL/LINEAR INTELLIGENT SENSOR PICtail™ PLUS DAUGHTER BOARD

---

---

## Table of Contents

---

---

<b>Preface</b> .....	<b>1</b>
<b>Chapter 1. Introduction</b>	
1.1 Overview .....	7
1.2 Board Setup .....	8
<b>Chapter 2. Hardware</b>	
2.1 Hardware Components .....	11
2.2 Functional Overview .....	15
<b>Chapter 3. Thermal Interface Demonstration</b>	
3.1 Overview .....	17
3.2 Hardware Setup .....	19
3.3 Software Setup .....	19
3.4 Running The Demonstration .....	21
<b>Chapter 4. Linear Interface Demonstration</b>	
4.1 Demonstration Overview .....	23
4.2 Demonstration Hardware Setup .....	24
4.3 Demonstration Software Setup .....	25
4.4 Running The Demonstration .....	26
<b>Appendix A. Schematics and Layout</b>	
<b>Index</b> .....	<b>33</b>
<b>Worldwide Sales and Service</b> .....	<b>34</b>

# Thermal/Linear Intelligent Sensor PICtail™ Plus Daughter Board

---

---

NOTES:



# THERMAL/LINEAR INTELLIGENT SENSOR PICtail™ PLUS DAUGHTER BOARD

---

---

## Preface

---

---

### NOTICE TO CUSTOMERS

All documentation becomes dated, and this manual is no exception. Microchip tools and documentation are constantly evolving to meet customer needs, so some actual dialogs and/or tool descriptions may differ from those in this document. Please refer to our web site ([www.microchip.com](http://www.microchip.com)) to obtain the latest documentation available.

Documents are identified with a “DS” number. This number is located on the bottom of each page, in front of the page number. The numbering convention for the DS number is “DSXXXXA”, where “XXXX” is the document number and “A” is the revision level of the document.

For the most up-to-date information on development tools, see the MPLAB® IDE on-line help. Select the Help menu, and then Topics to open a list of available on-line help files.

## INTRODUCTION

This chapter contains general information that will be useful to know before using the Thermal/Linear Intelligent Sensor PICtail™ Plus Daughter Board. Items discussed in this chapter include:

- Document Layout
- Conventions Used in this Guide
- Warranty Registration
- Recommended Reading
- The Microchip Web Site
- Development Systems Customer Change Notification Service
- Customer Support
- Document Revision History

## DOCUMENT LAYOUT

This document describes how to use the Thermal/Linear Intelligent Sensor PICtail™ Plus Daughter Board to provide the signal conditioning circuits necessary to interface thermal and linear sensor signals to a dsPIC® Digital Signal Controller (DSC) or a PIC24H Microcontroller (MCU). The manual layout is as follows:

- **Chapter 1. “Introduction”** – This chapter introduces the Thermal/Linear Intelligent Sensor PICtail™ Plus Daughter Board (also referred to as the Daughter Board throughout this document) and provides an overview of the features.
- **Chapter 2. “Hardware”** – This chapter identifies the major hardware components of the Daughter Board and provides a functional overview.
- **Chapter 3. “Thermal Interface Demonstration”** – This chapter describes a simple program that demonstrates how to use the Daughter Board to capture and process signals from a common type of temperature sensor: a K-type thermocouple.

## Thermal/Linear Intelligent Sensor PICtail™ Plus Daughter Board

---

- **Chapter 4. “Linear Interface Demonstration”** – This chapter describes a simple program that demonstrates how to use the Daughter Board to capture and process signals from any generic linear sensor through the Linear Sensor Interface.
- **Appendix A. “Schematics and Layout”** – This appendix provides detailed circuit schematics and board layout diagrams of the Daughter Board.

## CONVENTIONS USED IN THIS GUIDE

This manual uses the following documentation conventions:

### DOCUMENTATION CONVENTIONS

Description	Represents	Examples
<b>Arial font:</b>		
Italic characters	Referenced books	<i>MPLAB<sup>®</sup> IDE User's Guide</i>
	Emphasized text	...is the <i>only</i> compiler...
Initial caps	A window	the Output window
	A dialog	the Settings dialog
	A menu selection	select Enable Programmer
Quotes	A field name in a window or dialog	"Save project before build"
Underlined, italic text with right angle bracket	A menu path	<u><i>File&gt;Save</i></u>
Bold characters	A dialog button	Click <b>OK</b>
	A tab	Click the <b>Power</b> tab
N'Rnnnn	A number in verilog format, where N is the total number of digits, R is the radix and n is a digit.	4'b0010, 2'hF1
Text in angle brackets < >	A key on the keyboard	Press <Enter>, <F1>
<b>Courier New font:</b>		
Plain Courier New	Sample source code	#define START
	Filenames	autoexec.bat
	File paths	c:\mcc18\h
	Keywords	_asm, _endasm, static
	Command-line options	-Opa+, -Opa-
	Bit values	0, 1
	Constants	0xFF, 'A'
Italic Courier New	A variable argument	<i>file.o</i> , where <i>file</i> can be any valid filename
Square brackets [ ]	Optional arguments	mcc18 [options] <i>file</i> [options]
Curly brackets and pipe character: {   }	Choice of mutually exclusive arguments; an OR selection	errorlevel {0 1}
Ellipses...	Replaces repeated text	var_name [, var_name...]
	Represents code supplied by user	void main (void) { ... }

# Thermal/Linear Intelligent Sensor PICtail™ Plus Daughter Board

---

## WARRANTY REGISTRATION

Please complete the enclosed Warranty Registration Card and mail it promptly. Sending in the Warranty Registration Card entitles users to receive new product updates. Interim software releases are available at the Microchip web site.

## RECOMMENDED READING

This user's guide describes how to use Thermal/Linear Intelligent Sensor PICtail™ Plus Daughter Board. Other useful documents are listed below. The following Microchip documents are available and recommended as supplemental reference resources.

- *"dsPIC33FJ12GP201/202 Data Sheet"* (DS70264)
- *"MCP601/1R/2/3/4 2.7V to 6.0V Single Supply CMOS Op Amps"* (DS21314)
- *"MCP616/7/8/9 2.3V to 5.5V Micropower Bi-CMOS Op Amps"* (DS21613)
- *"TC1047/TC1047A Precision Temperature-to-Voltage Converter"* (DS21498)
- *"Explorer 16 Development Board User's Guide"* (DS51589)
- *"16-bit 28-pin Starter Development Board User's Guide"* (DS51656)

### Readme Files

For the latest information on using other tools, read the tool-specific Readme files in the Readmes subdirectory of the MPLAB IDE installation directory. The Readme files contain update information and known issues that may not be included in this user's guide.



## THE MICROCHIP WEB SITE

Microchip provides online support via our web site at [www.microchip.com](http://www.microchip.com). This web site is used as a means to make files and information easily available to customers. Accessible by using your favorite Internet browser, the web site contains the following information:

- **Product Support** – Data sheets and errata, application notes and sample programs, design resources, user's guides and hardware support documents, latest software releases and archived software
- **General Technical Support** – Frequently Asked Questions (FAQs), technical support requests, online discussion groups, Microchip consultant program member listing
- **Business of Microchip** – Product selector and ordering guides, latest Microchip press releases, listing of seminars and events, listings of Microchip sales offices, distributors and factory representatives

## DEVELOPMENT SYSTEMS CUSTOMER CHANGE NOTIFICATION SERVICE

Microchip's customer notification service helps keep customers current on Microchip products. Subscribers will receive e-mail notification whenever there are changes, updates, revisions or errata related to a specified product family or development tool of interest.

To register, access the Microchip web site at [www.microchip.com](http://www.microchip.com), click on Customer Change Notification and follow the registration instructions.

The Development Systems product group categories are:

- **Compilers** – The latest information on Microchip C compilers and other language tools. These include the MPLAB C18 and MPLAB C30 C compilers; MPASM™ and MPLAB ASM30 assemblers; MPLINK™ and MPLAB LINK30 object linkers; and MPLIB™ and MPLAB LIB30 object librarians.
- **Emulators** – The latest information on Microchip in-circuit emulators. This includes the MPLAB ICE 2000, MPLAB ICE 4000, and MPLAB REAL ICE™
- **In-Circuit Debuggers** – The latest information on the Microchip in-circuit debugger, MPLAB ICD 2.
- **MPLAB® IDE** – The latest information on Microchip MPLAB IDE, the Windows® Integrated Development Environment for development systems tools. This list is focused on the MPLAB IDE, MPLAB SIM simulator, MPLAB IDE Project Manager and general editing and debugging features.
- **Programmers** – The latest information on Microchip programmers. These include the MPLAB PM3 and PRO MATE II device programmers and the PICSTART® Plus and PICKit™ 1 development programmers.

# Thermal/Linear Intelligent Sensor PICtail™ Plus Daughter Board

---

---

## CUSTOMER SUPPORT

Users of Microchip products can receive assistance through several channels:

- Distributor or Representative
- Local Sales Office
- Field Application Engineer (FAE)
- Technical Support

Customers should contact their distributor, representative or field application engineer (FAE) for support. Local sales offices are also available to help customers. A listing of sales offices and locations is included in the back of this document.

Technical support is available through the web site at: <http://support.microchip.com>

## DOCUMENT REVISION HISTORY

### Revision A (December 2008)

This is the initial release of this document.



# THERMAL/LINEAR INTELLIGENT SENSOR PICtail™ PLUS DAUGHTER BOARD

---

---

## Chapter 1. Introduction

---

---

Thank you for purchasing Microchip Technology's Thermal/Linear Intelligent Sensor PICtail™ Plus Daughter Board. This board provides the signal conditioning circuits necessary to interface thermal and linear sensor signals to a dsPIC® Digital Signal Controller (DSC) or a PIC24H microcontroller (MCU).

The Thermal/Linear Intelligent Sensor PICtail Plus Daughter Board is used with either the Explorer 16 Development Board or the 16-bit 28-pin Starter Development Board to demonstrate the acquisition, analog-to-digital conversion (dsPIC DSC or PIC24H devices) and signal processing of typical sensor signals using the architectural and peripheral features of dsPIC DSC devices.

This chapter introduces the Thermal/Linear Intelligent Sensor PICtail Plus Daughter Board (simplified as Daughter Board throughout this document) and provides an overview of the features. Topics covered include:

- Overview
- Board Setup

### 1.1 OVERVIEW

The Daughter Board fits into the expansion slot on the Explorer 16 Development Board and interfaces between an external sensor and the dsPIC33F or PIC24H device on the Explorer 16 Development Board. The Daughter Board is intended to support the development of intelligent sensor processing applications using Microchip's 16-bit DSC and MCU device families.

Alternately, the Daughter Board may be plugged into the pin header on the 16-bit 28-pin Starter Development Board using connector J2 (refer to Figure 2-1 in **Chapter 2. "Hardware"** for the location of this connector).

The differential output signals from the thermocouple (not provided with the Daughter Board) are amplified, passed through an anti-aliasing filter and routed to the Analog-to-Digital Converter (ADC) module on the dsPIC33F or PIC24H device for software processing. A TC1047A temperature sensor IC is also provided on the board. The output of this temperature sensor is passed through another anti-aliasing filter and routed to the ADC.

The Daughter Board also provides a generic linear signal interface to which any single-ended sensor output (or even an artificially synthesized signal) can be supplied. Just like the thermocouple and TC1047A output signals, this linear signal is conditioned using an anti-aliasing filter, but it is also level-shifted in order to allow bipolar sensor signals to be sampled by the unipolar ADC on the dsPIC33F or PIC24H device.

The Explorer 16 Development Board (or 16-bit 28-pin Starter Development Board) supplies power to the Daughter Board.

The Daughter Board is shown in Figure 1-1. This document reflects the usage of the Daughter Board with the Explorer 16 Development Board; however, the 16-bit 28-pin Starter Development Board has similar set up requirements.

# Thermal/Linear Intelligent Sensor PICtail™ Plus Daughter Board

FIGURE 1-1: THERMAL/LINEAR INTELLIGENT SENSOR PICtail™ PLUS DAUGHTER BOARD

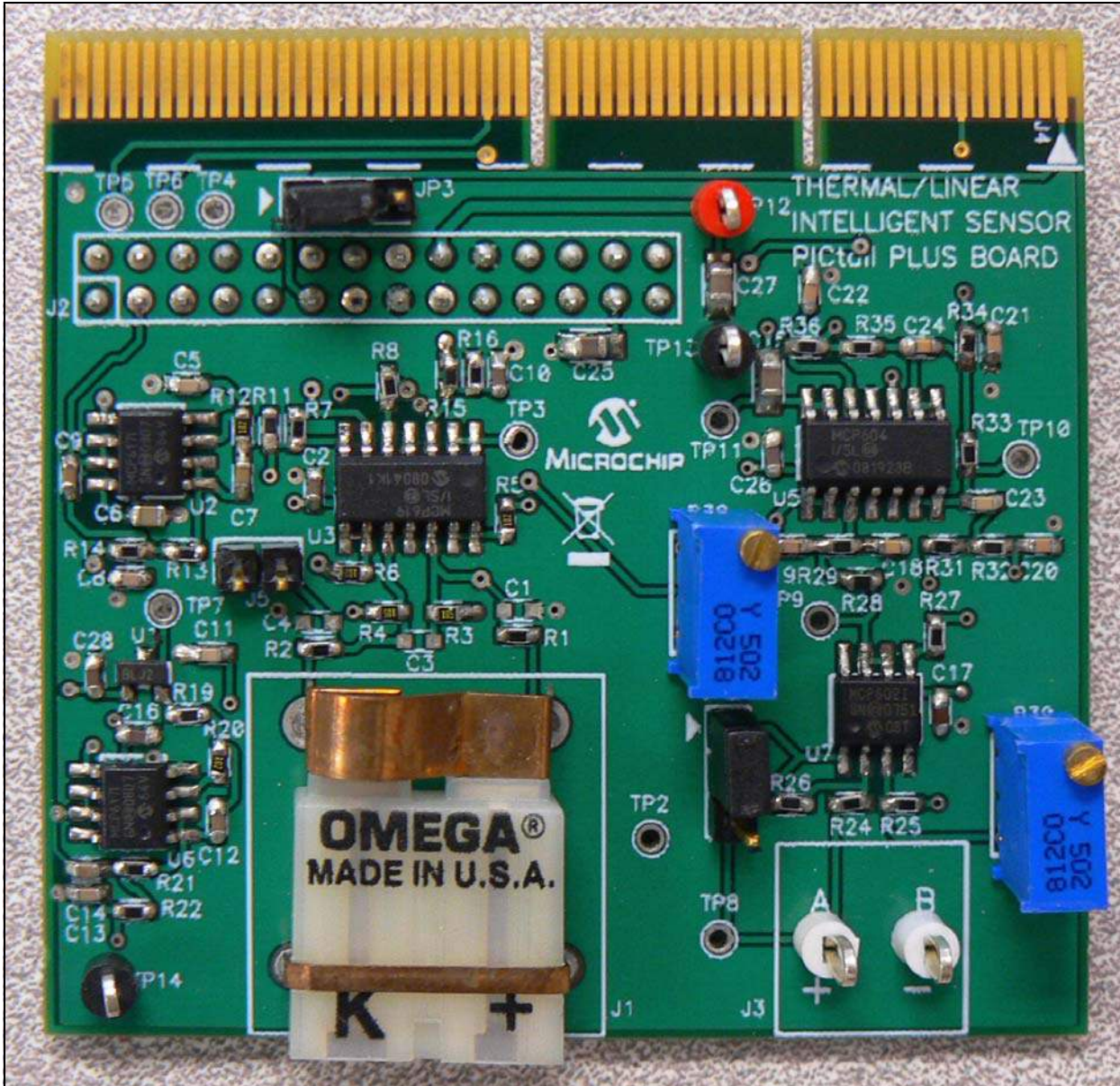

## 1.2 BOARD SETUP

Figure 1-2 shows a photograph of the Daughter Board plugged into an Explorer 16 Development Board. A K-type thermocouple is connected to the Daughter Board. For demonstration purposes, a portable function generator is also shown connected to the Daughter Board. In a real application development environment, this may be substituted for any other linear sensor signal.

A 9V power supply and the MPLAB® REAL ICE™ in-circuit emulator are plugged into the Explorer 16 Development Board. MPLAB REAL ICE in-circuit emulator is required to operate the demonstration programs provided with the board package; however, for actual usage an MPLAB ICD 2 or any other programmer/debugger may be used. The two demonstration programs show the capture and processing of signals obtained from the thermocouple interface and from the generic linear signal interface, respectively.

FIGURE 1-2: THERMAL/LINEAR INTELLIGENT SENSOR PICtail™ PLUS DAUGHTER BOARD SETUP

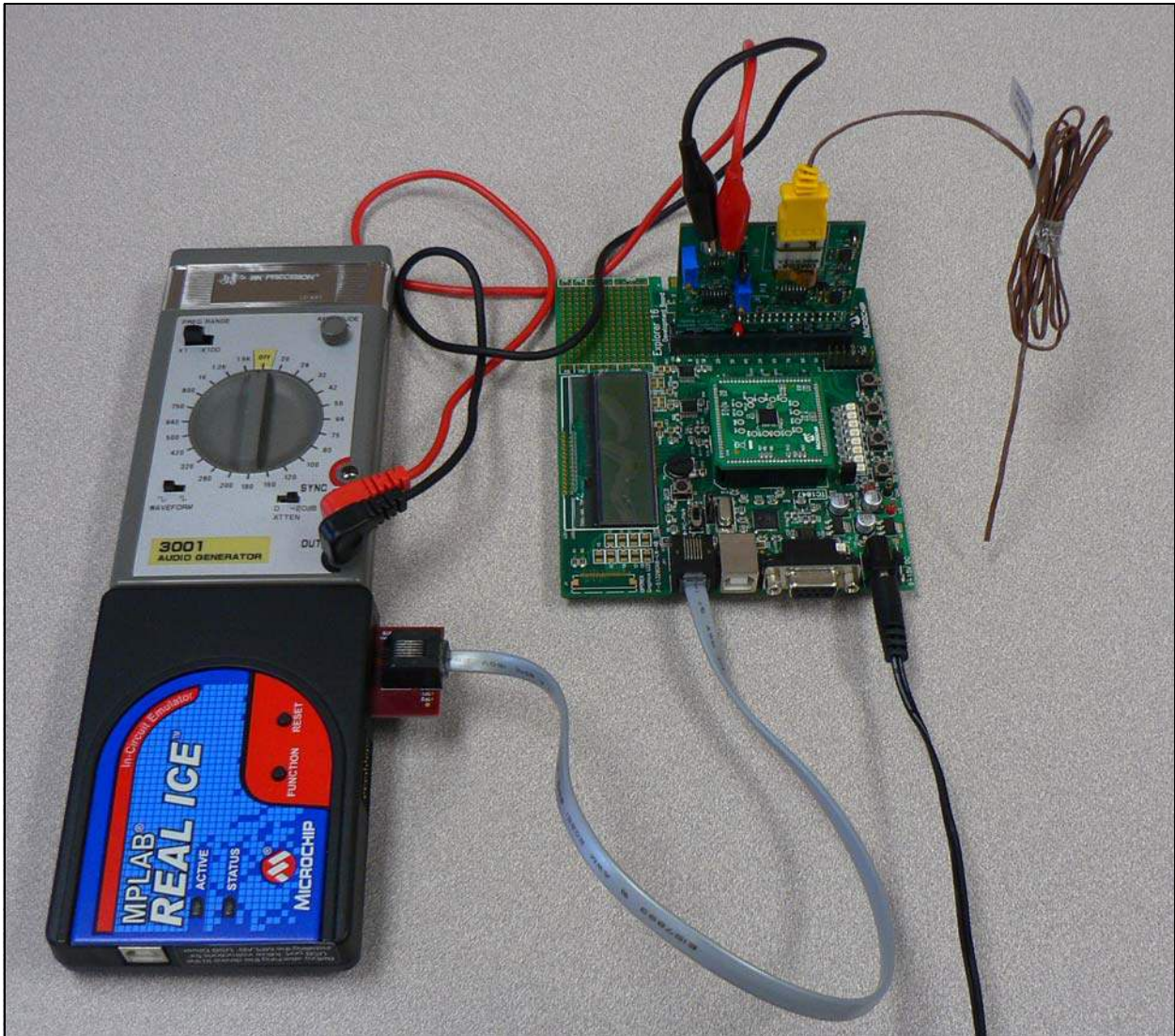

# Thermal/Linear Intelligent Sensor PICtail™ Plus Daughter Board

---

---

NOTES:



# THERMAL/LINEAR INTELLIGENT SENSOR PICtail™ PLUS DAUGHTER BOARD

---

---

## Chapter 2. Hardware

---

---

This chapter identifies the major hardware components of the Thermal/Linear Intelligent Sensor PICtail Plus Daughter Board and provides a functional overview. Topics covered include:

- Hardware Components
- Functional Overview

### 2.1 HARDWARE COMPONENTS

Figure 2-1 identifies the key hardware components of the Daughter Board. The numbered board components are described in Table 2-1.

# Thermal/Linear Intelligent Sensor PICtail™ Plus Daughter Board

FIGURE 2-1: DAUGHTER BOARD HARDWARE COMPONENTS

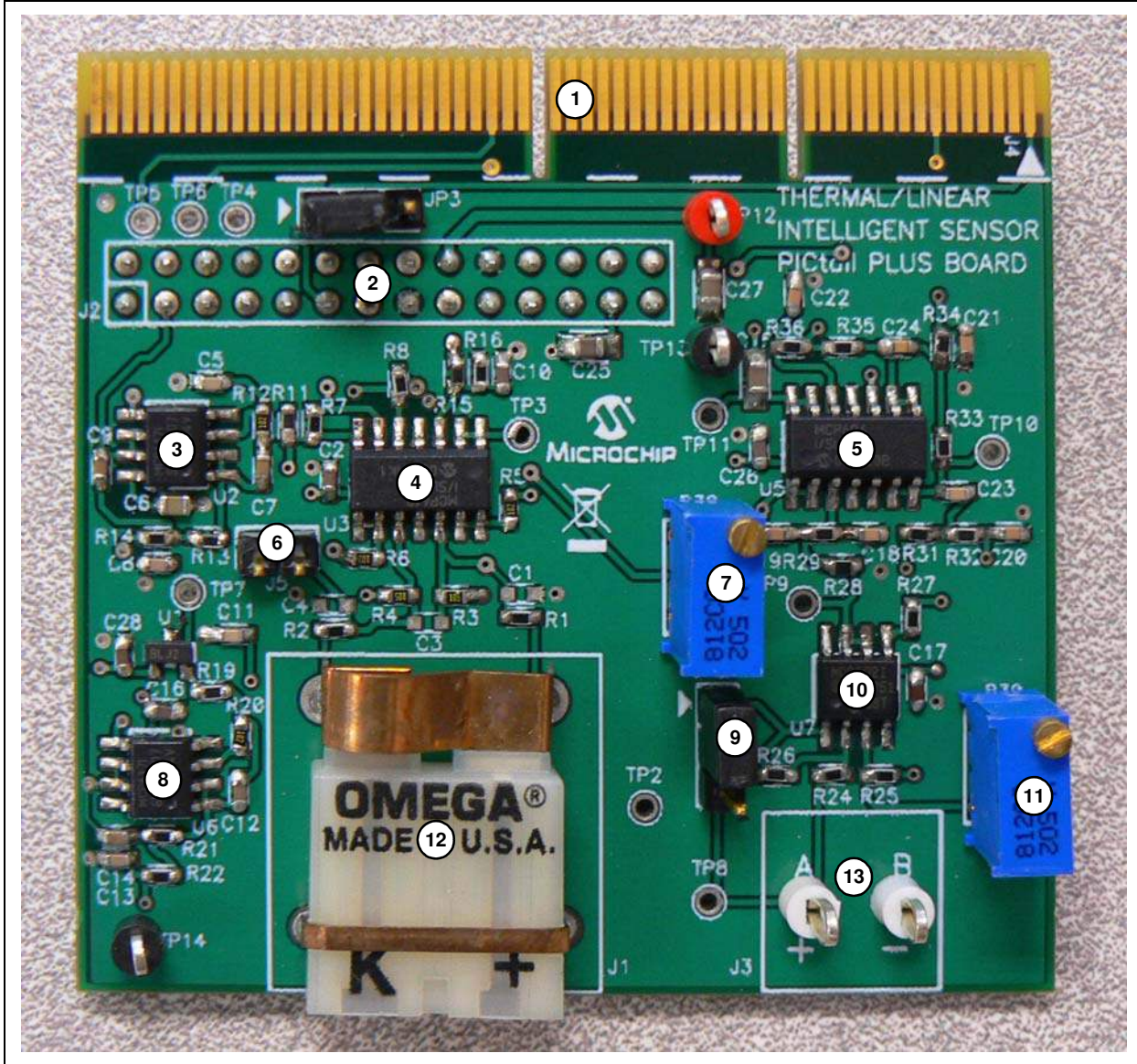

TABLE 2-1: DAUGHTER BOARD COMPONENTS

Number	Name	Component Description
1	J4	Explorer 16 PICtail™ Plus connector
2	J2	16-bit 28-pin Starter Development Board connector
3	U2	Anti-aliasing low-pass filter for thermocouple signal
4	U3	Differential amplifier for thermocouple signal
5	U5	Anti-aliasing low-pass filter for linear signal
6	J5	Jumper for input offset calibration of differential amplifier
7	R38	Potentiometer for differential amplifier output offset adjustment
8	U6	Anti-aliasing low-pass filter for temperature sensor IC signal
9	JP2	Jumper to include or bypass level shifter
10	U7	Level shifter for linear signal
11	R30	Potentiometer for level shifter adjustment
12	J1	Thermocouple connector
13	J3	Linear signal connector



## 2.1.1 Explorer 16 PICtail Plus Connector (J4)

The Daughter Board connects to the Explorer 16 Development Board using edge connector J3. The Daughter Board uses the following Explorer 16 signals:

- +3.3V power
- Ground
- dsPIC33F or PIC24H device ADC module inputs (3 inputs)

## 2.1.2 16-bit 28-pin Starter Development Board Connector (J2)

This connector allows the Daughter Board to be connected to Microchip's 16-bit 28-pin Starter Development Board. The Daughter Board uses the following Explorer 16 signals:

- +3.3V power
- Ground
- dsPIC33F or PIC24H device ADC module inputs (3 inputs)

## 2.1.3 Anti-Aliasing Low-Pass Filter for Thermocouple Signal (U2)

The anti-aliasing low-pass filter uses the two op amps in the MCP617 dual op amp IC. The output of the differential amplifier uses an anti-aliasing low-pass 4th-order Sallen-Key structure to filter the signal and provide a cut-off frequency of 3300 Hz.

## 2.1.4 Differential Amplifier for Thermocouple Signal (U3)

The thermocouple differential amplifier uses three op amps in the MCP619 quad op amp IC. The fourth op amp buffers the reference voltage provided to the differential amplifier as well as the level shifter circuit. The output from a thermocouple is a pair of analog voltage signals. The differential amplifier converts this signal pair into a single-ended voltage signal for the on-chip ADC in the dsPIC33F or PIC24H device. The external resistors R5, R6, R7 and R8 have been selected to provide an amplifier gain of 249.

## 2.1.5 Anti-Aliasing Low-Pass Filter for Linear Signal (U5)

The anti-aliasing low-pass filter uses the two op amps in the MCP617 dual op amp IC. The output of the level shifter circuit uses an anti-aliasing low-pass 8th-order Sallen-Key structure to filter the signal and provide a cut-off frequency of 3300 Hz.

## 2.1.6 Jumper for Offset Calibration of Differential Amplifier (J5)

The jumper J5 can be used as a possible method of calibrating the output offset voltage of the differential amplifier. To do this, install the jumper and measure the output voltage at test point TP4.

## 2.1.7 Potentiometer for Differential Amplifier Output Offset Adjustment (R38)

The constant output offset voltage can be adjusted manually by the user by rotating the screw on potentiometer R38, either clockwise or counterclockwise. Rotating the potentiometer screw clockwise increases the offset, whereas rotating it in a counterclockwise direction decreases the offset. The offset can range from 0V to 1.65V.

## 2.1.8 Anti-Aliasing Low-Pass Filter for Temperature Sensor IC Signal (U6)

The anti-aliasing low-pass filter uses the two op amps in the MCP617 dual op amp IC. The output of the differential amplifier uses an anti-aliasing low-pass 4th-order Sallen-Key structure to filter the signal and provide a cut-off frequency of 3300 Hz.

## **2.1.9 Jumper to Include or Bypass Level Shifter (JP2)**

The jumper JP2 determines whether the level shifter circuit will be included in the linear signal chain or bypassed completely. To include the level shifter, install the jumper in the 1-2 position (indicated by the arrow marked adjacent to the jumper on the Daughter Board). To bypass the level shifter and supply the linear input signal directly to the anti-aliasing low-pass filter, install the jumper in the 2-3 position.

## **2.1.10 Level Shifter for Linear Signal (U7)**

The level shifter circuit is implemented using the MCP602 dual op amp IC. Op amp A works in conjunction with the external components to provide the required level shift, and op amp B serves as a buffer.

## **2.1.11 Potentiometer for Level Shifter Adjustment (R30)**

Users can manually adjust the level provided by the level shifter by rotating the screw on the potentiometer R30. The level of the signal mid-point can range from 0V to 3.3V, depending on the potentiometer adjustment. Rotating the potentiometer screw clockwise increases the signal level, whereas rotating it in a counterclockwise direction decreases the signal level.

## **2.1.12 Thermocouple Connector (J1)**

The Daughter Board contains a standard K-type thermocouple connector labeled J1. A thermocouple with the appropriate receptacle can be inserted directly into the connector.

## **2.1.13 Linear Signal Connector (J3)**

Connector J3 contains a pair of test points, which allow users to supply an external linear signal, either from a real sensor or generated artificially for development purposes.

## 2.2 FUNCTIONAL OVERVIEW

The block diagram shown in Figure 2-2 illustrates the operation of the Daughter Board.

**FIGURE 2-2: DAUGHTER BOARD BLOCK DIAGRAM**

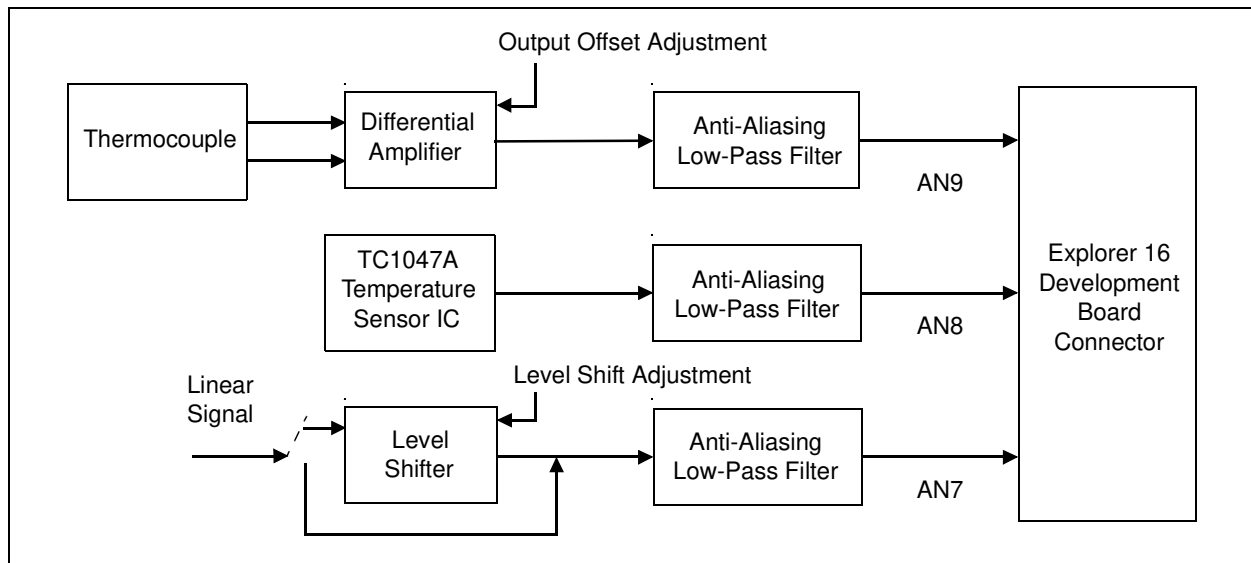

### 2.2.1 Thermocouple Signal Conditioning

The incoming signals come from the differential voltage outputs of a thermocouple (not included with the Daughter Board) plugged into thermocouple connector J1. These signals are amplified by a differential amplifier implemented using three operational amplifiers in an MCP619 quad op amp device. The external components of the differential amplifier have been selected to provide amplification by a factor of 249.

The fourth op amp in this device is used to provide a constant 1.65V voltage reference to the differential amplifier as well as to the level shifter circuit (described in **Section 2.2.3 "Linear Sensor Signal Conditioning"**). Depending on application requirements, the user can adjust the output offset of the differential amplifier by adjusting the potentiometer R38.

Some users may choose to perform input offset calibration of the differential amplifier. This can be accomplished by mounting a capacitor (C3) and installing a jumper on J5.

The single-ended output of the differential amplifier is routed to an MCP617 dual op amp device. The two op amps in this device are configured to serve as an anti-aliasing low-pass filter, in a 4th-order Sallen-Key structure. This limits the bandwidth of the input signal to approximately 3300 Hz. The output of this filter is routed to pin 69 of the PICtail Plus interface header J4 on the Explorer 16 Development Board, for analog-to-digital conversion and further processing by a dsPIC33F or PIC24H device. For a dsPIC33FJ12GP202 Plug-in Module (PIM), this pin is routed to the ADC input AN9 of the dsPIC33FJ12GP202 device.

### 2.2.2 Temperature Sensor IC Signal Conditioning

A TC1047A temperature sensor IC is provided on the Daughter Board. The output voltage of the temperature sensor IC has an amplitude of 10 mV per degree Celsius and a constant output voltage offset of 500 mV. This signal is primarily intended to ease the implementation of cold junction compensation in the application software by providing an approximate reference for the temperature of the Daughter Board itself. However, the TC1047A can also be used independently as an alternative temperature sensor.

The single-ended output of the TC1047A device is routed to an MCP617 dual op amp device. The two op amps in this device are configured to serve as an anti-aliasing low-pass filter, identical to the filter used in the thermocouple signal conditioning circuit. The output of this filter is routed to pin 70 of the PICtail Plus interface header J4 on the Explorer 16 Development Board, for analog-to-digital conversion and further processing by a dsPIC33F or PIC24H device. For a dsPIC33FJ12GP202 PIM, this pin is routed to the ADC input AN8 of the dsPIC33FJ12GP202 device.

### 2.2.3 Linear Sensor Signal Conditioning

The Daughter Board also contains a generic signal interface for any linear sensor signals with a maximum peak-to-peak voltage of 3.3V. The signal can come from a sensor located external to the board; alternately, it can simply be an artificially generated signal (e.g., from a function generator) used to model a particular sensor output during application development. Whatever the source, the signal can be supplied to pins 1 and 2 on connector J3, or only supplied to pin 1 with pin 2 grounded.

Often, the signal may be bipolar, which means it can have values less than 0V. Since the signal is required to be sampled by the on-chip ADC on a dsPIC33F or PIC24H device, its level must be shifted up such that the signal becomes unipolar, so that it stays above 0V at all times. This functionality, illustrated in Figure 2-3, is provided by a level shifter circuit on the Daughter Board. The level shifter is implemented using one op amp of an MCP602 dual op amp device. This level shifter circuit is essentially an inverting differential amplifier, with the non-inverting input derived from the positive voltage rail. The level of the signal midpoint can be adjusted (between 0V and 3.3V) using potentiometer R30, and the level shifter circuit can be included or bypassed by installing a jumper in the 1-2 position (indicated on the Daughter Board by an arrow beside the jumper) or the 2-3 position, respectively, of jumper JP2.

The other op amp in the MCP602 acts as a buffer. A buffer is essentially a non-inverting amplifier with unity gain, and prevents the output circuit from loading the input circuit and distorting the signals as a result.

The output of the buffer is provided to an anti-aliasing low-pass filter, implemented as an 8th-order Sallen-Key structure. The output of this filter is routed to pin 38 of the PICtail Plus interface header J4 on the Explorer 16 Development Board, for analog-to-digital conversion and further processing by a dsPIC33F or PIC24H device. For a dsPIC33FJ12GP202 PIM, this pin is routed to the ADC input AN7 of the dsPIC33FJ12GP202 device.

**FIGURE 2-3: LEVEL SHIFTER OPERATION**

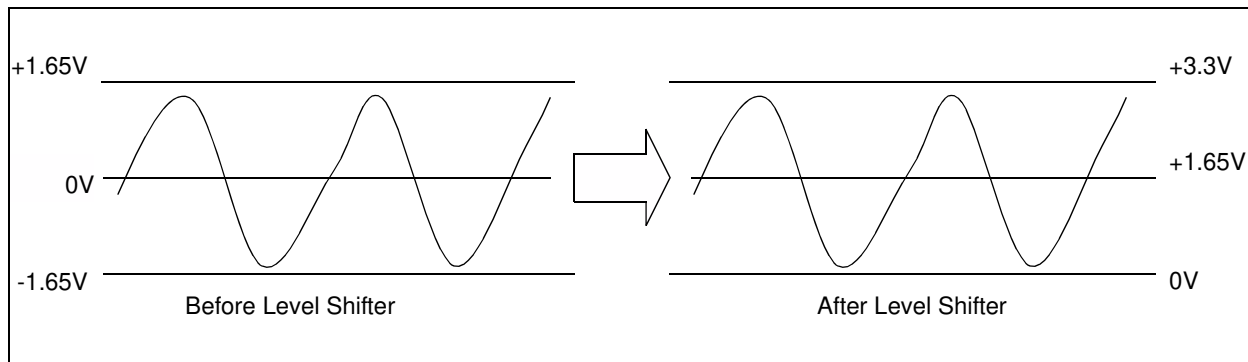

## Chapter 3. Thermal Interface Demonstration

This chapter describes a simple program that demonstrates how to use the Daughter Board to capture and process signals from a common type of temperature sensor: a K-type thermocouple. Topics covered include:

- Overview
- Hardware Setup
- Software Setup
- Running The Demonstration

### 3.1 OVERVIEW

The CD that accompanies the Daughter Board contains a thermal interface demonstration application. All files pertaining to this demonstration are located in the following folder on the CD: `demo\Thermal Interface Demo`.

As shown in Figure 3-1, this sample application uses the Daughter Board to perform signal conditioning on the output of a K-type thermocouple, and uses the on-chip ADC of the dsPIC33FJ12GP202 device to convert the signal to a digital form.

The TC1047A temperature sensor IC on the Daughter Board is utilized to perform cold junction compensation in the application software. In addition, the application software uses the Digital Signal Processing (DSP) features of the dsPIC33F architecture to perform averaging and linearization of the converted sensor output samples.

Finally, the application converts the linearized voltage to its corresponding temperature equivalent, and displays this temperature in the Watch window and the Data Monitor and Control Interface (DMCI) using the MPLAB REAL ICE in-circuit emulator.

**FIGURE 3-1: THERMAL INTERFACE DEMONSTRATION**

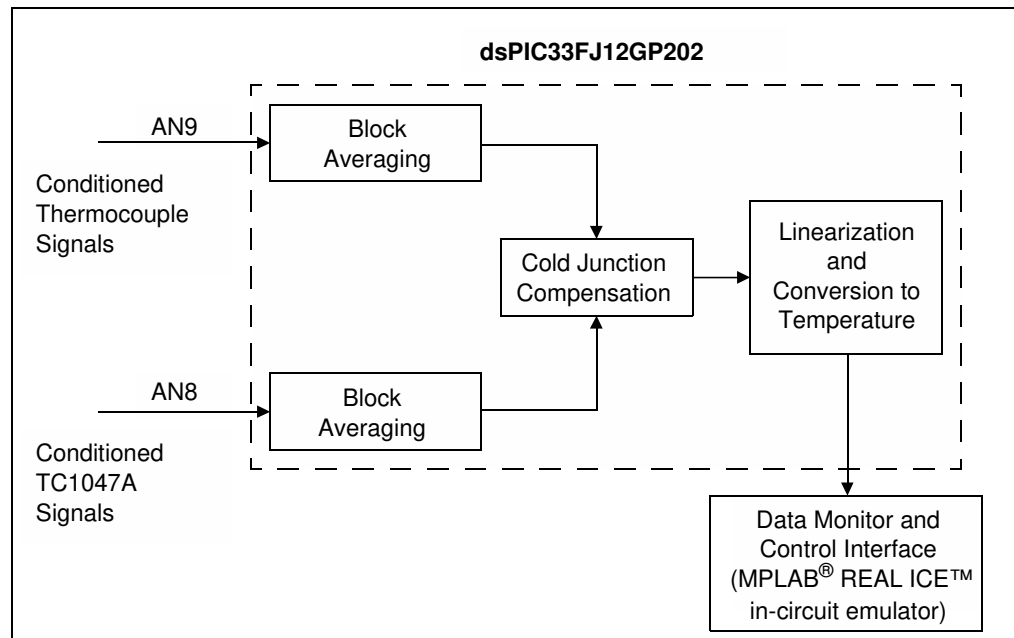

The demonstration program consists of the following basic software elements:

- ADC Driver
- Averaging and Cold Junction Compensation Function
- Linearization

### 3.1.1 ADC Driver

The ADC driver reads the incoming signals from the thermocouple and the temperature sensor IC (after signal conditioning by the differential amplifier and anti-aliasing filter) on the 12-bit ADC channels AN9 and AN8, respectively. The source code file, `adcDrv1.c`, contains the ADC initialization function `initAdc1()` as well as the ADC Interrupt Service Routine (ISR).

The thermocouple signal samples are stored in a 128-sample array named `TC_Buff` and the TC1047A signal samples are stored in a 128-sample array named `CJC_Buff`.

### 3.1.2 Averaging and Cold Junction Compensation Function

The thermocouple samples stored in `TC_Buff` are added with the running sum being accumulated in accumulator A. Similarly, accumulator B is used to add all of the TC1047A samples stored in `CJC_Buff`. This accumulation is performed very efficiently using a `DO` loop instruction.

Note that the voltage generated by the thermocouple does not compensate for the temperature of the cold junction (which refers to the ends of the thermocouple that are plugged into the connector on the board). The temperature of the cold junction is typically very close to the temperature of the board surface; therefore, the TC1047A temperature sensor IC samples are used as the cold junction reference. Since accumulators A and B now contain the running sum of the thermocouple and TC1047A respectively, the two accumulators are added to each other using the 32-bit accumulator-to-accumulator `ADD` instruction.

Finally, the `SAC` instruction is utilized to store the result back into the variable `AverageVoltage`. Moreover, as part of the accumulator write-back, the data is shifted right by 7 bits, resulting in a division by 128. Therefore, the variable `AverageVoltage` now contains the average cold-junction-compensated sensor voltage output.

### 3.1.3 Linearization

For many temperature sensors, including thermocouples, the sensor output does not have an exact linear relationship to the physical quantity (temperature, in this case) being measured. Therefore, the output voltage must be linearized. A common method of linearizing sensor output voltages is to compute a standard polynomial. This demonstration utilizes a standardized polynomial for K-type thermocouples, as shown in Equation 3-1.

#### EQUATION 3-1: K-TYPE THERMOCOUPLE POLYNOMIAL

$$V_O = (25.132785) \cdot V_{IN} - (60.883423) \cdot V_{IN}^2 + \dots$$

Since the voltages and higher-order coefficients are small in magnitude in this application, the demonstration only computes a 2nd-order polynomial and neglects the higher-order coefficients. This operation is performed by the `Linearize()` function in the `Linearize.s` source file. Dual-operand DSP instructions such as `MAC` and `MPY` have been utilized to compute this polynomial in only seven instruction cycles, and the linearized result is stored in the variable `LinearOut`.

Finally, the main application converts the linearized voltage into a floating point variable named `Temperature`, which provides the absolute temperature of the thermocouple junction in degrees Celsius.

## 3.2 HARDWARE SETUP

To use this demonstration, you will need the following hardware:

- Thermal/Linear Intelligent Sensor PICtail™ Plus Daughter Board
- Explorer 16 Development Board
- dsPIC33FJ12GP202 Plug-In Module (MA330015)
- PC running the following software:
  - MPLAB IDE software, version 8.10 or higher
  - MPLAB C30 compiler, version 3.01 or higher
- MPLAB REAL ICE in-circuit emulator
- Any standard K-type thermocouple with a connector

Before programming or running the demonstration application, make the following hardware connections:

1. Plug in a K-type thermocouple into the J1 socket of the Daughter Board.
2. Insert the Daughter Board into the J5 socket of the Explorer 16 Development Board.
3. On the Explorer 16 Development Board, insert a dsPIC33FJ12GP202 PIM.
4. On the Explorer 16 Development Board, make sure that switch S2 is set to the PIM position and the jumper J7 is set to the PIC24 position.
5. Connect the Explorer 16 Development Board to the MPLAB REAL ICE in-circuit emulator using an RJ-11 cable, and connect the MPLAB REAL ICE in-circuit emulator to the PC using a USB cable.
6. Connect a 9V power supply to the Explorer 16 Development Board.

## 3.3 SOFTWARE SETUP

To program the demonstration application into the dsPIC33FJ12GP202 device and set up the required software tools, perform the following steps:

1. Open the `demo\Thermal Interface Demo\Thermal_Demo.mcw` workspace in MPLAB IDE.
2. Select Project>Build All to compile and link the demonstration application program. Make sure the code compiles and links with no errors.
3. If the MPLAB REAL ICE in-circuit emulator is not enabled, enable it by selecting Debugger>MPLAB REAL ICE. Make sure the PC connects to the MPLAB REAL ICE in-circuit emulator and the dsPIC33FJ12GP202 device is detected.
4. If the DMCI window is not open, open it by selecting Tools>Data Monitor and Control Interface. The window should open with the Data Capture: LinearOut graph highlighted in the Dynamic Data View tab (and the corresponding box checked), as shown in Figure 3-2.

If you do not see this graph, click the Load Profile button at the bottom of the DMCI window, browse to the `demo\Thermal Interface Demo` folder, and open the `Thermal_Demo.dmci` file. This will load the characteristics and data setup and format information for the graph.

FIGURE 3-2: DMCI DYNAMIC DATA VIEW

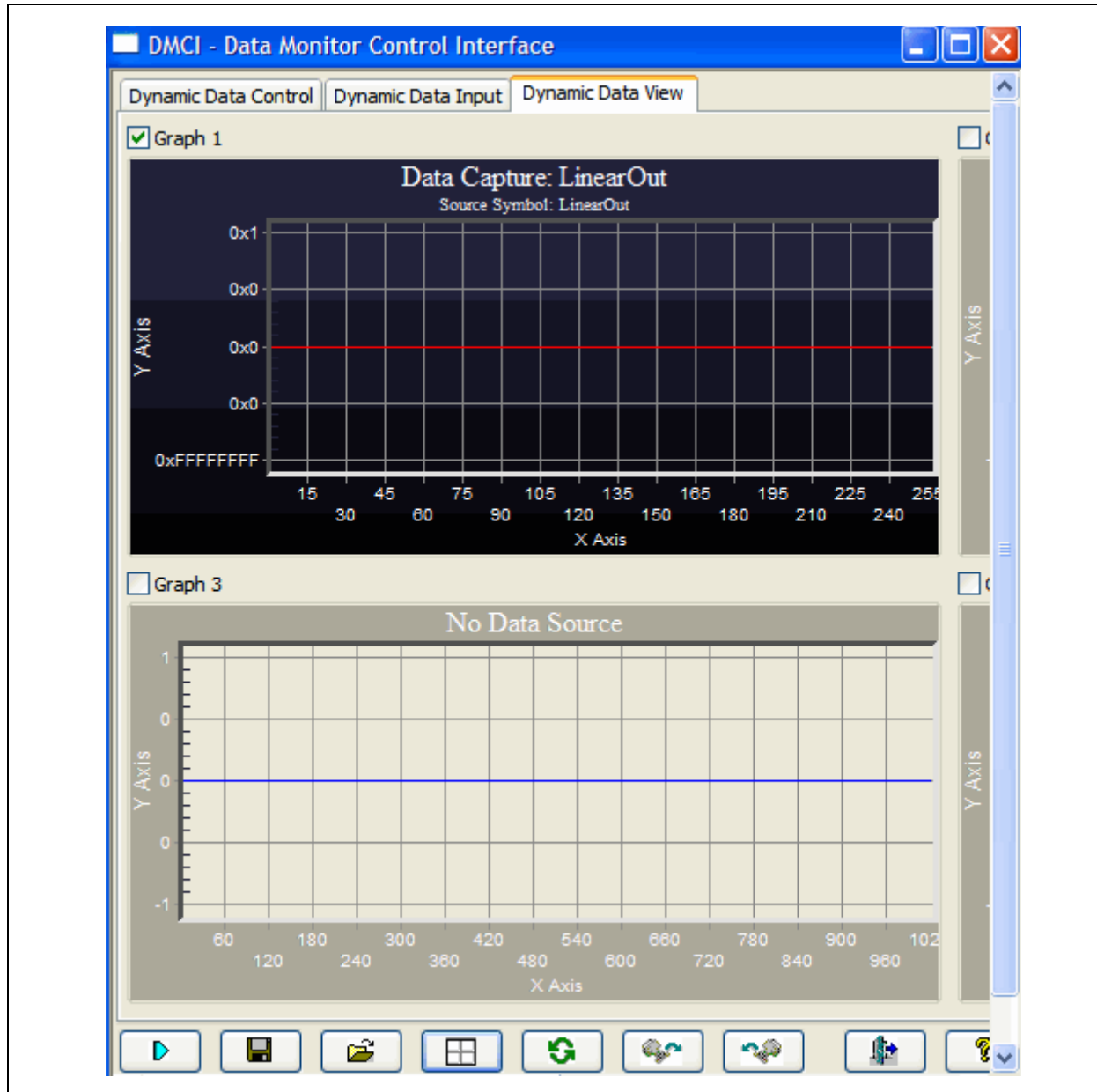

5. If the Watch window is not open, open it by selecting *View>Watch*. You should see the Temperature and LinearOut variables displayed with the blue and brown diamonds visible in the Update column, as shown in Figure 3-3. If either of the two diamonds is dimmed, you will need to right click and enable Runtime Watch and Runtime Capture for the LinearOut variable.



# Thermal Interface Demonstration

FIGURE 3-3: WATCH WINDOW CONFIGURATION

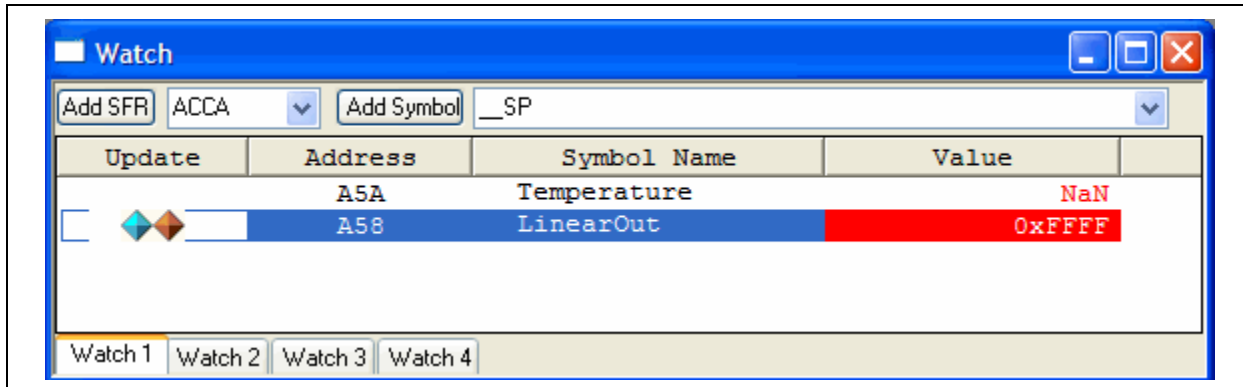

6. Select *Debugger>Program* to program the demonstration application into the dsPIC33FJ12GP202 device.

## 3.4 RUNNING THE DEMONSTRATION

To run the demonstration and observe the results, perform the following steps:

1. While in MPLAB IDE, select *Debugger>Reset* to reset MPLAB REAL ICE in-circuit emulator.
2. Select *Debugger>Run* to run the demonstration program.
3. Allow the program to run for a few seconds, and then halt program execution by selecting *Debugger>Halt*.
4. You should see the temperature value displayed in the Watch window variable `Temperature`. Note that a temperature close to 25 degrees Celsius is displayed if the thermocouple junction is kept at room temperature.
5. If you see a significantly smaller or larger temperature value displayed, adjust the R38 potentiometer screw using a small screwdriver and repeat steps 1-4 until you see a temperature close to room temperature (i.e., 25°C).
6. Repeat steps 1-3, but this time with the thermocouple junction either dipped in a hot liquid, touching a warm surface, or simply held tightly between your fingers. As long as the program is running, you should see the `LinearOut` variable value in the Watch window continuously increasing and decreasing with temperature. You should also see the corresponding graph in the DMCI window rising and falling with temperature. On halting the program execution, you should see the current temperature displayed in the Watch window.

# Thermal/Linear Intelligent Sensor PICtail™ Plus Daughter Board

---

---

NOTES:

## Chapter 4. Linear Interface Demonstration

This chapter describes a simple program that demonstrates how to use the Daughter Board to capture and process signals from any generic linear sensor through the linear sensor interface.

### 4.1 DEMONSTRATION OVERVIEW

The CD that accompanies the Daughter Board contains a linear interface demonstration application. All files pertaining to this demonstration are located in the following folder on the CD: `demo\Linear Interface Demo`.

As shown in Figure 4-1, this sample application uses the Daughter Board to perform signal conditioning on an incoming 3200 Hz sinusoidal signal, and uses the on-chip ADC of the dsPIC33FJ12GP202 device to convert the signal to a digital form. A 1700 Hz noise source is artificially added to the sampled signal in software, thereby modeling the effect of narrowband noise on a sampled sensor signal.

In addition, the application software uses the DSP features of the dsPIC33F architecture to filter out the 1700 Hz narrowband noise using a highly selective notch filter. The filtering is performed using the Finite Impulse Response (FIR) filtering function from the DSP library, which is included with the MPLAB C30 compiler.

The noise-corrupted input signal (filter input) and the noise-free output signal (filter output) are plotted on the Data Monitor and Control Interface (DMCI) using the MPLAB REAL ICE in-circuit emulator.

**FIGURE 4-1: LINEAR INTERFACE DEMONSTRATION**

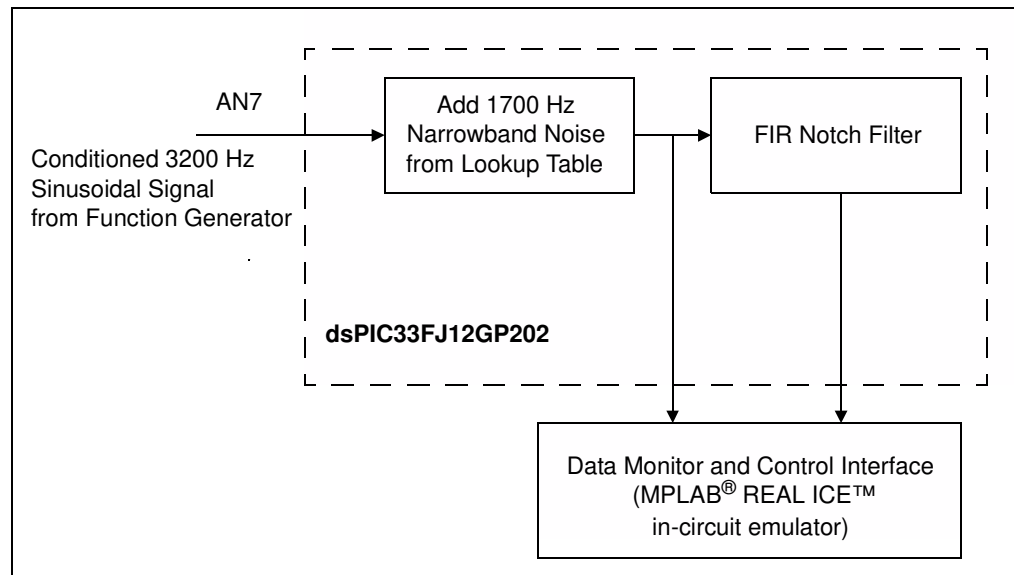

The demonstration program consists of the following basic software elements:

- ADC Driver
- Notch Filter

## 4.1.1 ADC Driver

The ADC driver reads the incoming signals from the linear interface (after signal conditioning by the level shifter and anti-aliasing filter), on the 12-bit ADC channel AN7. The source code file, `adcDrv1.c`, contains the ADC initialization function `initAdc1()` as well as the ADC ISR.

Noise samples from the constant table `NoiseSamples` are added to successive input samples, and the composite sample is then stored in a variable named `SignalNoiseIn`.

## 4.1.2 Notch Filter

The `Notch.s` file contains the coefficients and other parameters of a 63-tap FIR filter designed using the dsPIC DSC Filter Design tool. This filter has been designed to suppress narrowband (single-tone) noise at 1700 Hz while not attenuating the desired 3200 Hz signal. The filtered output sample is stored in a variable named `SignalOut`.

The actual filtering operation is performed using a pre-compiled function named `FIR()` from the DSP library in the MPLAB C30 compiler. The DMCI utility in MPLAB REAL ICE in-circuit emulator can be used to observe the filter input and output samples during run time.

## 4.2 DEMONSTRATION HARDWARE SETUP

To use this demonstration, you will need the following hardware:

- Thermal/Linear Intelligent Sensor PICtail Plus Daughter Board
- Explorer 16 Development Board
- dsPIC33FJ12GP202 Plug-In Module (MA330015)
- PC running the following software:
  - MPLAB IDE software, version 8.10 or higher
  - MPLAB C30 compiler, version 3.01 or higher
- MPLAB REAL ICE in-circuit emulator
- Any signal source such as a function generator that can generate a bipolar sinusoidal signal with its mid-point at 0V. For example, a Model 3001 Portable Audio Generator from BK Precision was used for testing the linear interface. The signal should be sufficiently attenuated (e.g., -20 dB) so as not to cause signal clipping or saturation.

Before programming or running the demonstration application, make the following hardware connections:

1. Connect the signal from the function generator (or other signal source) between the positive and negative test points on the Linear Signal Connector J3 of the Daughter Board.
2. Set up the function generator to generate a 3200 Hz sinusoidal signal. Adjust the amplitude as needed.
3. On the Daughter Board, make sure the JP2 jumper is set to the 1-2 position (i.e., include the level shifter circuit in the signal path). Pin 1 of the jumper is indicated by an arrow adjacent to the pin.
4. Insert the Daughter Board into the J5 socket of the Explorer 16 Development Board.
5. On the Explorer 16 Development Board, insert a dsPIC33FJ12GP202 PIM.
6. On the Explorer 16 Development Board, make sure the switch S2 is set to the PIM position and the jumper J7 is set to the PIC24 position.
7. Connect the Explorer 16 Development Board to the MPLAB REAL ICE in-circuit emulator using an RJ-11 cable, and connect the MPLAB REAL ICE in-circuit emulator to the PC using a USB cable.
8. Connect a 9V power supply to the Explorer 16 Development Board.

## 4.3 DEMONSTRATION SOFTWARE SETUP

To program the demonstration application into the dsPIC33FJ12GP202 device and set up the required software tools, perform the following steps:

1. Open the `demo\Linear Interface Demo\Linear_Demo.mcw` workspace in MPLAB IDE.
2. Select *Project>Build All* to compile and link the demonstration application program. Make sure the code compiles and links with no errors.
3. If the MPLAB REAL ICE in-circuit emulator is not enabled, enable it by selecting *Debugger>MPLAB REAL ICE*. Make sure the PC connects to the MPLAB REAL ICE in-circuit emulator and that the dsPIC33FJ12GP202 device is detected.
4. If the DMCI window is not open, open it by selecting *Tools>Data Monitor and Control Interface*. This should open the DMCI window with the Data Capture: SignalNoiseIn and Data Capture: SignalOut graphs highlighted (and the corresponding boxes checked) in the Dynamic Data View tab.

If you do not see this graph, click the Load Profile button at the bottom of the DMCI window, browse to the `demo\Linear Interface Demo` folder, and open the `Linear_Demo.dmci` file. This will load the characteristics and data setup and format information for the graph.

5. If the Watch window is not open, open it by selecting *View>Watch*. You should see the `SignalNoiseIn` and `SignalOut` variables displayed with the corresponding blue diamonds visible in the Update column, as shown in Figure 4-2. If either of the two blue diamonds is dimmed, you will need to right click and enable Runtime Capture for that particular variable.

FIGURE 4-2: WATCH WINDOW CONFIGURATION

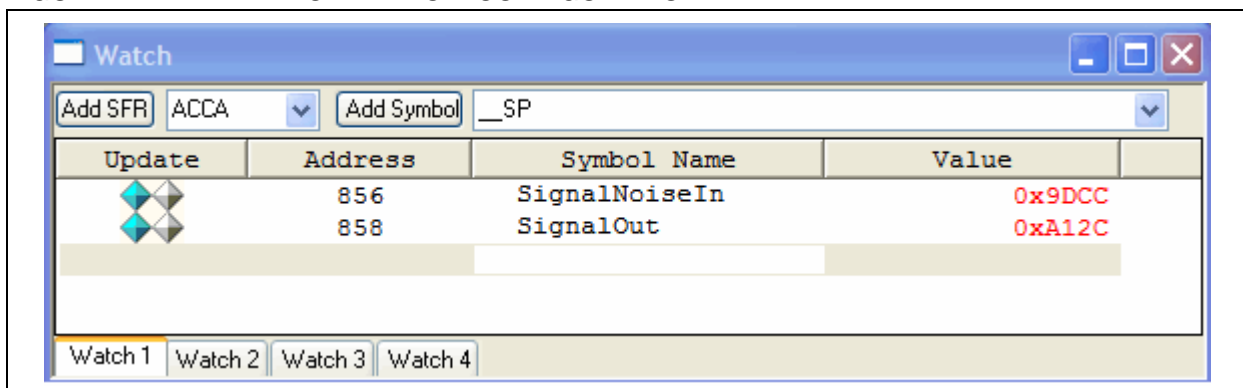

6. Select *Debugger>Program* to program the demonstration application into the dsPIC33FJ12GP202 device.

## 4.4 RUNNING THE DEMONSTRATION

To operate the demonstration and observe the results, perform the following steps:

1. While in MPLAB IDE, select *Debugger>Reset* to reset MPLAB REAL ICE in-circuit emulator.
2. Select *Debugger>Run* to run the demonstration program.
3. Allow the program to run for a few seconds, and then halt program execution by selecting *Debugger>Halt*.

You should see the input and output signal sample values plotted on the two graphs in the DMCI window. The plotting will stop after the DMCI's internal 8000-sample data buffer becomes full. However, due to the large number of data points, the graph is not easy to analyze at this point. Therefore, the number of data points needs to be reduced using steps 4 through 6.

4. Right click the SignalNoiseIn plot in the DMCI window and select *Extended Functions>Customization*, as shown in Figure 4-3.

FIGURE 4-3: DMCI EXTENDED FUNCTIONS

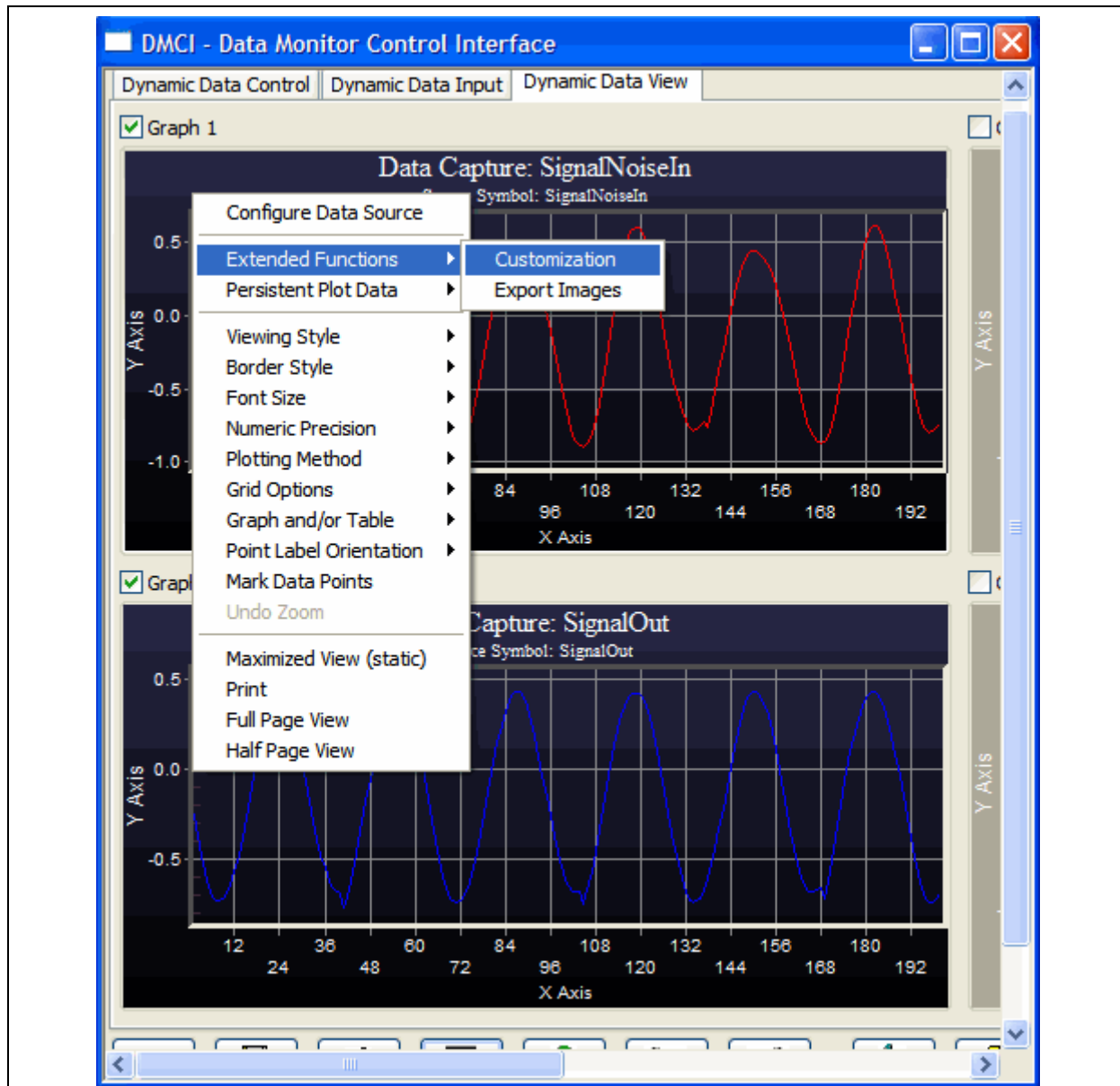

# Linear Interface Demonstration

5. In the Customization dialog box, choose the Selected radio button. Then, from the list of data points, select the first 200 points as shown in Figure 4-4.

**FIGURE 4-4: DMCI DATA CAPTURE CUSTOMIZATION**

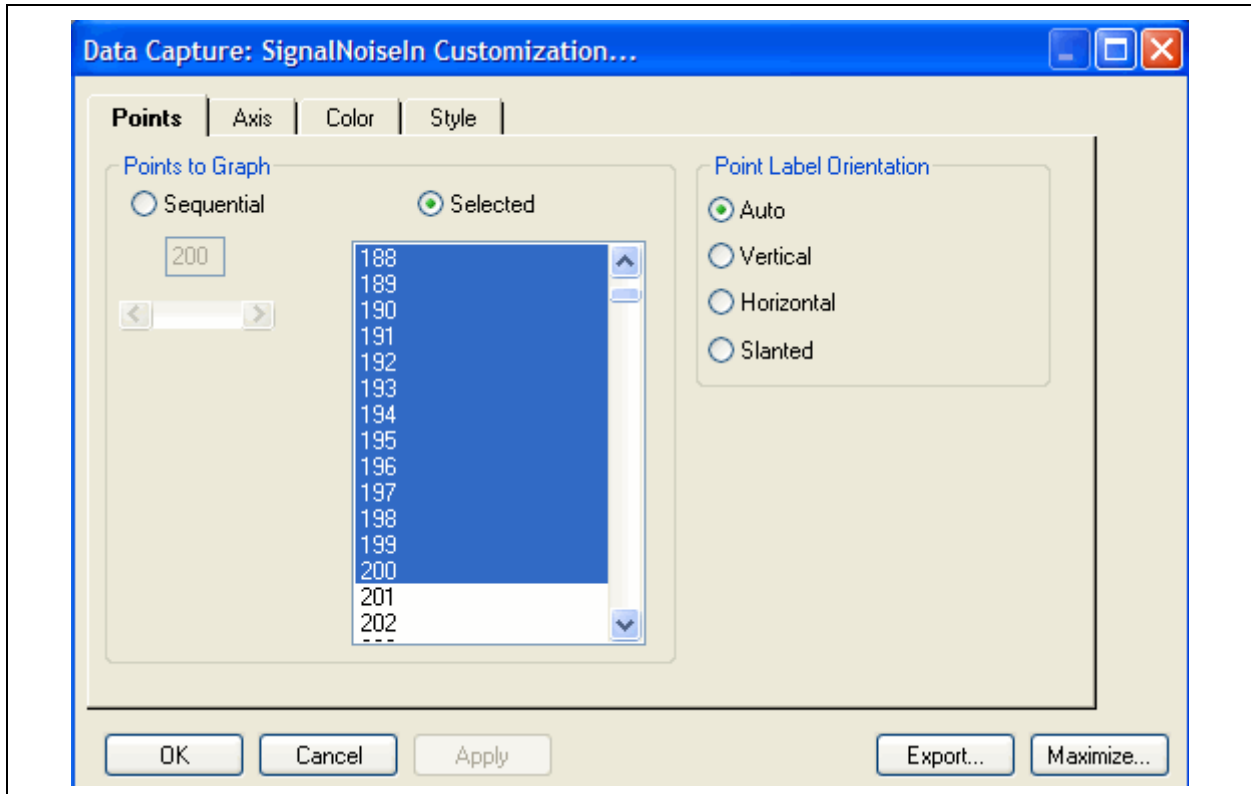

6. Repeat steps 4 and 5 for the SignalOut graph.

Now that only 200 signal samples are displayed on the plots, it should be apparent that the SignalNoiseIn signal is a combination of two sinusoidal frequency components as expected: the incoming 3200 Hz signal and the 1700 Hz noise added in software. The SignalOut signal should resemble a relatively pure 3200 Hz sinusoidal signal. The expected appearance of the graphs is shown in Figure 4-5.

FIGURE 4-5: FILTER INPUT AND OUTPUT SIGNALS



7. If the signal mid-point (DC level) has a significant offset from 0V, adjust the R30 potentiometer screw using a small screwdriver and repeat steps 1 through 6 until you see a well-shaped pair of graphs, as shown in Figure 4-4. If the SignalNoiseIn looks like a single 1700 Hz sinusoidal signal, check your function generator output and increase its amplitude as needed. Otherwise, if the signals look clipped or saturated, decrease the signal amplitude on your function generator.



**Appendix A. Schematics and Layout**

This appendix contains the layout and schematics for the Thermal/Linear Intelligent Sensor PICtail™ Plus Daughter Board.

**FIGURE A-1: THERMAL/LINEAR INTELLIGENT SENSOR PICtail™ PLUS DAUGHTER BOARD LAYOUT**

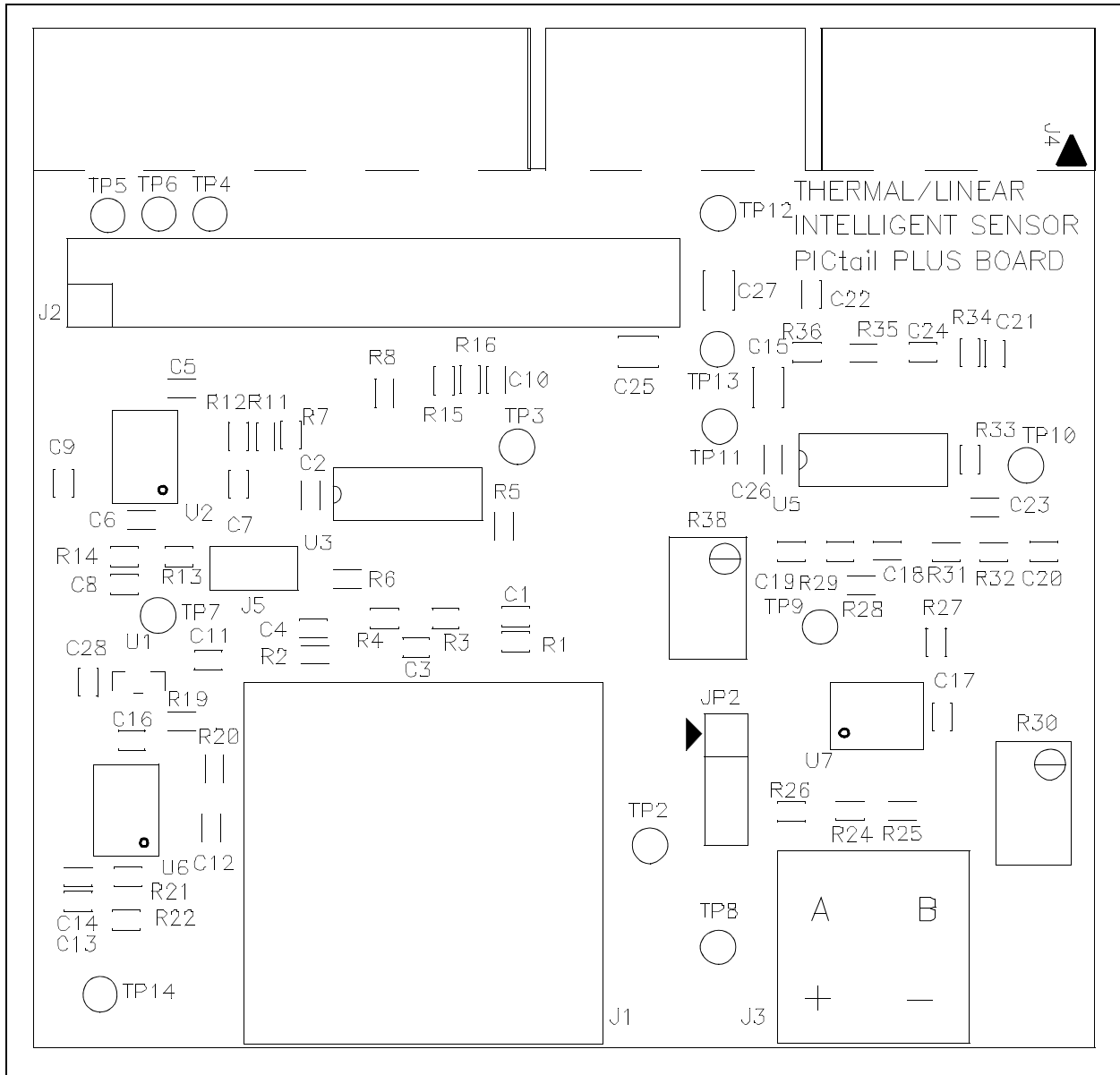

# Thermal/Linear Intelligent Sensor PICtail™ Plus Daughter Board

FIGURE A-2: THERMAL/LINEAR INTELLIGENT SENSOR PICtail™ PLUS DAUGHTER BOARD SCHEMATIC (SHEET 1 OF 3)

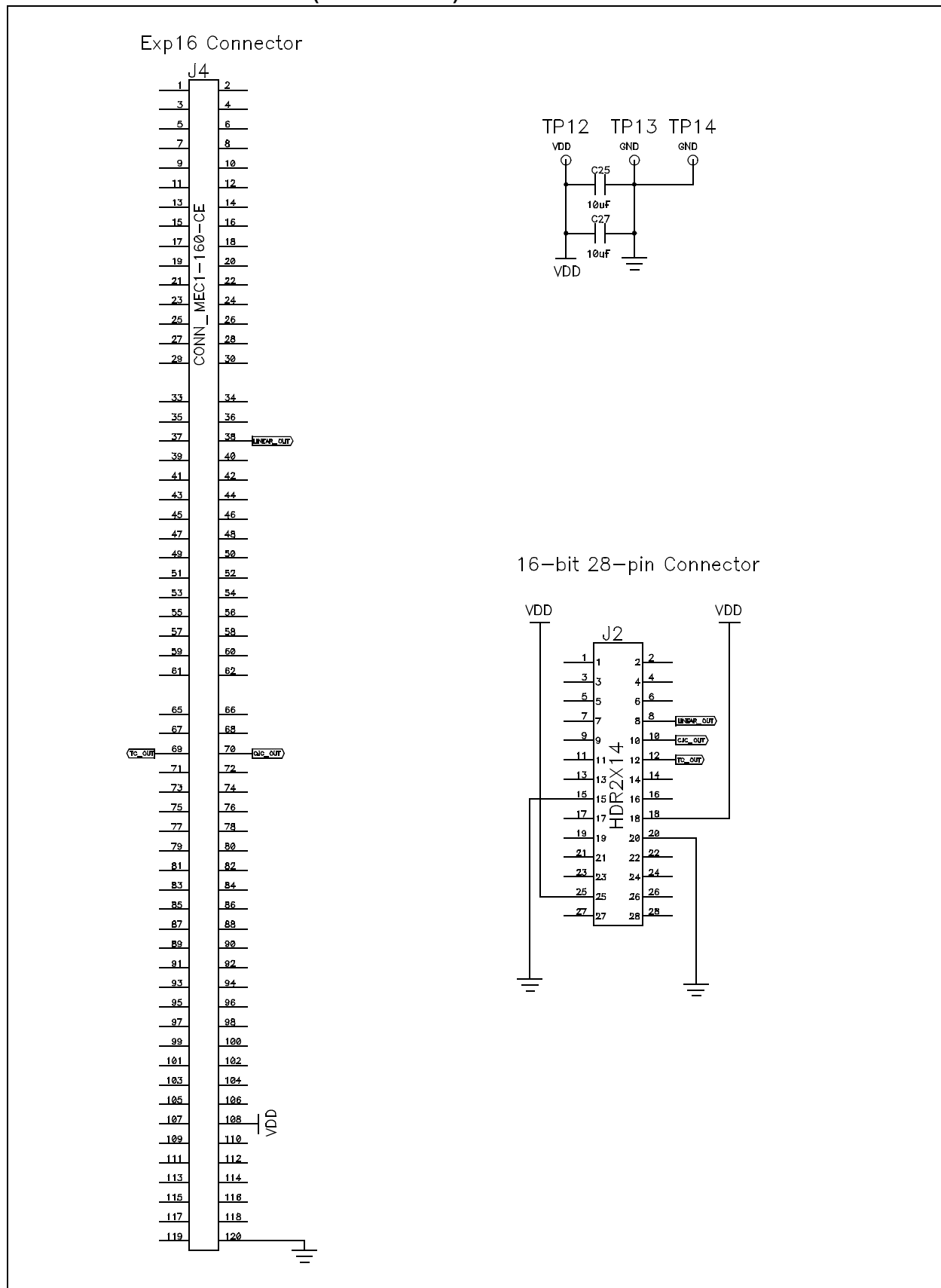

FIGURE A-3: THERMAL/LINEAR INTELLIGENT SENSOR PICTAIL™ PLUS DAUGHTER BOARD SCHEMATIC (SHEET 2 OF 3)

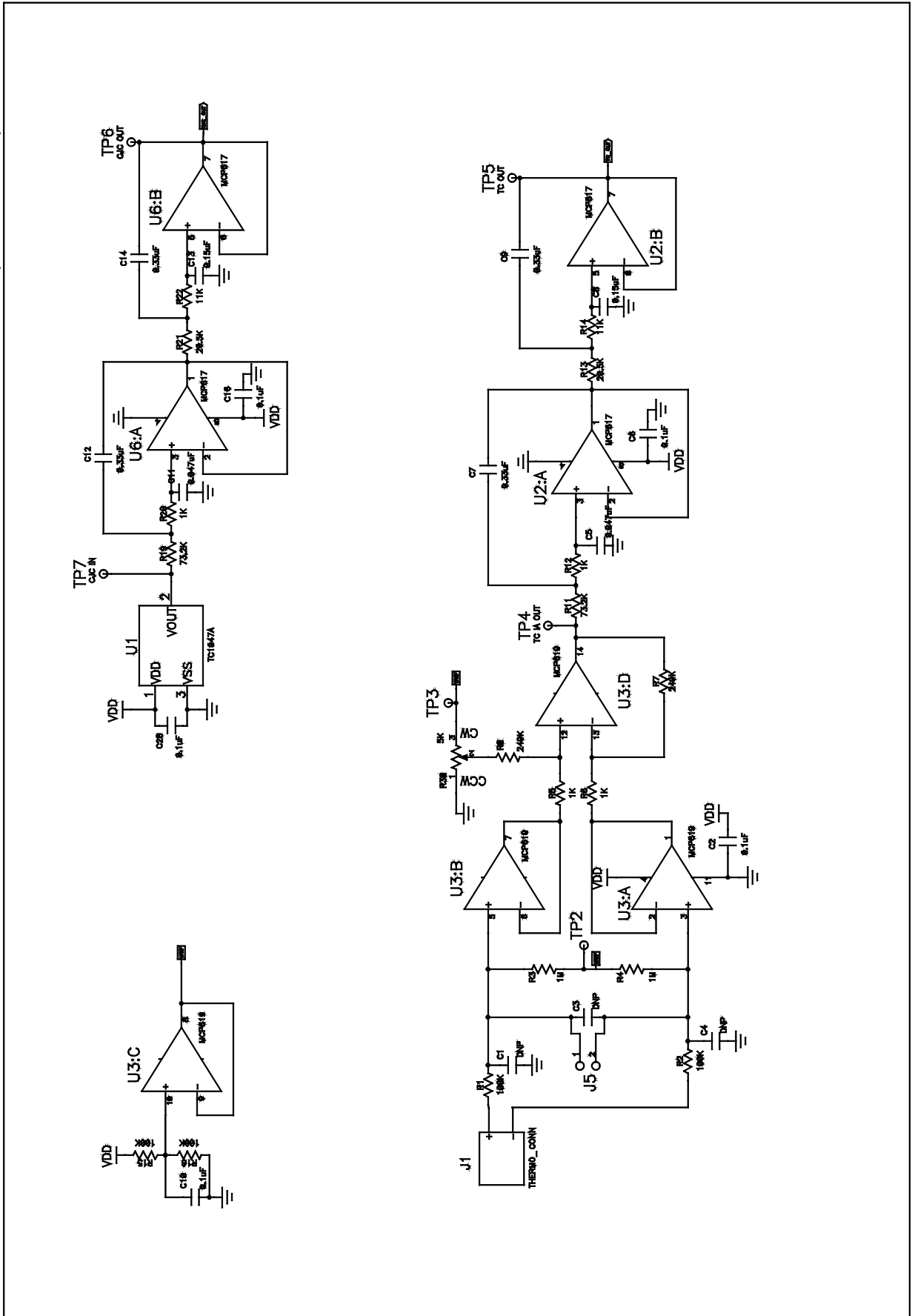
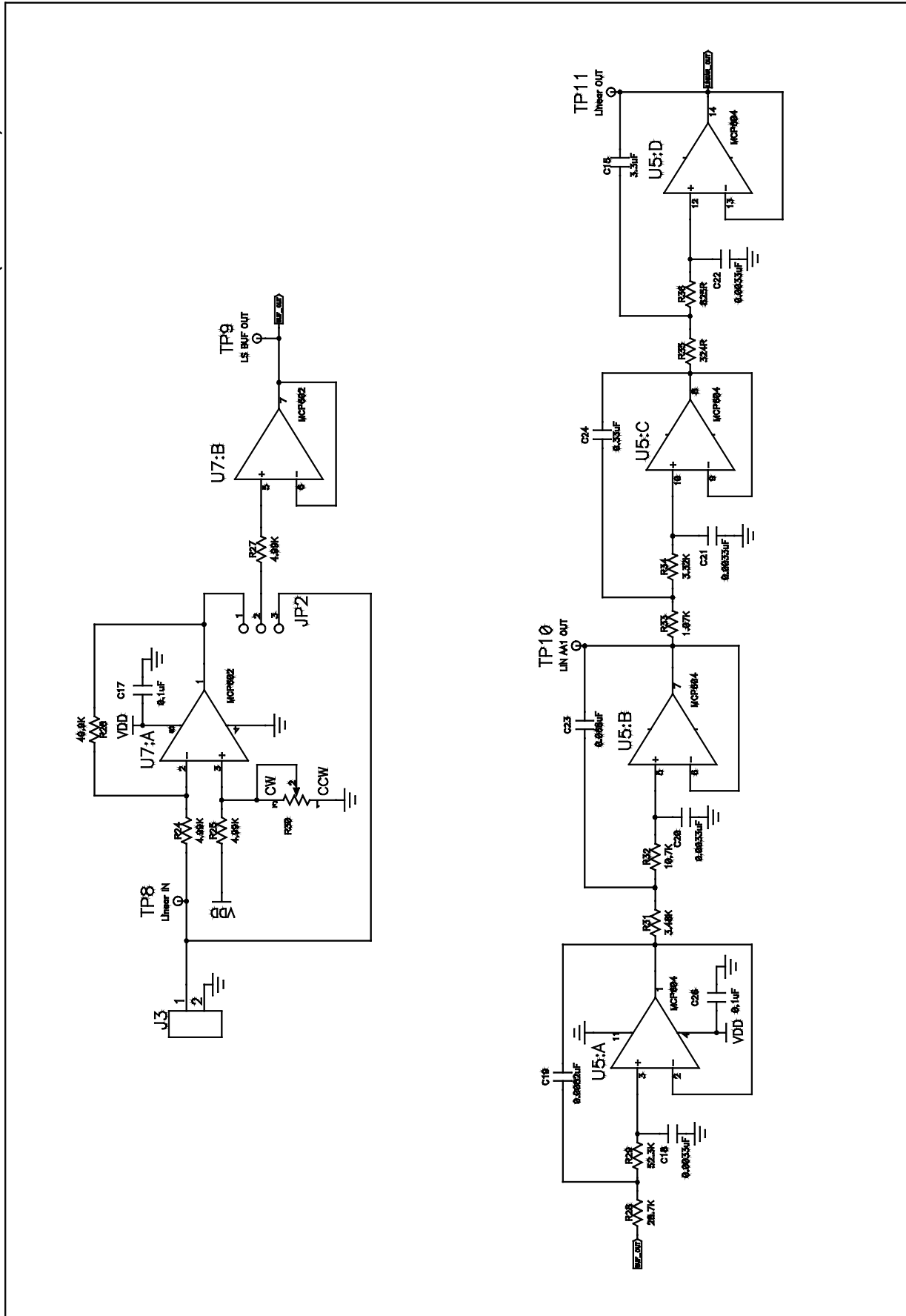

FIGURE A-4: THERMAL/LINEAR INTELLIGENT SENSOR PICtail™ PLUS DAUGHTER BOARD SCHEMATIC (SHEET 3 OF 3)





# THERMAL/LINEAR INTELLIGENT SENSOR PICtail™ PLUS DAUGHTER BOARD

## Index

<b>A</b>		<b>L</b>	
ADC Driver .....	18, 24	Level Shifter Operation .....	16
Averaging and Cold Junction Compensation Function .....	18	Linear Interface Demonstration .....	23
<b>C</b>		DMCI Data Capture Customization .....	27
Customer Notification Service .....	5	DMCI Extended Functions .....	26
Customer Support .....	6	Filter Input and Output Signals .....	28
<b>D</b>		Hardware Setup .....	24
Documentation		Running The Demonstration .....	26
Conventions .....	3	Software Setup .....	25
Layout .....	1	Watch Window Configuration .....	25
<b>H</b>		Linear Sensor Signal Conditioning .....	16
Hardware Components		Linearization .....	18
16-bit 28-pin Starter Development Board		<b>M</b>	
Connector (J2) .....	13	Microchip Internet Web Site .....	5
Anti-Aliasing Low-Pass Filter for		<b>N</b>	
Linear Signal (U5) .....	13	Notch Filter .....	24
Anti-Aliasing Low-Pass Filter for		<b>R</b>	
Temperature Sensor IC Signal (U6) ...	13	Reading, Recommended .....	4
Anti-Aliasing Low-Pass Filter for		<b>S</b>	
Thermocouple Signal (U2) .....	13	Schematics	
Differential Amplifier for Thermocouple		Sheet 1 of 3 .....	30
Signal (U3) .....	13	Sheet 2 of 3 .....	31
Explorer 16 PICtail Plus Connector (J4) .....	13	Sheet 3 of 3 .....	32
Jumper for Offset Calibration of Differential		<b>T</b>	
Amplifier (J5) .....	13	Temperature Sensor IC Signal Conditioning .....	15
Jumper to Include or Bypass Level		Thermal Interface Demonstration .....	17
Shifter (JP2) .....	14	DMCI Dynamic Data View .....	20
Level Shifter for Linear Signal (U7) .....	14	Hardware Setup .....	19
Linear Signal Connector (J3) .....	14	Running the Demonstration .....	21
Potentiometer for Differential Amplifier		Software Setup .....	19
Output Offset Adjustment (R38) .....	13	Watch Window Configuration .....	21
Potentiometer for Level Shifter		Thermal/Linear Intelligent Sensor PICtail	
Adjustment (R30) .....	14	Plus Daughter Board .....	8
Thermocouple Connector (J1) .....	14	Block Diagram .....	15
<b>I</b>		Board Layout .....	29
Internet Address .....	5	Hardware Components .....	12
<b>K</b>		Setup .....	9
K-type Thermocouple Polynomial .....	18	Thermocouple Signal Conditioning .....	15
		<b>W</b>	
		Warranty Registration .....	4
		WWW Address .....	5



---

---

## Worldwide Sales and Service

---

---

### AMERICAS

**Corporate Office**  
2355 West Chandler Blvd.  
Chandler, AZ 85224-6199  
Tel: 480-792-7200  
Fax: 480-792-7277  
Technical Support:  
<http://support.microchip.com>  
Web Address:  
[www.microchip.com](http://www.microchip.com)

**Atlanta**  
Duluth, GA  
Tel: 678-957-9614  
Fax: 678-957-1455

**Boston**  
Westborough, MA  
Tel: 774-760-0087  
Fax: 774-760-0088

**Chicago**  
Itasca, IL  
Tel: 630-285-0071  
Fax: 630-285-0075

**Dallas**  
Addison, TX  
Tel: 972-818-7423  
Fax: 972-818-2924

**Detroit**  
Farmington Hills, MI  
Tel: 248-538-2250  
Fax: 248-538-2260

**Kokomo**  
Kokomo, IN  
Tel: 765-864-8360  
Fax: 765-864-8387

**Los Angeles**  
Mission Viejo, CA  
Tel: 949-462-9523  
Fax: 949-462-9608

**Santa Clara**  
Santa Clara, CA  
Tel: 408-961-6444  
Fax: 408-961-6445

**Toronto**  
Mississauga, Ontario,  
Canada  
Tel: 905-673-0699  
Fax: 905-673-6509

### ASIA/PACIFIC

**Asia Pacific Office**  
Suites 3707-14, 37th Floor  
Tower 6, The Gateway  
Harbour City, Kowloon  
Hong Kong  
Tel: 852-2401-1200  
Fax: 852-2401-3431

**Australia - Sydney**  
Tel: 61-2-9868-6733  
Fax: 61-2-9868-6755

**China - Beijing**  
Tel: 86-10-8528-2100  
Fax: 86-10-8528-2104

**China - Chengdu**  
Tel: 86-28-8665-5511  
Fax: 86-28-8665-7889

**China - Hong Kong SAR**  
Tel: 852-2401-1200  
Fax: 852-2401-3431

**China - Nanjing**  
Tel: 86-25-8473-2460  
Fax: 86-25-8473-2470

**China - Qingdao**  
Tel: 86-532-8502-7355  
Fax: 86-532-8502-7205

**China - Shanghai**  
Tel: 86-21-5407-5533  
Fax: 86-21-5407-5066

**China - Shenyang**  
Tel: 86-24-2334-2829  
Fax: 86-24-2334-2393

**China - Shenzhen**  
Tel: 86-755-8203-2660  
Fax: 86-755-8203-1760

**China - Wuhan**  
Tel: 86-27-5980-5300  
Fax: 86-27-5980-5118

**China - Xiamen**  
Tel: 86-592-2388138  
Fax: 86-592-2388130

**China - Xian**  
Tel: 86-29-8833-7252  
Fax: 86-29-8833-7256

**China - Zhuhai**  
Tel: 86-756-3210040  
Fax: 86-756-3210049

### ASIA/PACIFIC

**India - Bangalore**  
Tel: 91-80-4182-8400  
Fax: 91-80-4182-8422

**India - New Delhi**  
Tel: 91-11-4160-8631  
Fax: 91-11-4160-8632

**India - Pune**  
Tel: 91-20-2566-1512  
Fax: 91-20-2566-1513

**Japan - Yokohama**  
Tel: 81-45-471- 6166  
Fax: 81-45-471-6122

**Korea - Daegu**  
Tel: 82-53-744-4301  
Fax: 82-53-744-4302

**Korea - Seoul**  
Tel: 82-2-554-7200  
Fax: 82-2-558-5932 or  
82-2-558-5934

**Malaysia - Kuala Lumpur**  
Tel: 60-3-6201-9857  
Fax: 60-3-6201-9859

**Malaysia - Penang**  
Tel: 60-4-227-8870  
Fax: 60-4-227-4068

**Philippines - Manila**  
Tel: 63-2-634-9065  
Fax: 63-2-634-9069

**Singapore**  
Tel: 65-6334-8870  
Fax: 65-6334-8850

**Taiwan - Hsin Chu**  
Tel: 886-3-572-9526  
Fax: 886-3-572-6459

**Taiwan - Kaohsiung**  
Tel: 886-7-536-4818  
Fax: 886-7-536-4803

**Taiwan - Taipei**  
Tel: 886-2-2500-6610  
Fax: 886-2-2508-0102

**Thailand - Bangkok**  
Tel: 66-2-694-1351  
Fax: 66-2-694-1350

### EUROPE

**Austria - Wels**  
Tel: 43-7242-2244-39  
Fax: 43-7242-2244-393

**Denmark - Copenhagen**  
Tel: 45-4450-2828  
Fax: 45-4485-2829

**France - Paris**  
Tel: 33-1-69-53-63-20  
Fax: 33-1-69-30-90-79

**Germany - Munich**  
Tel: 49-89-627-144-0  
Fax: 49-89-627-144-44

**Italy - Milan**  
Tel: 39-0331-742611  
Fax: 39-0331-466781

**Netherlands - Drunen**  
Tel: 31-416-690399  
Fax: 31-416-690340

**Spain - Madrid**  
Tel: 34-91-708-08-90  
Fax: 34-91-708-08-91

**UK - Wokingham**  
Tel: 44-118-921-5869  
Fax: 44-118-921-5820