



Intel® Wireless Flash Memory (W18/W30 SCSP)

32WQ and 64WQ Family with Asynchronous RAM

Datasheet

Product Features

- **Device Architecture**
 - Flash Density: 32-Mbit, 64-Mbit
 - Async PSRAM Density: 8-, 16-, 32-Mbit
 - Async SRAM Density: 4-, 8-, 16-Mbit
 - Top, Bottom or Dual flash parameter configuration
- **Device Voltage**
 - Flash $V_{CC} = 1.8$ V (90 nm or 130 nm)
 - Flash $V_{CCQ} = 1.8$ V (90 nm)
 - Flash $V_{CCQ} = 1.8$ V or 3.0 V (130 nm)
 - RAM $V_{CC} = 3.0$ V
 - RAM $V_{CCQ} = 1.8$ V or 3.0 V
- **Device Packaging**
 - 88 balls (8 x 10 active ball matrix)
 - Area: 8x10 mm
 - Height: 1.2 mm to 1.4 mm
- **PSRAM Performance**
 - 88 ns initial access, 30 ns async page reads at 1.8 V I/O
 - 70 ns initial access, 25 ns async page reads at 1.8 V I/O
 - 85 ns initial access, 35 ns async page reads at 3.0 V I/O
 - 70 ns initial access, 25 ns async page reads at 3.0 V I/O
- **SRAM Performance**
 - 70 ns initial access at 1.8 V or 3.0 V I/O
- **Flash Performance**
 - 65 ns initial access at 1.8 V I/O
 - 70 ns initial access at 3.0 V I/O
 - 25 ns async page at 1.8 V or 3.0 V I/O
 - 14 ns sync reads (t_{CHQV}) at 1.8 V I/O
 - 20 ns sync reads (t_{CHQV}) at 3.0 V I/O
 - Enhanced Factory Programming: 3.10 μ s/Word (Typ)
- **Flash Architecture**
 - Read-While-Write/Erase
 - Asymmetrical blocking structure
 - 4-KWord parameter blocks (Top or Bottom)
 - 32-KWord main blocks
 - 4-Mbit partition size
 - 128-bit One-Time Programmable (OTP) Protection Register
 - Zero-latency block locking
 - Absolute write protection with block lock using F-VPP and F-WP#
- **Flash Software**
 - Intel® Flash Data Integrator (FDI)
 - Common Flash Interface (CFI)
- **Quality and Reliability**
 - Extended Temperature: -25 °C to $+85$ °C
 - Minimum 100K flash block erase cycle
 - 90 nm ETOX™ IX flash technology
 - 130 nm ETOX™ VIII flash technology

The Intel® Wireless Flash Memory (W18/W30 SCSP) family offers a variety of flash plus static RAM combinations in a common package footprint. The flash memory features 1.8 V low-power operations with flexible, multi-partition, dual-operation Read-While-Write / Read-While-Erase, asynchronous, and synchronous reads. This SCSP device integrates up to two flash die, one PSRAM die, and one SRAM die in a low-profile package compatible with other SCSP families with QUAD+ ballout.



INFORMATION IN THIS DOCUMENT IS PROVIDED IN CONNECTION WITH INTEL® PRODUCTS. EXCEPT AS PROVIDED IN INTEL'S TERMS AND CONDITIONS OF SALE FOR SUCH PRODUCTS, INTEL ASSUMES NO LIABILITY WHATSOEVER, AND INTEL DISCLAIMS ANY EXPRESS OR IMPLIED WARRANTY RELATING TO SALE AND/OR USE OF INTEL PRODUCTS, INCLUDING LIABILITY OR WARRANTIES RELATING TO FITNESS FOR A PARTICULAR PURPOSE, MERCHANTABILITY, OR INFRINGEMENT OF ANY PATENT, COPYRIGHT, OR OTHER INTELLECTUAL PROPERTY RIGHT.

Intel Corporation may have patents or pending patent applications, trademarks, copyrights, or other intellectual property rights that relate to the presented subject matter. The furnishing of documents and other materials and information does not provide any license, express or implied, by estoppel or otherwise, to any such patents, trademarks, copyrights, or other intellectual property rights.

Intel products are not intended for use in medical, life saving, life sustaining, critical control or safety systems, or in nuclear facility applications.

Intel may make changes to specifications and product descriptions at any time, without notice.

Contact your local Intel sales office or your distributor to obtain the latest specifications and before placing your product order.

Copies of documents which have an ordering number and are referenced in this document, or other Intel literature may be obtained by calling 1-800-548-4725 or by visiting Intel's website at <http://www.intel.com>.

*Other names and brands may be claimed as the property of others.

Copyright © 2005, Intel Corporation

Contents

1.0	Introduction	6
1.1	Nomenclature	6
1.2	Conventions.....	6
2.0	Functional Overview	8
2.1	Block Diagram	8
2.2	Flash Memory Map and Partitioning	9
3.0	Package Information	11
4.0	Ballout and Signal Description	13
4.1	Signal Ballout.....	13
4.2	Signal Descriptions	14
5.0	Maximum Ratings and Operating Conditions	16
5.1	Absolute Maximum Ratings	16
5.2	Operating Conditions	17
5.3	Capacitance.....	17
6.0	Electrical Specifications	18
6.1	DC Characteristics.....	18
7.0	AC Characteristics	21
7.1	Flash AC Characteristics	21
7.2	SRAM AC Characteristics.....	21
7.3	PSRAM AC Characteristics	23
7.4	Device AC Test Conditions.....	28
8.0	Flash Power Consumption	29
9.0	Device Operation	30
9.1	Bus Operations	30
9.2	Flash Command Definitions.....	33
10.0	Flash Read Operations	34
11.0	Flash Program Operations	35
12.0	Flash Erase Operations	36
13.0	Flash Security Modes	37
14.0	Flash Read Configuration Register	38
15.0	SRAM Operations	39
15.1	Power-up Sequence and Initialization	39
15.2	Data Retention Mode.....	39
16.0	PSRAM Operations	41



16.1	Power-Up Sequence and Initialization.....	41
16.2	Standby Mode/ Deep Power-Down Mode	42
16.3	PSRAM Special Read and Write Constraints	43
Appendix A	Write State Machine.....	45
Appendix B	Common Flash Interface	46
Appendix C	Flash Flowcharts	47
Appendix D	Additional Information	48
Appendix E	Ordering Information.....	49

Revision History

Date	Revision	Description
June 2003	-001	Initial release.
September 2003	-002	Changed PSRAM Read values. Added new Transient Equivalent Testing Load Circuit figure. General text edits.
May 2004	-006	Reformatted the datasheet and moved sections around according to the new layout.
August 2004	-007	Added 90 nm product information. Added line items to Table 1 "32WQ and 64WQ W18/W30 SCSP Ordering Information (Flash Only)" on page 50 . Added DC and AC specs for the new line items and edits to related sections.
January 2005	-008	Added line items to Table 1 "32WQ and 64WQ W18/W30 SCSP Ordering Information (Flash Only)" on page 50 Added 32WQ product information.
June 2005	-009	Added line items to Table 1 "32WQ and 64WQ W18/W30 SCSP Ordering Information (Flash Only)" on page 50

1.0 Introduction

This document contains information pertaining to the products in the Intel® Wireless Flash Memory (W18/W30 SCSP) family with asynchronous RAM. The W18/W30 SCSP 32WQ and 64WQ families offer a wide variety of stacked combinations that include single flash die, two flash die, flash + PSRAM, and flash + SRAM options. This document provides information where this SCSP family differs from the Intel® Wireless Flash Memory (W18/W30) discrete device.

Refer to the discrete datasheets *Intel® Wireless Flash Memory (W18) Datasheet* (order number 290701) and *Intel® Wireless Flash Memory (W30) Datasheet* (order number 290702) for flash product details not included in this SCSP datasheet.

1.1 Nomenclature

0x	Hexadecimal prefix
0b	Binary prefix
Byte	8 bits
CFI	Common Flash Interface
CUI	Command User Interface
DU	Don't Use
ETOX	EPROM Tunnel Oxide
FDI	Flash Data Integrator (Intel® software solution)
k (noun)	1 thousand
Kb	1024 bits
KB	1024 bytes
Kword	1024 words
M (noun)	1 million
Mb	1,048,576 bits
MB	1,048,576 bytes
OTP	One-Time Programmable
PLR	Protection Lock Register
PR	Protection Register
PRD	Protection Register Data
RCR	Read Configuration Register
RFU	Reserved for Future Use
SCSP	Stacked Chip Scale Package
SR	Status Register
SRD	Status Register Data
Word	16 bits
WSM	Write State Machine

1.2 Conventions

Group Membership Brackets: Square brackets are used to designate group membership or to define a group of signals with a similar function, such as A[21:1] and SR[4,1].

VCC vs. V_{CC}: When referring to a signal or package-connection name, the notation used is VCC, etc. When referring to a timing or electrical level, the notation used is subscripted such as V_{CC}, etc.



Device: This term is used interchangeably throughout this document to denote either a particular die, or the combination of multiple die within a single package.

F[3:1]-CE#, F[2:1]-OE#: This is the method used to refer to more than one chip-enable or output enable at the same time. When each is referred to individually, the reference will be F1-CE# and F1-OE# (for die #1), and F2-CE# and F2-OE# (for die #2).

F-VCC, P-VCC or S-VCC: When referencing flash memory signals or timings, the notation used is F-VCC or F-V_{CC}, respectively. When the reference is to PSRAM signals or timings, the notation is prefixed with “P-” (e.g., P-VCC, P-V_{CC}). When referencing SRAM signals or timings, the notation is prefixed with “S-” (e.g., S-VCC or S-V_{CC}). P-VCC and S-VCC are RFU for stacked combinations that do not include PSRAM or SRAM.

R-OE#, R-LB#, R-UB#, R-WE#: These are used to identify RAM OE#, LB#, UB#, WE# signals, and are usually shared between 2 or more RAM die. R-OE#, R-LB#, R-UB# and R-WE are RFU for stacked combinations that do not include PSRAM or SRAM.

2.0 Functional Overview

This section provides an overview of the features and capabilities of the Intel® Wireless Flash Memory (W18/W30 SCSP) family with asynchronous RAM device.

The W18/W30 SCSP device provides flash + RAM die combinations. Products range from single flash die, two flash die, flash + PSRAM, or flash + SRAM. You can choose a W18 SCSP device or a W30 SCSP device with SRAM or PSRAM offered with the same package footprint and signal ballout.

Table 24 on page 63 lists possible product combinations for the 32-Mbit and 64-Mbit W18/W30 SCSP family.

2.1 Block Diagram

Figure 1 shows all internal package connections for the SCSP family with multiple die. See Table 24 for valid combinations of flash and RAM die. Unused connections on combinations with less than three die are reserved and should not be used.

Please contact your local Intel representative for details regarding any reserved or RFU pins.

Figure 1. Block Diagram

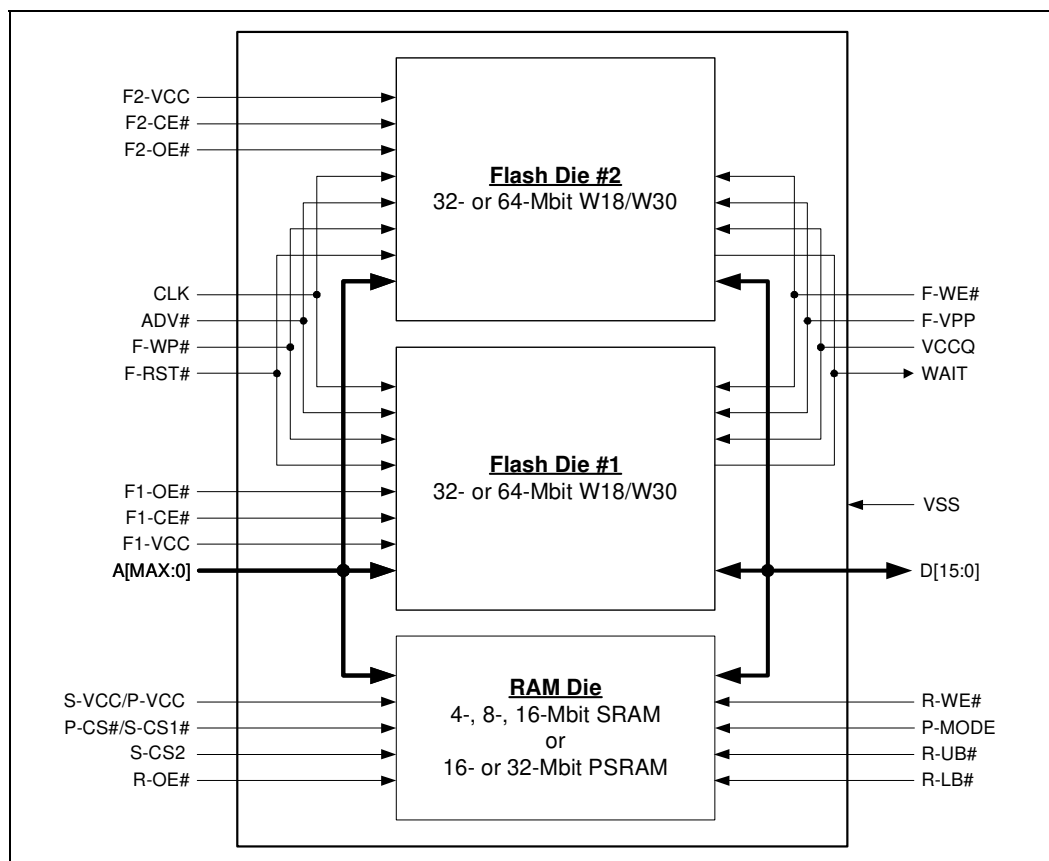

2.2 Flash Memory Map and Partitioning

Consult the latest *Intel® Wireless Flash Memory (W18) Datasheet* (order number 290701) and the *Intel® Wireless Flash Memory (W30) Datasheet* (order number 290702), for individual flash die memory map and partitioning information.

Table 1 and Table 2 show memory map and partitioning information for dual-flash memory die configurations. Flash Die #1 (with F1-CE# as its Chip Select) is configured as a bottom boot while Flash Die #2 (with F2-CE# as its Chip Select) is configured as top boot.

Table 1. 64-Mbit Flash + 32-Mbit Flash Die W18/W30 SCSP Memory Map and Partitioning

Partitioning			Block Size (KW)	Block #	Address Range
Flash Die #2 (32-Mbit)	Parameter Partition	Partition 0	4	63-70	1F8000-1FFFFFF
			32	56-62	1C0000-1F7FFF
	Main Partitions	Partition 1	32	48-55	180000-1BFFFF
		Partition 2	32	40-47	140000-17FFFF
		Partition 3	32	32-39	100000-13FFFF
		Partitions 4-7	32	0-31	000000-0FFFFFF
Flash Die #1 (64-Mbit)	Main Partitions	Partitions 8-15	32	71-134	200000-3FFFFFF
		Partitions 4-7	32	39-70	100000-1FFFFFF
		Partition 3	32	31-38	0C0000-0FFFFFF
		Partition 2	32	23-30	080000-0BFFFF
		Partition 1	32	15-22	040000-07FFFF
	Parameter Partition	Partition 0	32	8-14	008000-03FFFF
			4	0-7	000000-007FFF



Table 2. 64-Mbit Dual-Flash Die W18/W30 SCSP Memory Map and Partitioning

Partitioning			Block Size (KW)	Block #	Address Range
Top Parameter	Parameter Partition	Partition 0	4	127-134	3F8000-3FFFFFF
			32	120-126	3C0000-3F7FFF
	Main Partitions	Partition 1	32	112-119	380000-3BFFFF
		Partition 2	32	104-111	340000-37FFFF
		Partition 3	32	96-103	300000-33FFFF
		Partitions 4-7	32	64-95	200000-2FFFFFF
		Partitions 8-15	32	0-63	000000-1FFFFFF
Bottom Parameter	Main Partitions	Partitions 8-15	32	71-134	200000-3FFFFFF
		Partitions 4-7	32	39-70	100000-1FFFFFF
		Partition 3	32	31-38	0C0000-0FFFFFF
		Partition 2	32	23-30	080000-0BFFFF
		Partition 1	32	15-22	040000-07FFFF
	Parameter Partition	Partition 0	32	8-14	008000-03FFFF
			4	0-7	000000-007FFF

3.0 Package Information

The following packages are offered with the 32WQ and 64WQ Family :

- Figure 1, “Mechanical Specifications for 1- or 2-Die SCSP Device (8x10x1.2 mm)”
- Figure 2, “Mechanical Specifications for Triple-Die SCSP Device (8x10x1.4 mm)”

Figure 1. Mechanical Specifications for 1- or 2-Die SCSP Device (8x10x1.2 mm)

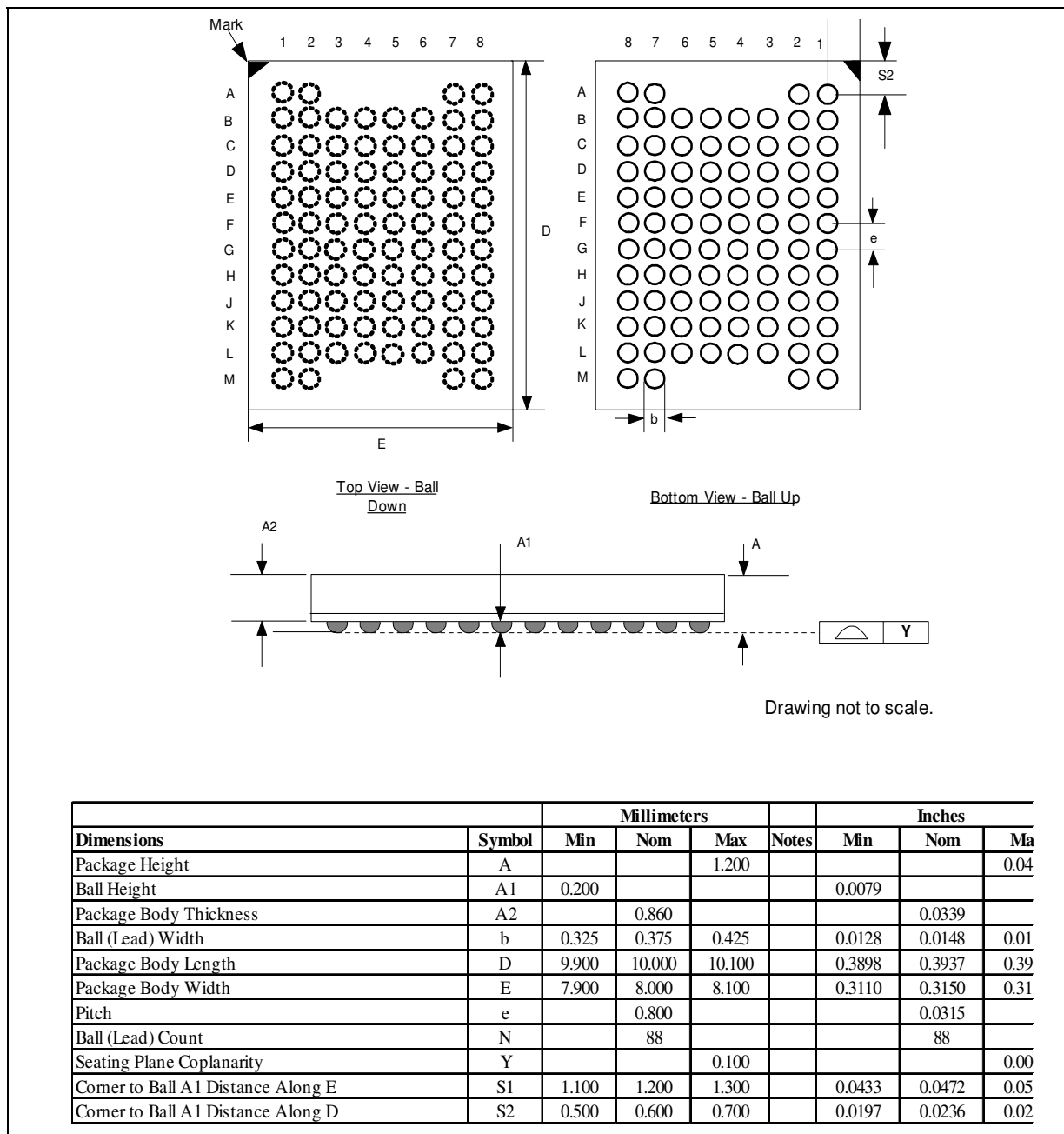
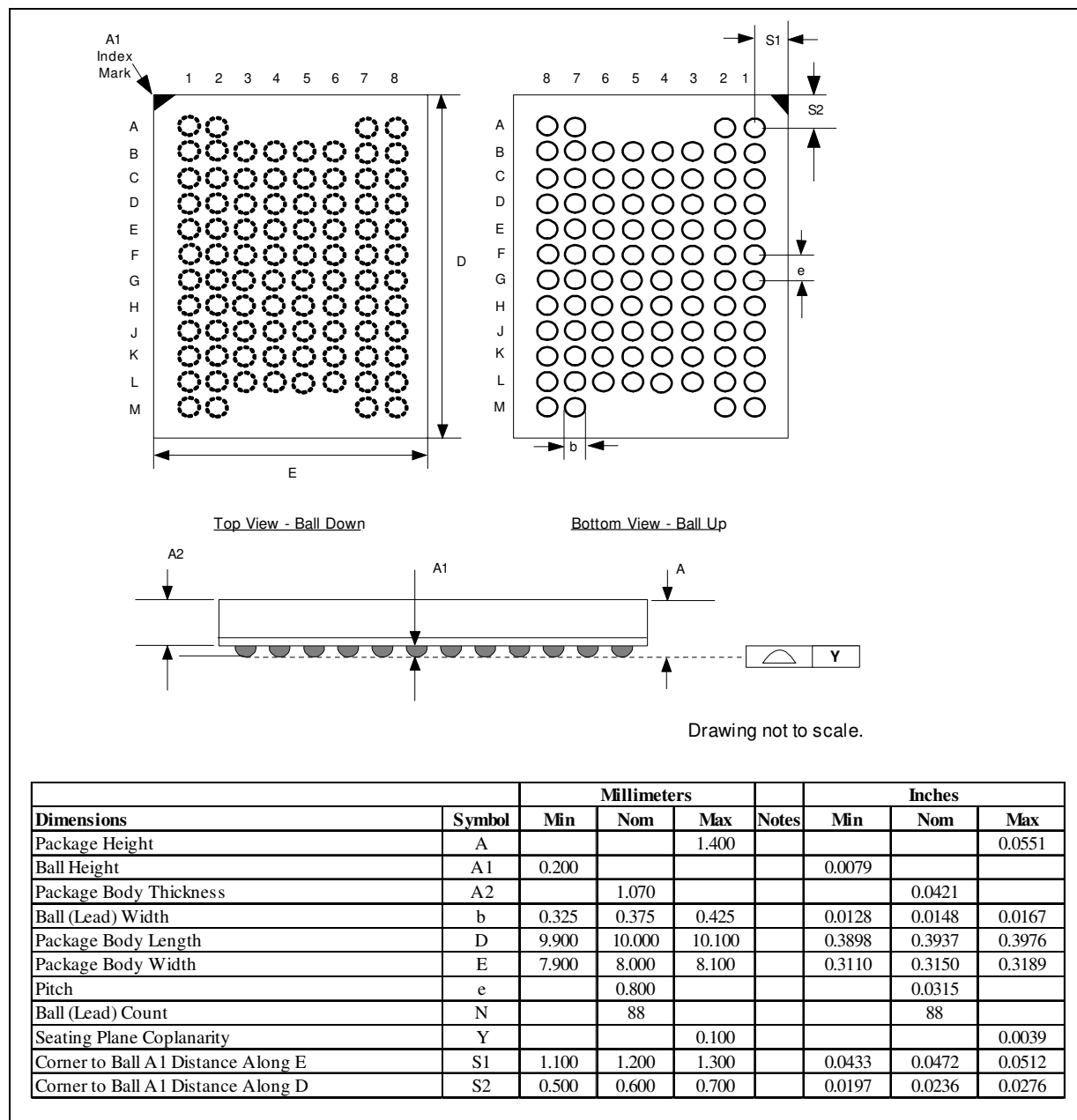

Figure 2. Mechanical Specifications for Triple-Die SCSP Device (8x10x1.4 mm)



4.0 Ballout and Signal Description

4.1 Signal Ballout

Figure 1 shows the 32WQ and 64WQ W18/W30 SCSP family 88-ball (8x10 active ball matrix) device.

Figure 1. 88-Ball (8x10 Active Ball Matrix) QUAD+ Ballout

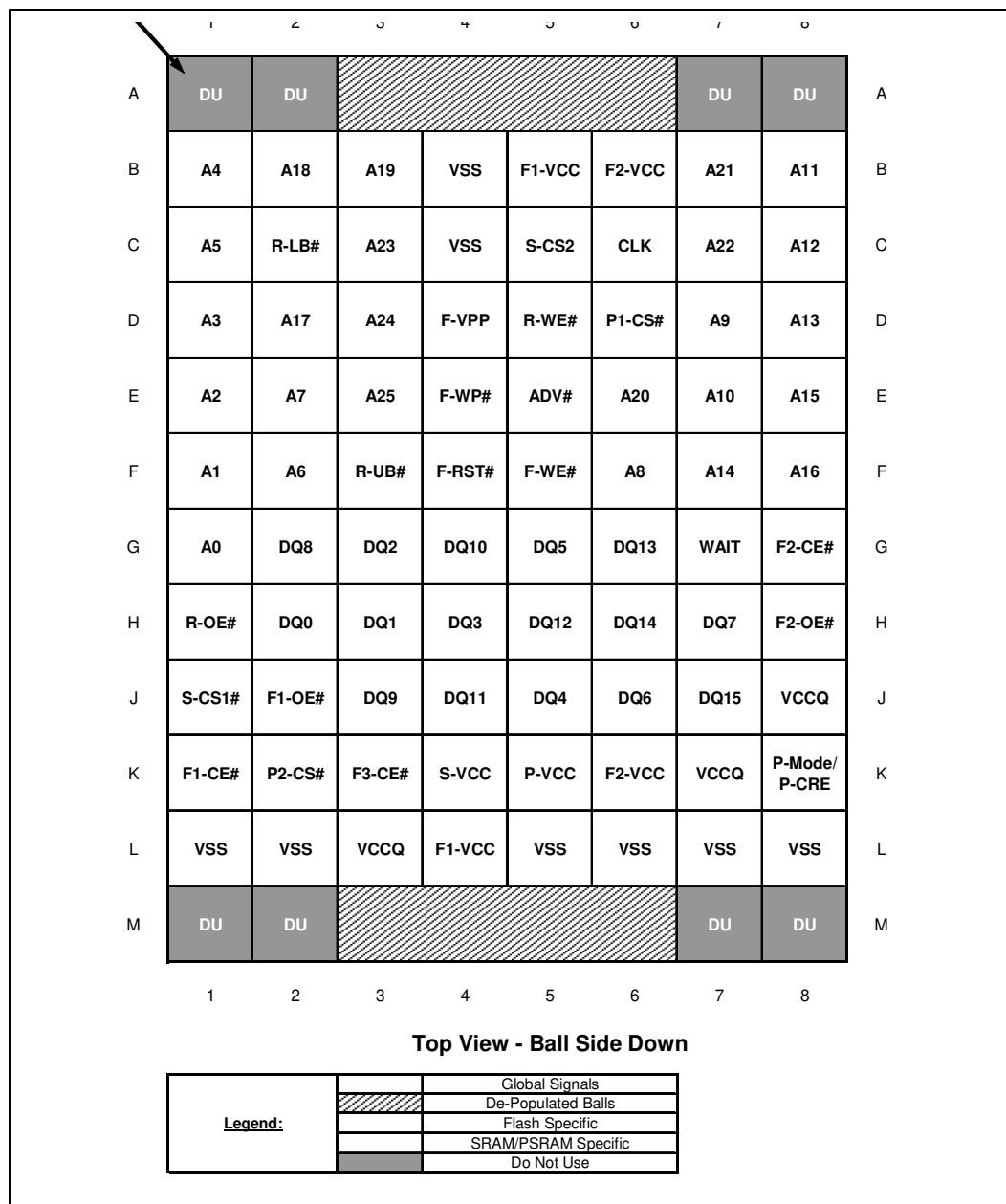

4.2 Signal Descriptions

Table 1 describes active signals used on the 32WQ and 64WQ W18/W30 SCSP family.

Table 1. Signal Descriptions (Sheet 1 of 2)

Symbol	Type	Name and Function
A[21:0]	Input	<p>ADDRESS INPUTS: Inputs for all die addresses during read and write operations. Addresses are internally latched during write operations.</p> <ul style="list-style-type: none"> • 4-Mbit: A[17:0] • 8-Mbit: A[18:0] • 16-Mbit: A[19:0] • 32-Mbit: A[20:0] • 64-Mbit: A[21:0] <p>A0 is the lowest-order word address. A[25:22] denote high-order addresses reserved for future device densities</p>
D[15:0]	Input/Output	<p>DATA INPUTS/OUTPUTS: Inputs data and commands during write cycles; outputs data during read cycles. Data signals float when the device or its outputs are deselected. Data are internally latched during writes.</p>
CLK	Input	<p>FLASH CLOCK: CLK synchronizes the selected flash die to the memory bus frequency in synchronous-read mode. During synchronous read operations, the initial address is latched on the rising edge of ADV#, or the rising/ falling edge of CLK when ADV# is low, whichever occurs first. CLK is only used in synchronous-read mode. Refer to the flash discrete product datasheet for information on how to use this signal in asynchronous-read mode.</p>
ADV#	Input	<p>FLASH ADDRESS VALID: Low-true; During synchronous read operations, the initial address is latched on the rising edge of ADV#, or the rising/ falling edge of CLK when ADV# is low, whichever occurs first.</p> <p>Refer to the flash discrete product datasheet for information on how to use this signal in asynchronous-read mode.</p>
WAIT	Output	<p>FLASH WAIT: When asserted, WAIT indicates invalid data from the selected flash die on D[15:0]. WAIT is High-Z whenever the flash die is deselected ($CE\# = V_{IL}$). WAIT is not gated by OE#.</p> <p>WAIT is only used in synchronous array-read mode. Refer to the flash discrete product datasheet for information on how to use this signal in asynchronous-read mode.</p>
F[3:1]-CE#	Input	<p>FLASH CHIP ENABLE: Low-true; CE#-low selects the associated flash memory die. When asserted, flash internal control logic, input buffers, decoders, and sense amplifiers are active. When deasserted, the associated flash die is deselected; power is reduced to standby levels, data and WAIT outputs are placed in High-Z.</p> <p>F1-CE# selects flash die #1; F2-CE# selects flash die #2 and is RFU on combinations with only one flash die. F3-CE# selects flash die #3 and is RFU on SCSP combinations with only one or two flash die.</p>
S-CS1# S-CS2	Input	<p>SRAM CHIP SELECTS: When both SRAM chip selects are asserted, SRAM internal control logic, input buffers, decoders, and sense amplifiers are active. When either/both SRAM chip selects are deasserted ($S-CS1\# = V_{IH}$ and/or $S-CS2 = V_{IL}$), the SRAM is deselected and its power is reduced to standby levels.</p> <p>S-CS1# and S-CS2 are only available on SCSP combinations with SRAM die.</p>
P[2:1]-CS#	Input	<p>PSRAM CHIP SELECTS: Low-true; When asserted, PSRAM internal control logic, input buffers, decoders, and sense amplifiers are active. When deasserted, the PSRAM is deselected and its power is reduced to standby levels.</p> <p>P1-CS# selects PSRAM die #1 and is available only on SCSP combinations with PSRAM die. This ball is RFU on SCSP combinations without PSRAM. P2-CS# selects PSRAM die #2 and is available only on SCSP combinations with two PSRAM die. This ball is RFU on SCSP combinations without PSRAM or with a single PSRAM.</p>

Table 1. Signal Descriptions (Sheet 2 of 2)

Symbol	Type	Name and Function
F[2:1]-OE#	Input	FLASH OUTPUT ENABLE: Low-true; OE#-low enables the flash output buffers. OE#-high disables the flash output buffers, and places the flash outputs in High-Z. F1-OE# controls the outputs of flash die #1; F2-OE# controls the outputs of flash die #2 and #3, and is available only on SCSP combinations with two or three flash die and is RFU on SCSP combinations with only one flash die.
R-OE#	Input	RAM OUTPUT ENABLE: Low-true; R-OE#-low enables the RAM output buffers. R-OE#-high disables the RAM output buffers, and places the RAM outputs in High-Z. R-OE# is only available on SCSP combinations with RAM die.
R-UB# R-LB#	Input	RAM UPPER/ LOWER BYTE ENABLES: Low-true; During RAM reads, R-UB#-low enables the RAM high-order bytes on D[15:8], and R-LB#-low enables the RAM low-order bytes on D[7:0]. R-UB# and R-LB# are only available on SCSP combinations with either SRAM die or PSRAM die.
F-WE#	Input	FLASH WRITE ENABLE: Low-true; WE# controls writes to the selected flash die. Address and data are latched on the rising edge of WE#.
R-WE#	Input	RAM WRITE ENABLE: Low-true; R-WE# controls writes to the RAM die. R-WE# is only available on SCSP combinations with RAM die.
F-WP#	Input	FLASH WRITE PROTECT: Low-true; WP# enables/disables the lock-down protection mechanism of the flash die. WP#-low enables the lock-down mechanism- locked down blocks cannot be unlocked with software commands. WP#-high disables the lock-down mechanism, allowing locked down blocks to be unlocked with software commands.
F-RST#	Input	FLASH RESET: Low-true; RST#-low initializes flash internal circuitry and disables flash operations. RST#-high enables flash operation. Exit from reset places the flash in asynchronous read array mode.
F-VPP F-VPEN	Power	FLASH PROGRAM/ ERASE POWER: A valid F-V _{PP} voltage on this ball enables flash program/erase operations. Flash memory array contents cannot be altered when F-V _{PP} (V _{PEN}) < V _{PPLK} (V _{PENLK}). Erase/ program operations at invalid F-V _{PP} (V _{PEN}) voltages should not be attempted. Refer to the flash discrete product datasheet for additional details. F-V _{PEN} (Erase/Program/Block Lock Enables) is not available for W18/W30 products.
P-MODE	Input	PSRAM MODE: Low-true; P-MODE is used to enter/exit low power mode. Low power mode is not applicable to 38F2020W0ZTQ1, 38F2020W0ZBQ1, 38F2030W0YTQ1, 38F2030W0YBQ1, 38F2030W0ZTQ2, 38F2030W0ZBQ2, 38F1030W0ZTQ0, 38F1030W0ZBQ0, 38F1030W0YTQE, 38F1030W0YBQE. P-Mode is only available on SCSP combinations with PSRAM die.
F[2:1]-VCC	Power	FLASH LOGIC Power: F1-VCC supplies power to the core logic of flash die #1; F2-VCC supplies power to the core logic of flash die #2 and #3. Write operations are inhibited when F-V _{CC} < V _{LKO} . Device operations at invalid F-V _{CC} voltages should not be attempted. F2-VCC is only available on SCSP combinations with two or three flash die, and is RFU on SCSP combinations with only one flash die.
S-VCC	Power	SRAM Power Supply: Supplies power to the SRAM die. S-VCC is only available on SCSP combinations with SRAM die.
P-VCC	Power	PSRAM Power Supply: Supplies power to the PSRAM die. P-VCC is only available on SCSP combinations with PSRAM die.
VCCQ	Power	FLASH OUTPUT-BUFFER Power: Supplies power for the I/O output buffers.
VSS	Power	Ground: Connect to ground. Do not float any VSS connection.
RFU	—	Reserved for Future Use: Reserve for future device functionality/ enhancements.
DU	—	Do Not Use: Do not connect to any other signal, or power supply; must be left floating.

5.0 Maximum Ratings and Operating Conditions

5.1 Absolute Maximum Ratings

Warning: Stressing the device beyond the “Absolute Maximum Ratings” may cause permanent damage. These are stress ratings only.

NOTICE: This document contains information available at the time of its release. The specifications are subject to change without notice. Verify with your local Intel sales office that you have the latest datasheet before finalizing a design.

Table 1. Absolute Maximum Ratings

Parameter		Min	Max	Unit	Notes
Temperature under Bias Expanded		-25	+85	°C	7
Storage Temperature		-55	+125	°C	
Voltage On Any Signal (except F[2:1]-V _{CC} , V _{CCQ} , F-V _{PP} , S-V _{CC} and P-V _{CC})	1.8 V I/O	-0.2	+2.45	V	1,2,3
	3.0 V I/O	-0.2	+3.6	V	2,3
F[2:1]-V _{CC} Voltage		-0.5	+2.45	V	2,3
V _{CCQ} , S-V _{CC} and P-V _{CC} Voltage	1.8 V I/O	-0.2	+2.45	V	1,2,3
	3.0 V I/O	-0.2	+3.6	V	2,3
F-V _{PP} Voltage		-0.2	+14.0	V	2,3,4,5
I _{SH} Output Short Circuit Current		-	100	mA	6

Notes:

- 90 nm is only avail with the 1.8 V I/O.
- All Specified voltages are relative to V_{SS}. Minimum DC voltage is -0.2 V on input/output signals, -0.2 V on F[2:1]-V_{CC} and F-V_{PP} signals. For 90 nm devices, during transitions, this level may overshoot to -1.5 V for periods < 20 ns, during transitions, may overshoot to F-V_{CC} + 1.5 V for periods < 20 ns.
- All Specified voltages are relative to V_{SS}. Minimum DC voltage is -0.2 V on input/output signals, -0.2 V on F[2:1]-V_{CC} and F-V_{PP} signals. For 130 nm devices, during transitions, this level may overshoot to -2 V for periods < 20 ns, during transitions, may overshoot to F-V_{CC} + 2 V for periods < 20 ns.
- Maximum DC voltage on F-V_{PP} may overshoot to +14.0 V for periods < 20 ns.
- F-V_{PP} program voltage is normally V_{PPL}. The maximum DC voltage on F-V_{PP} may overshoot to +14 V for periods < 20 ns. F-V_{PP} can be V_{PPH} for 1000 erase cycles on main blocks, 2500 cycles on parameter blocks.
- Output shorted for no more than one second. No more than one output shorted at a time.
- Devices available with -30° C temperature specifications are: 38F2020W0ZTQ1, 38F2020W0ZBQ1, 38F2030W0YTQ1, 38F2030W0YBQ1, 38F2030W0ZTQ2, 38F2030W0ZBQ2, 38F1030W0ZTQ0, 38F1030W0ZBQ0, 38F1030W0YTQE, 38F1030W0YBQE.

5.2 Operating Conditions

Warning: Operation beyond the “Operating Conditions” is not recommended and extended exposure beyond the “Operating Conditions” may affect device reliability.

Table 2. Operating Conditions

Symbol	Parameter	Flash + Flash		Flash + SRAM		Flash + PSRAM		Unit	Notes	
		Min	Max	Min	Max	Min	Max			
T_C	Operating Temperature	-25	+85	-25	+85	-25	+85	°C	2	
$F-V_{CC}$	Flash Supply Voltage	1.7	1.95	1.7	1.95	1.7	1.95	V		
V_{CCQ} $S-V_{CC}$ $P-V_{CC}$	Flash I/O Voltage	3.0 V I/O	2.2	3.3	2.2	3.3	2.7	3.1	V	
	PSRAM and SRAM Supply Voltage	1.8 V I/O	1.7	1.95	1.7	1.95	1.8	1.95	V	
V_{PPL}	Flash Program Logic Level	0.9	1.95	0.9	1.95	0.9	1.95	V		
V_{PPH}	Flash Factory Program Voltage	11.4	12.6	11.4	12.6	11.4	12.6	V	1	
Note: 1. $F-V_{PP}$ is normally V_{PPL} . $F-V_{PP}$ can be connected to 11.4 V–12.6 V for 1000 cycles on main blocks for extended temperatures and 2500 cycles on parameter blocks at extended temperature. 2. Devices available with -30 C temperature specifications are: 38F2020W0ZTQ1, 38F2020W0ZBQ1, 38F2030W0YTQ1, 38F2030W0YBQ1, 38F2030W0ZTQ2, 38F2030W0ZBQ2, 38F1030W0ZTQ0, 38F1030W0ZBQ0, 38F1030W0YTQE, 38F1030W0YBQE.										

5.3 Capacitance

NOTICE: Refer to the *1.8-Volt Intel® Wireless Flash Memory Datasheet* (order number 290701) and *1.8-Volt Intel® Wireless Flash Memory with 3 Volt I/O Datasheet* (order number 290702) for flash capacitance details. For SCSP products with two flash die, flash capacitances for each of the flash die need to be considered accordingly.

Table 3. SRAM, PSRAM Capacitance

Symbol	Parameter	Typ	Unit	Condition
C_{IN}	Input Capacitance	10	pF	$V_{IN} = 0.0\text{ V}$, $T_C = 25\text{ °C}$, $f = 1\text{ MHz}$
C_{OUT}	Output Capacitance	10	pF	$V_{OUT} = 0.0\text{ V}$, $T_C = 25\text{ °C}$, $f = 1\text{ MHz}$

6.0 Electrical Specifications

6.1 DC Characteristics

SRAM and PSRAM DC characteristics are shown in [Table 1](#), [Table 2](#) and [Table 3](#). Refer to the *Intel® Wireless Flash Memory (W18) Datasheet* (order number 290701) and the *Intel® Wireless Flash Memory (W30) Datasheet* (order number 290702) for flash DC characteristics.

NOTICE: DC Characteristics of all die in a SCSP device need to be considered accordingly, depending on the SCSP device operation.

Table 1. SRAM DC Characteristics (Sheet 1 of 2)

Parameter	Description	Test Conditions	1.8 V SRAM		3.0 V SRAM		Unit	
			Min	Max	Min	Max		
S-V _{CC}	Voltage Range		1.7	1.95	2.2	3.3	V	
V _{DR}	V _{CC} for Data Retention		1.0	–	1.5	–	V	
I _{CC}	Operating Current at min cycle time	I _{IO} = 0 mA	4M	–	25	–	45	mA
			8M	–	35	–	50	
			16M	–	40	–	55	
I _{CC2}	Operating Current at max cycle time (1 μs)	I _{IO} = 0 mA	4M	–	4	–	10	mA
			8M	–	6	–	10	
			16M	–	10	–	15	
I _{SB}	Standby Current	S-CS1# ≥ S-V _{CC} -0.2V or S-CS2 ≤ V _{SS} +0.2V Address/Data toggling at minimum cycle time	4M	–	12	–	15	μA
			8M	–	20	–	25	
			16M	–	30	–	45	
I _{DR}	Current in Data Retention mode	1.8 V SRAM: S-V _{CC} = 1.0 V 3.0 V SRAM: S-V _{CC} = 1.5 V	4M	–	6	–	5	μA
			8M	–	10	–	12	
			16M	–	18	–	15	
V _{OH}	Output HIGH Voltage	I _{OH} = -100 μA	S-V _{CC} -0.15	–	S-V _{CC} -0.1	–	V	
V _{OL}	Output LOW Voltage	I _{OL} = 100 μA, V _{CCMIN}	-0.1	0.2	-0.1	0.1	V	
V _{IH}	Input HIGH Voltage		S-V _{CC} -0.4	S-V _{CC} +0.2	S-V _{CC} -0.4	S-V _{CC} +0.2	V	
V _{IL}	Input LOW Voltage		-0.2	0.4	-0.2	0.6	V	
I _{OH}	Output HIGH Current		–	–	–	–	mA	
I _{OL}	Output LOW Current		–	–	–	–	mA	

Table 1. SRAM DC Characteristics (Sheet 2 of 2)

*I _{IL}	Input Leakage Current	-0.2 < V _{IN} < S-V _{CC} + 0.2 V	-1	+1	-1	+1	μA
*I _{LDR}	Input Leakage Current in Data Retention Mode	-0.2 < V _{IN} < S-V _{CC} + 0.2 V S-V _{CC} = V _{DR}	-1	+1	-1	+1	μA

* Input leakage currents include Hi-Z output leakage for bi-directional buffers with tri-state outputs.

Table 2. PSRAM DC Characteristics

Parameter	Description	Test Conditions	1.8 V PSRAM		3.0 V PSRAM		Unit	Note
			Min	Max	Min	Max		
V _{CC}	Voltage Range		1.8	1.95	2.7	3.1	V	3
I _{CC}	Operating Current at min cycle time	I _{IO} = 0 mA	16M	–	–	35	mA	2, 3
			32M	–	35	45		
I _{CC2}	Operating Current at max cycle time (1 μs)	I _{IO} = 0 mA	16M	–	–	7	mA	2, 3
			32M	–	–	7		
I _{SB}	Standby Current	P-CS# ≥ P-V _{CC} - 0.2V or P-Mode ≥ P-V _{CC} - 0.2V Address/Data toggling at minimum cycle time	16M	–	–	85	μA	2, 3
			32M	–	100	100		
I _{sbD}	Deep Power-Down	P-Mode ≤ 0.2 V	16M	–	–	10	μA	2, 3
			32M	–	30	10		
V _{OH}	Output HIGH Voltage	I _{OH} = -0.5 mA	0.8P-V _{CC}	–	2.4	–	V	3
V _{OL}	Output LOW Voltage	I _{OL} = 1 mA,	–	0.2P-V _{CC}	–	0.4	V	3
V _{IH}	Input HIGH Voltage		0.8P-V _{CC}	P-V _{CC} +0.3	P-V _{CC} - 0.3	P-V _{CC} + 0.2	V	3
V _{IL}	Input LOW Voltage		-0.3	0.2P-V _{CC}	-0.2	0.5	V	3
I _{OH}	Output HIGH Current		–	–	–	–	mA	2, 3
I _{OL}	Output LOW Current		–	–	–	–	mA	2, 3
I _{IL}	Input Leakage Current	-0.2 < V _{IN} < P-V _{CC} +0.2 V	-1	+1	-1	+1	μA	1, 2, 3
I _{OL}	Output Leakage Current	-0.2 < V _{IN} < P-V _{CC} +0.5 V P-V _{CC} = V _{DR}	-1	+1	-1	+1	μA	1, 2, 3

Notes:

1. Input Leakage currents include Hi-Z output leakage for bi-directional buffers with tri-state outputs.
2. All currents are in RMS unless noted otherwise.
3. Not applicable to 38F2020W0ZTQ1, 38F2020W0ZBQ1, 38F2030W0YTQ1, 38F2030W0YBQ1, 38F2030W0ZTQ2, 38F2030W0ZBQ2, 38F1030W0ZTQ0, 38F1030W0ZBQ0, 38F1030W0YTQE, 38F1030W0YBQE.

Table 3. PSRAM DC Characteristics

Parameter	Description	Test Conditions	1.8 V PSRAM		3.0 V PSRAM		Unit	Note	
			Min	Max	Min	Max			
V_{CC}	Voltage Range		1.8	1.95	2.7	3.1	V	3	
I_{CC}	Operating Current at min cycle time	$I_{IO} = 0$ mA	8M	–	–	–	30	mA	2, 3
			16M	–	30	–	35		
I_{CC2}	Operating Current at max cycle time (1 μ s)	$I_{IO} = 0$ mA	8M	–	–	–	5	mA	2, 3
			16M	–	5	–	7		
I_{SB}	Standby Current	P-CS# \geq P- V_{CC} -0.2V. All inputs stable (either high or low)	8M	–	–	–	80	μ A	2, 3
			16M	–	100	–	100		
V_{OH}	Output HIGH Voltage	$I_{OH} = -0.1$ mA	1.4	–	P- V_{CC} -0.3	–	V	3	
V_{OL}	Output LOW Voltage	$I_{OL} = 0.1$ mA, V_{CCMin}	-0.1	0.2	-0.1	0.3	V	3	
V_{IH}	Input HIGH Voltage		P- V_{CC} -0.3	P- V_{CC} +0.2	P- V_{CC} -0.4	P- V_{CC} +0.2	V	3	
V_{IL}	Input LOW Voltage		-0.2	0.4	-0.2	0.6	V	3	
I_{OH}	Output HIGH Current		–	–	–	–	mA	2, 3	
I_{OL}	Output LOW Current		–	–	–	–	mA	2, 3	
I_{IL}	Input Leakage Current	$-0.2 < V_{IN} < P-V_{CC} + 0.2$ V	-1	+1	-1	+1	μ A	1, 2, 3	
I_{OL}	Output Leakage Current	$-0.2 < V_{IN} < P-V_{CC} + 0.2$ V P- $V_{CC} = V_{DR}$	-1	+1	-1	+1	μ A	1, 2, 3	

Notes:

1. Input Leakage currents include Hi-Z output leakage for bi-directional buffers with tri-state outputs.
2. All currents are in RMS unless noted otherwise.
3. Applicable to 38F2020W0ZTQ1, 38F2020W0ZBQ1, 38F2030W0YTQ1, 38F2030W0YBQ1, 38F2030W0ZTQ2, 38F2030W0ZBQ2, 38F1030W0ZTQ0, 38F1030W0ZBQ0, 38F1030W0YTQE, 38F1030W0YBQE.

7.0 AC Characteristics

7.1 Flash AC Characteristics

Refer to the *Intel^E Wireless Flash Memory (W18) Datasheet* (order number 290701) and *Intel^E Wireless Flash Memory (W30) Datasheet* (order number 290702) for flash AC characteristics details not included in Table 10 below.

Table 10. Flash AC Read Characteristics

Nbr	Sym	Parameter	W18		W30		Unit
			Min	Max	Min	Max	
Asynchronous Specifications							
R1	t_{AVAV}	Read Cycle Time	65	—	70	—	ns
R2	t_{AVQV}	Address to Output Delay	—	65	—	70	ns
R3	t_{ELQV}	CE# Low to Output Delay	—	65	—	70	ns
Latching Specifications							
R103	t_{VLQV}	ADV# Low to Output Delay	—	65	—	70	ns
R108	t_{APA}	Page Address Access Time	—	25	—	25	ns
Clock Specifications							
R304	t_{CHQV}	CLK to Output Delay	—	14	—	20	ns

7.2 SRAM AC Characteristics

Table 11. SRAM AC Characteristics — Read Operations

#	Symbol	Parameter	Min	Max	Unit	Notes
R1	t_{RC}	Read Cycle Time	70	—	ns	1
R2	t_{AA}	Address to Output Delay	—	70	ns	1
R3	t_{CO1}	S-CS1# to Output Delay	—	70	ns	1
R3	t_{CO2}	S-CS2 to Output Delay	—	70	ns	1
R4	t_{OE}	R-OE# to Output Delay	—	35	ns	1
R5	t_{BA}	R-UB#, R-LB# to Output Delay	—	70	ns	1
R6	t_{LZ}	S-CS1# or S-CS2 to Output in Low-Z	5	—	ns	1,3,4
R7	t_{OLZ}	R-OE# to Output in Low-Z	0	—	ns	1,4
R8	t_{HZ}	S-CS1# or S-CS2 to Output in High-Z	0	25	ns	1,2,3,4
R9	t_{OHZ}	R-OE# to Output in High-Z	0	25	ns	1,2,4
R10	t_{OH}	Output Hold (from Address, S-CS1#, S-CS2 or R-OE# Change, whichever occurs first)	0	—	ns	1

Table 11. SRAM AC Characteristics — Read Operations

#	Symbol	Parameter	Min	Max	Unit	Notes
R11	t_{BLZ}	R-UB#, R-LB# to Output in Low-Z	0	–	ns	1,4
R12	t_{BHZ}	R-UB#, R-LB# to Output in High-Z	0	25	ns	1,4

Note:

1. See Figure 5, “AC Waveform SRAM Read Operations”.
2. Timings of t_{HZ} and t_{OHZ} are defined as the time at which the outputs achieve the open circuit conditions and are not referenced to output voltage levels.
3. At any given temperature and voltage condition, t_{HZ} (Max) is less than t_{LZ} (Max) both for a given device and from device to device interconnection.
4. Sampled but not 100% tested.

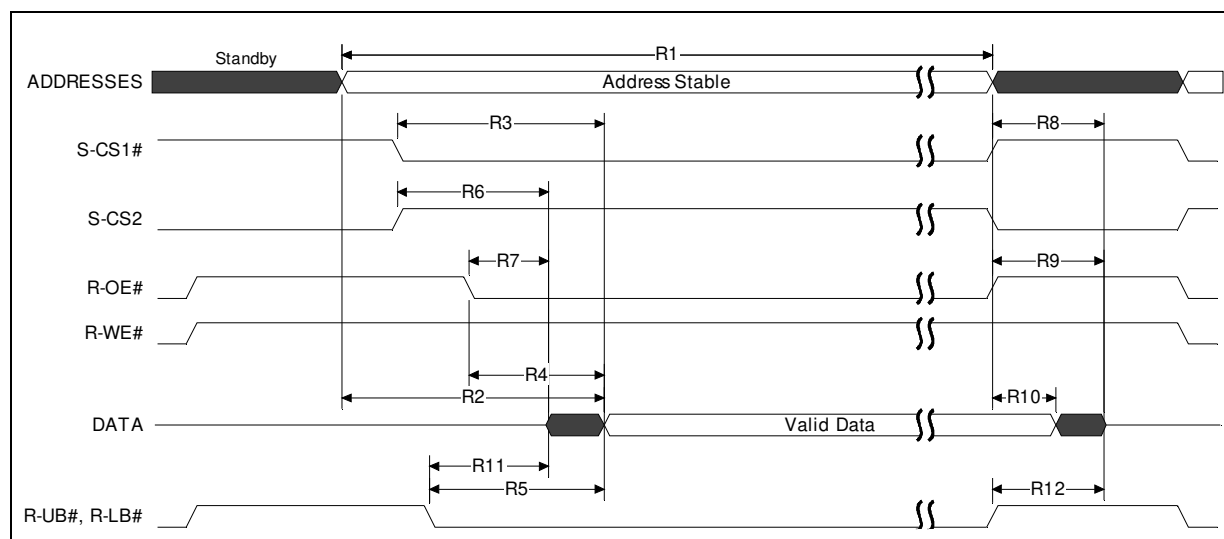
Figure 5. AC Waveform SRAM Read Operations**Table 12. SRAM AC Characteristics — Write Operations**

#	Symbol	Parameter	Min	Max	Unit	Notes
W1	t_{WC}	Write Cycle Time	70	–	ns	1
W2	t_{AS}	Address Setup to R-WE# (S-CS1#) and R-UB#/R-LB# Low	0	–	ns	1,4
W3	t_{WP}	R-WE# (S-CS1#) Pulse Width	55	–	ns	1,2,3
W4	t_{DW}	Data to Write Time Overlap	30	–	ns	1
W5	t_{AW}	Address Setup to R-WE# (S-CS1#) High	60	–	ns	1
W6	t_{CW}	S-CS1# (R-WE#) Setup to R-WE# (S-CS1#) High	60	–	ns	1
W7	t_{DH}	Data Hold from R-WE# (S-CS1#) High	0	–	ns	1

Table 12. SRAM AC Characteristics — Write Operations

W8	t_{WR}	Write Recovery	0	–	ns	1,5
W9	t_{BW}	R-UB#, R-LB# Setup to R-WE# (S-CS1#) High	60	–	ns	1

Notes:

1. See Figure 6, “AC Waveform SRAM Write Operations”.
2. A write occurs during the overlap (t_{WP}) of low S-CS1# and low R-WE#. A write begins when S-CS1# goes low and R-WE# goes low with asserting R-UB# and R-LB# for single byte operation or simultaneously asserting R-UB#R-LB# and R-LB# for double byte operation. A write ends at the earliest high transition of S-CS1# and R-WE#.
3. t_{WP} is measured from S-CS1# low to the end of a write.
4. t_{AS} is measured from the address valid to the beginning of a write.
5. t_{WR} is measured from the end of write to the address change. t_{WR} applied in case a write ends as S-CS1# or R-WE# goes high.

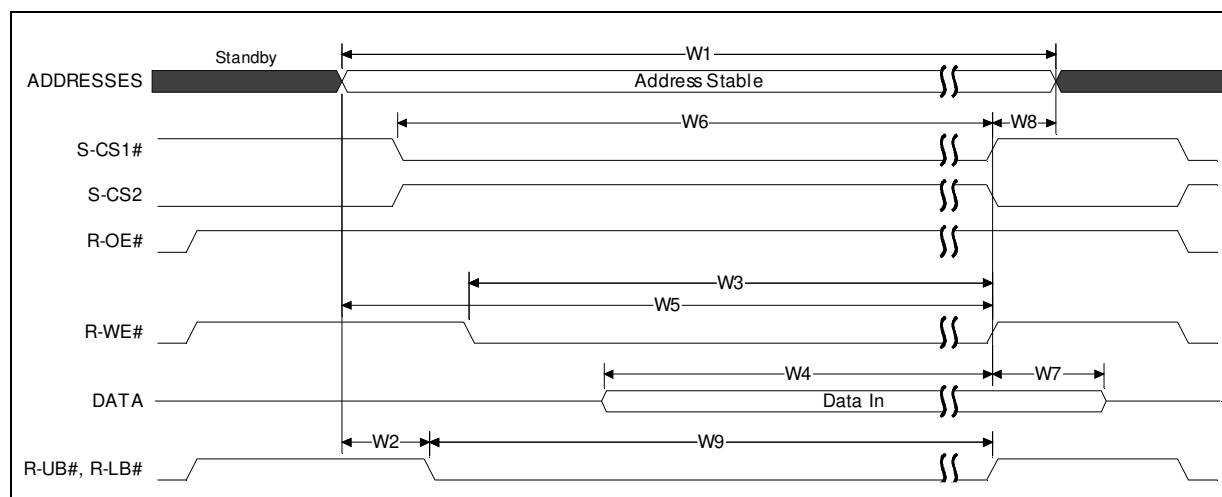
Figure 6. AC Waveform SRAM Write Operations

7.3 PSRAM AC Characteristics

Table 13. PSRAM AC Characteristics — Read Operations

#	Symbol	Parameter ⁶	1.8 V		3.0 V		Unit	Notes
			Min	Max	Min	Max		
R1	t_{RC}	Read Cycle Time	88	4,000	85	4,000	ns	1
R2	t_{AA}	Address to Output Delay	–	88	–	85	ns	1
R3	t_{CO}	P-CS# to Output Delay	–	88	–	85	ns	1
R4	t_{OE}	R-OE# to Output Delay	–	65	–	40	ns	1
R5	t_{BA}	R-UB#, R-LB# to Output Delay	–	88	–	85	ns	1
R6	t_{LZ}	P-CS# to Output in Low-Z	10	–	10	–	ns	1,3,4
R7	t_{OLZ}	R-OE# to Output in Low-Z	5	–	0	–	ns	1,4
R8	t_{HZ}	P-CS# to Output in High-Z	–	25	0	25	ns	1,2,3,4
R9	t_{OHZ}	R-OE# to Output in High-Z	–	25	0	25	ns	1,2,4

Table 13. PSRAM AC Characteristics — Read Operations

#	Symbol	Parameter ⁶	1.8 V		3.0 V		Unit	Notes
			Min	Max	Min	Max		
R10	t _{OH}	Output Hold (from Address, P-CS# or R-OE# change, whichever occurs first)	5	–	0	–	ns	1
R11	t _{BLZ}	R-UB#, R-LB# to Output in Low-Z	5	–	0	–	ns	1,4
R12	t _{BHZ}	R-UB#, R-LB# to Output in High-Z	–	25	0	25	ns	1,4
PR1	t _{PC}	Page Cycle Time	30	–	40	–	ns	5
PR2	t _{PA}	Page Access Time	–	30	–	35	ns	5

Note:

- See Figure 7, “AC Waveform of PSRAM Read Operations” on page 27 and Figure 8, “AC Waveform of PSRAM 4-Word Page Read Operation” on page 27
- Timings of t_{HZ} and t_{OHZ} are defined as the time at which the outputs achieve the open circuit conditions and are not referenced to output voltage levels.
- At any given temperature and voltage condition, t_{HZ} (Max) is less than t_{LZ} (Max) both for a given device and from device to device interconnection.
- Sampled but not 100% tested.
- 4-Word Page read only available for 32-Mbit PSRAM. No page mode feature for 16-Mbit PSRAM.
- Not applicable to 38F2020W0ZTQ1, 38F2020W0ZBQ1, 38F2030W0YTQ1, 38F2030W0YBQ1, 38F2030W0ZTQ2, 38F2030W0ZBQ2, 38F1030W0ZTQ0, 38F1030W0ZBQ0, 38F1030W0YTQE, 38F1030W0YBQE.

Table 14. PSRAM AC Characteristics — Read Operations (Sheet 1 of 2)

#	Symbol	Parameter ⁶	1.8 V		3.0 V		Unit	Notes
			Min	Max	Min	Max		
R1	t _{RC}	Read Cycle Time	70	15000	70	15000	ns	
R2	t _{AA}	Address to Output Delay	–	70	–	70	ns	
R3	t _{CO}	P-CS# to Output Delay	–	70	–	70	ns	
R4	t _{OE}	R-OE# to Output Delay	–	45	–	45	ns	
R5	t _{BA}	R-UB#, R-LB# to Output Delay	–	70	–	70	ns	
R6	t _{LZ}	P-CS# to Output in Low-Z	5	–	5	–	ns	3
R7	t _{OLZ}	R-OE# to Output in Low-Z	0	–	0	–	ns	
R8	t _{HZ}	P-CS# to Output in High-Z	0	25	0	25	ns	2, 3
R9	t _{OHZ}	R-OE# to Output in High-Z	0	25	0	25	ns	2
R10	t _{OH}	Output Hold (from Address, P-CS# or R-OE# change, whichever occurs first)	0	–	0	–	ns	
R11	t _{BLZ}	R-UB#, R-LB# to Output in Low-Z	0	–	0	–	ns	
R12	t _{BHZ}	R-UB#, R-LB# to Output in High-Z	0	25	0	25	ns	

Table 14. PSRAM AC Characteristics — Read Operations (Sheet 2 of 2)

#	Symbol	Parameter ⁶	1.8 V		3.0 V		Unit	Notes
			Min	Max	Min	Max		
PR1	t _{PC}	Page Cycle Time	25	–	25	–	ns	4
PR2	t _{PA}	Page Access Time	–	25	–	25	ns	4

Note:

- See Figure 7, “AC Waveform of PSRAM Read Operations” on page 27 and Figure 8, “AC Waveform of PSRAM 4-Word Page Read Operation” on page 27
- Timings of t_{HZ} and t_{OHZ} are defined as the time at which the outputs achieve the open circuit conditions and are not referenced to output voltage levels.
- At any given temperature and voltage condition, t_{HZ} (Max) is less than t_{LZ} (Max) both for a given device and from device to device interconnection.
- 4-Word Page read only available for 16-Mbit PSRAM. No page mode feature for 8-Mbit PSRAM.
- 8-Mbit has additional skew limitation of 10 ns. 16-Mbit does not have this limitation.
- Applicable to 38F2020W0ZTQ1, 38F2020W0ZBQ1, 38F2030W0YTQ1, 38F2030W0YBQ1, 38F2030W0ZTQ2, 38F2030W0ZBQ2, 38F1030W0ZTQ0, 38F1030W0ZBQ0, 38F1030W0YTQE, 38F1030W0YBQE.

Table 15. PSRAM AC Characteristics—Write Operations

#	Symbol	Parameter ⁶	1.8 V		3.0 V		Unit	Notes
			Min	Max	Min	Max		
W1	t _{WC}	Write Cycle Time	85	4,000	85	4,000	ns	1
W2	t _{AS}	Address Setup to R-WE# (P-CS#) and R-UB#, R-LB# going low	0	–	0	–	ns	1,4
W3	t _{WP}	R-WE#(P-CS#) Pulse Width	60	–	85	–	ns	1,2,3
W4	t _{DW}	Data to Write Time Overlap	30	–	35	–	ns	1
W5	t _{AW}	Address Setup to R-WE# (P-CS#) Going High	70	–	70	–	ns	1
W6	t _{CW}	P-CS# (R-WE#) Setup to R-WE# (P-CS#) Going High	70	–	70	–	ns	1
W7	t _{DH}	Data Hold from R-WE# (P-CS#) High	0	–	0	–	ns	1
W8	t _{WR}	Write Recovery	0	–	20	–	ns	1,5
W9	t _{BW}	R-UB#, R-LB# Setup to R-WE# (P-CS#) Going High	70	–	70	–	ns	1

Notes:

- See Figure 9, “AC Waveform PSRAM Write Operation” .
- A write occurs during the overlap (t_{WP}) of low P-CS# and low R-WE#. A write begins when P-CS# goes low and R-WE# goes low with asserting R-UB# or R-LB# for single byte operation or simultaneously asserting R-UB# and R-LB# for double byte operation. A write ends at the earliest transition when P-CS# goes high and R-WE# goes high. The t_{WP} is measured from the beginning to the end of a write.
- t_{WP} is measured from P-CS# going low to end of a write.
- t_{AS} is measured from the address valid to the beginning of a write.
- t_{WR} is measured from the end of a write to the address change. t_{WR} applied in case a write ends as P-CS# or R-WE# going high.
- Not applicable to 38F2020W0ZTQ1, 38F2020W0ZBQ1, 38F2030W0YTQ1, 38F2030W0YBQ1, 38F2030W0ZTQ2, 38F2030W0ZBQ2, 38F1030W0ZTQ0, 38F1030W0ZBQ0, 38F1030W0YTQE, 38F1030W0YBQE.

Table 16. PSRAM AC Characteristics—Write Operations

#	Symbol	Parameter ⁷	1.8 V		3.0 V		Unit	Notes
			Min	Max	Min	Max		
W1	t_{WC}	Write Cycle Time	70	–	70	–	ns	1
W2	t_{AS}	Address Setup to R-WE# (P-CS#) and R-UB#, R-LB# going low	0	–	0	–	ns	1,4
W3	t_{WP}	R-WE#(P-CS#) Pulse Width	55	–	55	–	ns	1,2,3
W4	t_{DW}	Data to Write Time Overlap	35	–	35	–	ns	1
W5	t_{AW}	Address Setup to R-WE# (P-CS#) Going High	60	–	60	–	ns	1
W6	t_{CW}	P-CS# (R-WE#) Setup to R-WE# (P-CS#) Going High	60	–	60	–	ns	1
W7	t_{DH}	Data Hold from R-WE# (P-CS#) High	0	–	0	–	ns	1
W8	t_{WR}	Write Recovery	0	–	0	–	ns	1,5
W9	t_{BW}	R-UB#, R-LB# Setup to R-WE# (P-CS#) Going High	60	–	60	–	ns	1

Notes:

- See [Figure 9, “AC Waveform PSRAM Write Operation”](#).
- A write occurs during the overlap (t_{WP}) of low P-CS# and low R-WE#. A write begins when P-CS# goes low and R-WE# goes low with asserting R-UB# or R-LB# for single byte operation or simultaneously asserting R-UB# and R-LB# for double byte operation. A write ends at the earliest transition when P-CS# goes high and R-WE# goes high.
- t_{WP} is measured from P-CS# going low to end of a write.
- t_{AS} is measured from the address valid to the beginning of a write.
- t_{WR} is measured from the end of a write to the address change. t_{WR} applied in case a write ends as P-CS# or R-WE# going high.
- W3 is 70 ns for continuous write operations over 50 times.
- Applicable to 38F2020W0ZTQ1, 38F2020W0ZBQ1, 38F2030W0YTQ1, 38F2030W0YBQ1, 38F2030W0ZTQ2, 38F2030W0ZBQ2, 38F1030W0ZTQ0, 38F1030W0ZBQ0, 38F1030W0YTQE, 38F1030W0YBQE.

Figure 7. AC Waveform of PSRAM Read Operations

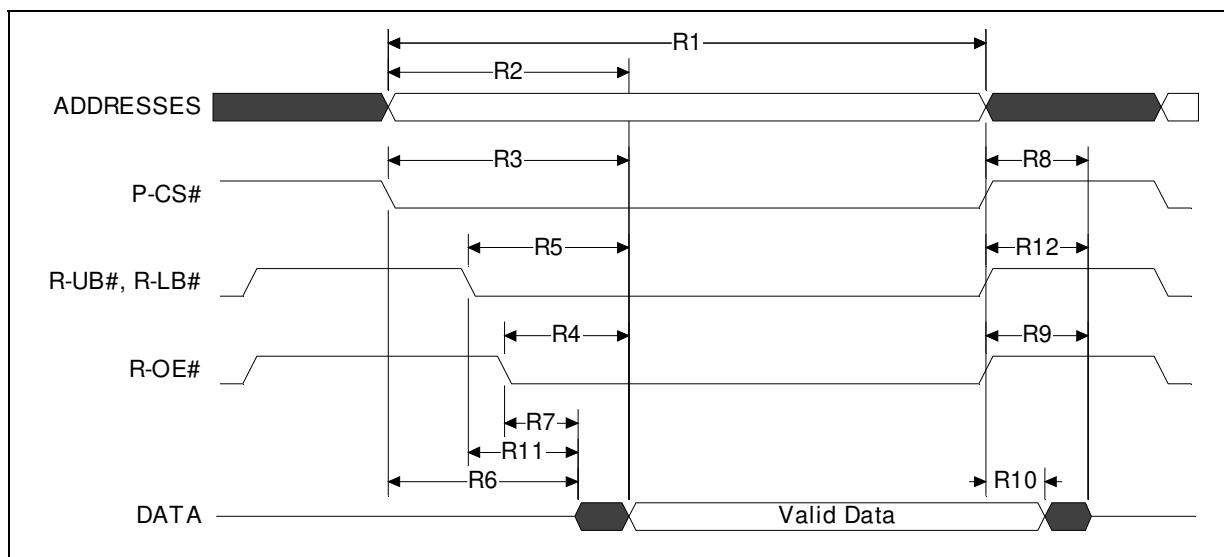
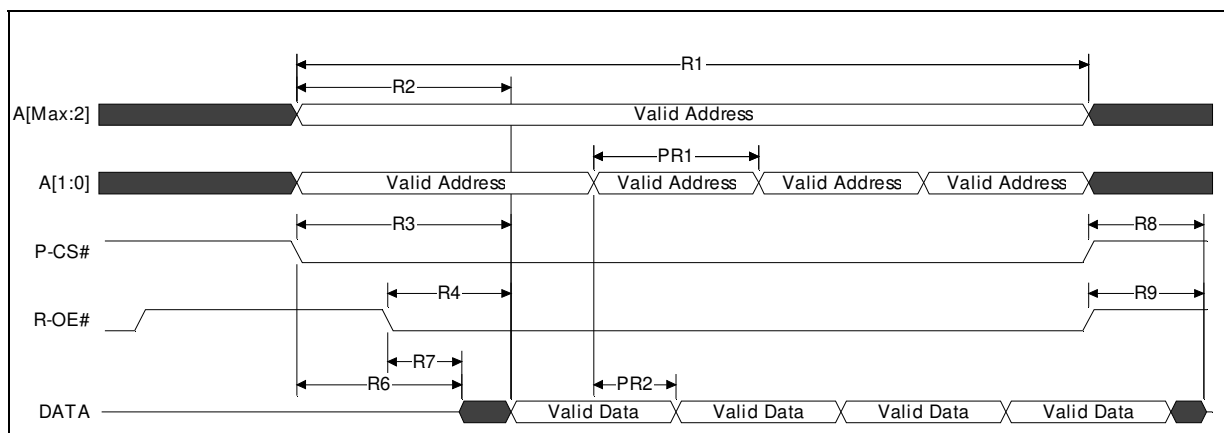
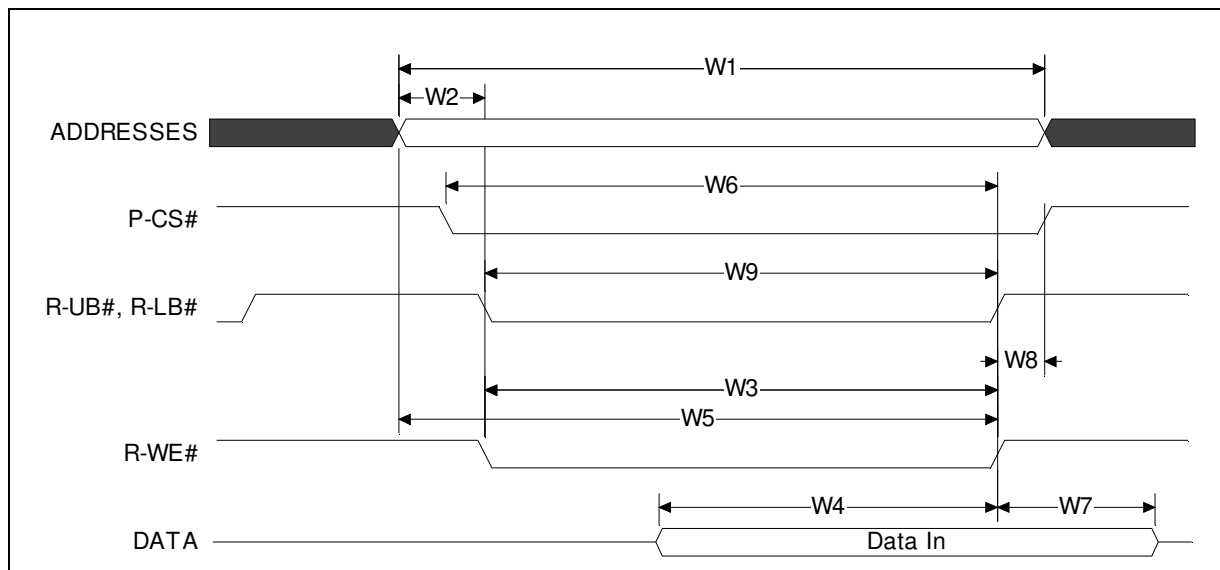

Figure 8. AC Waveform of PSRAM 4-Word Page Read Operation



Note: Available only for 32-Mbit PSRAM and line items with 16-Mbit PSRAM (70 ns) 38F2030W0YTQ1, 38F2030W0YBQ1, 38F2030W0ZTQ2, 38F2030W0ZBQ2, 38F1030W0ZTQ0, 38F1030W0ZBQ0, 38F1030W0YTQE, 38F1030W0YBQE. Not applicable to 8-Mbit PSRAM.

Figure 9. AC Waveform PSRAM Write Operation



7.4 Device AC Test Conditions

Figure 10. Transient Input/Output Reference Waveform

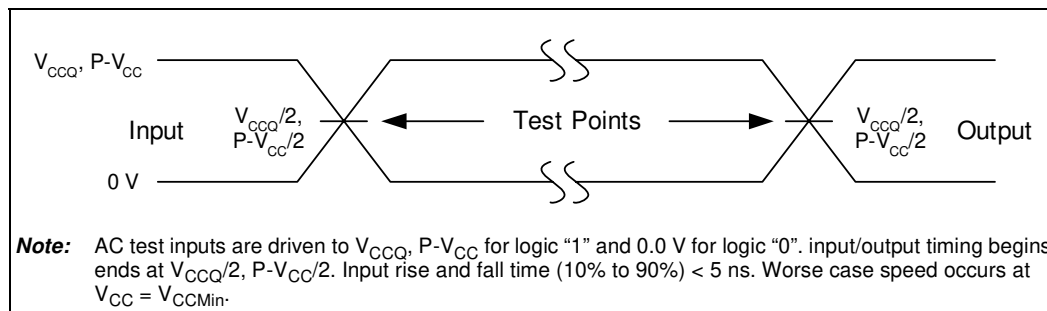
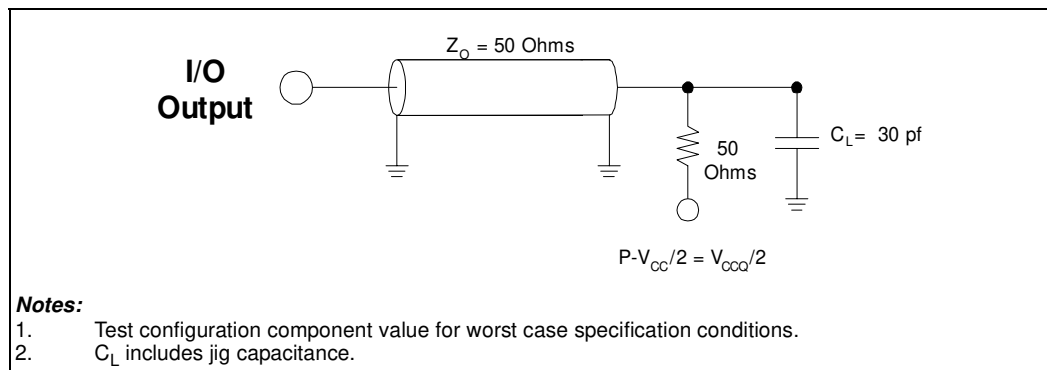

Figure 11. Transient Equivalent Testing Load Circuit





8.0 Flash Power Consumption

Refer to the *Intel[®] Wireless Flash Memory (W18) Datasheet* (order number 290701) and *Intel[®] Wireless Flash Memory (W30) Datasheet* (order number 290702) for information regarding flash read modes and operations.

9.0 Device Operation

9.1 Bus Operations

Bus operations for the W18/W30 SCSP family involve the following chip enable and output enable signals, respectively:

- F1-CE# for Flash Die#1 and F2-CE# for Flash Die#2
- F1-OE# for Flash Die#1 and F2-OE# for Flash Die#2

All other control signals are shared between the two flash die. [Table 1](#) to [Table 3](#) explain the bus operations of products across this SCSP family. Refer to the W18/W30 discrete datasheets (order numbers 290701 and 290702) for single flash die SCSP bus operations.

Table 1. Flash-Only Bus Operations

Device	Mode	F-RST#	F1-CE#	F1-OE#	F-WE#	ADV#	F-VPP	WAIT	F2-CE#	F2-OE#	D[15:0]	Notes
Flash Die#1	Sync Array Read	H	L	L	H	L	X	Active	H	X	Flash D _{OUT}	2, 3, 4
	All Async / Sync Non-Array Read	H	L	L	H	X	X	Asserted	H	X	Flash D _{OUT}	1, 3, 4, 5
	Write	H	L	H	L	X	V _{PPL} or V _{PPH}	Asserted	H	X	Flash D _{IN}	3, 4, 6
	Output Disable	H	L	H	H	X	X	Active	X	X	Flash High-Z	4
	Standby	H	H	X	X	X	X	High-Z	X	X	Flash High-Z	4
	Reset	L	X	X	X	X	X	High-Z	X	X	Flash High-Z	4

Device	Mode	F-RST#	F1-CE#	F1-OE#	F-WE#	ADV#	F-VPP	WAIT	F2-CE#	F2-OE#	D[15:0]	Notes
Flash Die#2	Sync Array Read	H	H	X	H	L	X	Active	L	L	Flash D _{OUT}	2, 3, 4
	All Async / Sync Non-Array Read	H	H	X	H	X	X	Asserted	L	L	Flash D _{OUT}	1, 3, 4, 5
	Write	H	H	X	L	X	V _{PPL} or V _{PPH}	Asserted	L	H	Flash D _{IN}	3, 4, 6
	Output Disable	H	X	X	H	X	X	Active	L	H	Flash High-Z	4
	Standby	H	X	X	X	X	X	High-Z	H	X	Flash High-Z	4
	Reset	L	X	X	X	X	X	High-Z	X	X	Flash High-Z	4

Notes:

- For asynchronous read operation, both die may be simultaneously selected, but may not simultaneously drive the memory bus. See Section 9.2, "Flash Command Definitions" on page 33 for details regarding flash selection overlap.
- WAIT is only valid during synchronous flash reads. WAIT is driven if F-CE# is asserted. Refer to the W18 or W30 datasheet (order number 290701 and 29702) for further information regarding WAIT Signal.
- For either flash die, F[2:1]-OE# and F-WE# should never be asserted simultaneously. If done so on a particular flash die, F[2:1]-OE# will override F-WE#.
- L means V_{IL} while H means V_{IH}. X can be V_{IL} or V_{IH} for inputs, V_{PPL}, V_{PPH} or V_{PPLK} for F-VPP.
- Flash CFI query and status register accesses use D[7:0] only, all other reads use D[15:0].
- Refer to W18/W30 datasheet for valid D_{IN} during flash writes.

Table 2. Flash + SRAM Bus Operations

Device	Mode	F-RST#	F[2:1]-CE#	F[2:1]-OE#	F-WE#	ADV#	F-VPP	WAIT	S-CS1#	S-CS2	R-OE#	R-WE#	R-UB#, R-LB#	D[15:0]	Notes
Flash Die(#1 or #2)	Sync Array Read	H	L	L	H	L	X	Active	SRAM must be in High-Z					Flash D _{OUT}	1, 2, 3, 5
	All Async/ Sync Non-array Read	H	L	L	H	X	X	Asserted						Flash D _{OUT}	1, 2, 3, 5, 6
	Write	H	L	H	L	L	V _{PPL} or V _{PPH}	Asserted						Flash D _{IN}	3, 7
	Output Disable	H	L	H	H	X	X	Active	Any SRAM mode allowed					Flash High-Z	5
	Standby	H	H	X	X	X	X	High-Z						Flash High-Z	5
	Reset	L	X	X	X	X	X	High-Z						Flash High-Z	5

Table 2. Flash + SRAM Bus Operations

Device	Mode	F-RST#	F[2:1]-CE#	F[2:1]-OE#	F-WE#	ADV#	F-VPP	WAIT	S-CS1#	S-CS2	R-OE#	R-WE#	R-UB#, R-LB#	D[15:0]	Notes	
SRAM	Read	Flash must be in High-Z								L	H	L	H	L	SRAM D _{OUT}	1, 4, 8, 2
	Write									L	H	X	L	L	SRAM D _{IN}	4, 5, 8, 2
	Output Disable									L	H	H	H	X	SRAM High-Z	5, 2
	Standby	Any flash mode allowed								H	X	X	X	X	SRAM High-Z	5, 8, 2
										X	L				SRAM High-Z	
Data Retention									Same as SRAM standby			SRAM High-Z	9, 2			

Notes:

- For asynchronous read operation, all die may be simultaneously selected, but may not simultaneously drive the memory bus.
- WAIT is only valid during synchronous flash reads. WAIT is driven if F-CE# is asserted.
- For flash die, F[2:1]-OE# and F-WE# should never be asserted simultaneously. If done so, F[2:1]-OE# will override F-WE#.
- For SRAM, R-OE# and R-WE# should never be asserted simultaneously.
- X can be V_{IL} or V_{IH} for inputs, V_{PPL}, V_{PPH} or V_{PPLK} for F-VPP.
- Flash CFI query and status register accesses use D[7:0] only, all other reads use D[15:0].
- Refer to W18 and W30 datasheet for valid D_{IN} during flash writes.
- The SRAM is enabled and/or disabled with the logical function: S-CS1# OR S-CS2.
- The SRAM can be placed into data retention mode by lowering S-VCC to the V_{DR} limit when in standby mode.

Table 3. Flash + PSRAM Bus Operations

Device	Mode	F-RST#	F[2:1]-CE#	F[2:1]-OE#	F-WE#	ADV#	F-VPP	WAIT	P-CS#	P-Mode	R-OE#	R-WE#	R-UB#, R-LB#	D[15:0]	Notes
Flash Die(#1 or #2)	Sync Array Read	H	L	L	H	L	X	Active	PSRAM must be in High-Z					Flash D _{OUT}	1, 2, 3, 4, 6
	All Async/ Sync Non-array Read	H	L	L	H	X	X	Asserted						Flash D _{OUT}	1, 2, 3, 4, 6, 7
	Write	H	L	H	L	X	V _{PPL} or V _{PPH}	Asserted						Flash D _{IN}	3, 4, 6, 8
	Output Disable	H	L	H	H	X	X	Active	Any PSRAM mode allowed					Flash High-Z	6
	Standby	H	H	X	X	X	X	High-Z						Flash High-Z	6
	Reset	L	X	X	X	X	X	High-Z						Flash High-Z	6

Table 3. Flash + PSRAM Bus Operations

Device	Mode	F-RST#	F[2:1]-CE#	F[2:1]-OE#	F-WE#	ADV#	F-VPP	WAIT	P-CS#	P-Mode	R-OE#	R-WE#	R-UB#, R-LB#	D[15:0]	Notes	
PSRAM	Read	Flash#1 and #2 must be in High-Z								L	H	L	H	L	PSRAM D _{OUT}	1, 5, 2
	Write	Flash#1 and #2 must be in High-Z								L	H	H	L	L	PSRAM D _{IN}	5, 2
	Output Disable	Any flash mode allowed								L	H	H	H	X	PSRAM High-Z	6, 2
	Standby	Any flash mode allowed								H	H	X	X	X	PSRAM High-Z	6, 2
	Deep Power-Down	Any flash mode allowed								H	L	X	X	X	PSRAM High-Z	6, 9, 2

Notes:

1. For asynchronous read operation, all die may be simultaneously selected, but may not simultaneously drive the memory bus. For synchronous burst-mode reads, only two die (one flash and the PSRAM) may be simultaneously selected.
2. WAIT is only valid during synchronous flash reads. WAIT is driven if F-CE# is asserted.
3. F1-CE# for Flash Die#1, F2-CE# for Flash Die#2. F1-OE# is for Flash Die#1, F2-OE# for Flash Die#2.
4. For either flash die, F[2:1]-OE# and F-WE# should never be asserted simultaneously. If done so on a particular flash die, F[2:1]-OE# will override F-WE#.
5. For PSRAM, R-OE# and R-WE# should never be asserted simultaneously.
6. X can be V_{IL} or V_{IH} for inputs, V_{PPL}, V_{PPH} or V_{PPLK} for F-VPP.
7. Flash CFI query and status register accesses use D[7:0] only, all other reads use D[15:0].
8. Refer to W30/W18 datasheet for Valid D_{IN} during flash writes.
9. Deep power-down is not applicable to 38F2020W0ZTQ1, 38F2020W0ZBQ1, 38F2030W0YTQ1, 38F2030W0YBQ1, 38F2030W0ZTQ2, 38F2030W0ZBQ2, 38F1030W0ZTQ0, 38F1030W0ZBQ0, 38F1030W0YTQE, 38F1030W0YBQE.

9.2 Flash Command Definitions

Refer to the discrete datasheets, Intel® Wireless Flash Memory (W18) Datasheet (order number 290701) and Intel® Wireless Flash Memory (W30) Datasheet (order number 290702) for information regarding flash command definitions.

10.0 Flash Read Operations

Refer to the *Intel[®] Wireless Flash Memory (W18) Datasheet* (order number 290701) and *Intel[®] Wireless Flash Memory (W30) Datasheet* (order number 290702) for information regarding flash read modes and operations.



11.0 Flash Program Operations

Refer to the *Intel[®] Wireless Flash Memory (W18) Datasheet* (order number 290701) and *Intel[®] Wireless Flash Memory (W30) Datasheet* (order number 290702) for information regarding flash read modes and operations.

12.0 Flash Erase Operations

Refer to the *Intel^E Wireless Flash Memory (W18) Datasheet* (order number 290701) and *Intel^E Wireless Flash Memory (W30) Datasheet* (order number 290702) for information regarding flash read modes and operations.

13.0 Flash Security Modes

Refer to the *Intel[®] Wireless Flash Memory (W18) Datasheet* (order number 290701) and *Intel[®] Wireless Flash Memory (W30) Datasheet* (order number 290702) for information regarding flash read modes and operations.

14.0 Flash Read Configuration Register

Refer to the *Intel[®] Wireless Flash Memory (W18) Datasheet* (order number 290701) and *Intel[®] Wireless Flash Memory (W30) Datasheet* (order number 290702) for information regarding flash read modes and operations.

15.0 SRAM Operations

15.1 Power-up Sequence and Initialization

The SRAM functionality and reliability are independent of the power-up sequence and power-up slew rate of the core $S-V_{CC}$. Any power-up sequence and power-up slew rate is possible under use conditions. SRAM reliability is also independent of the power-down sequence and power-down slew rate of the core $S-V_{CC}$.

15.2 Data Retention Mode

Table 1. SRAM Data Retention Operation

Symbol	Parameter	Min	Max	Unit	Notes
t_{SDR}	Data Retention Set-up Time	0	–	ns	
t_{RDR}	Data Retention Recovery Time	t_{RC}	–	ns	1

Note:

- t_{RC} is defined in Table 7.2, “SRAM AC Characteristics” on page 24.

Figure 1. SRAM Data Retention Operation Waveform—S-CS1# Controlled

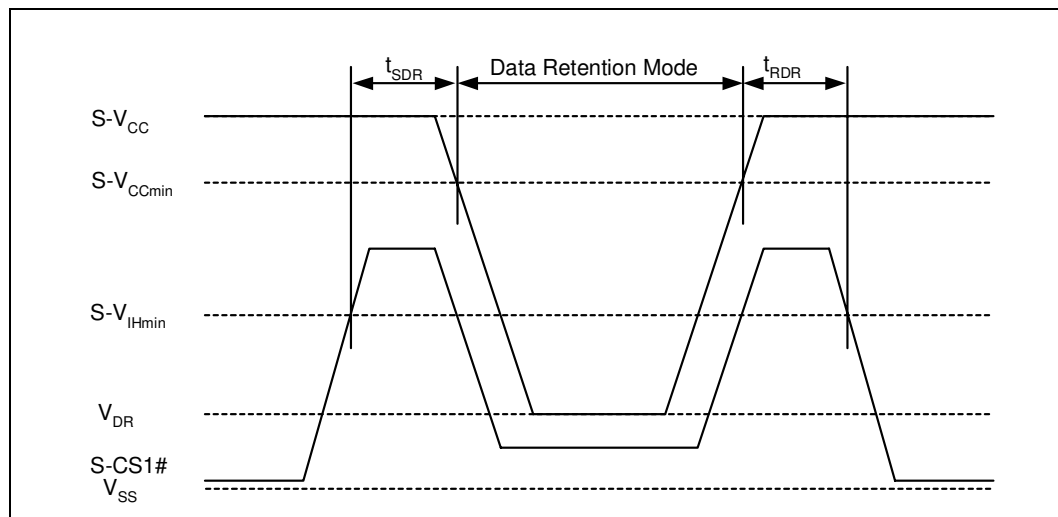
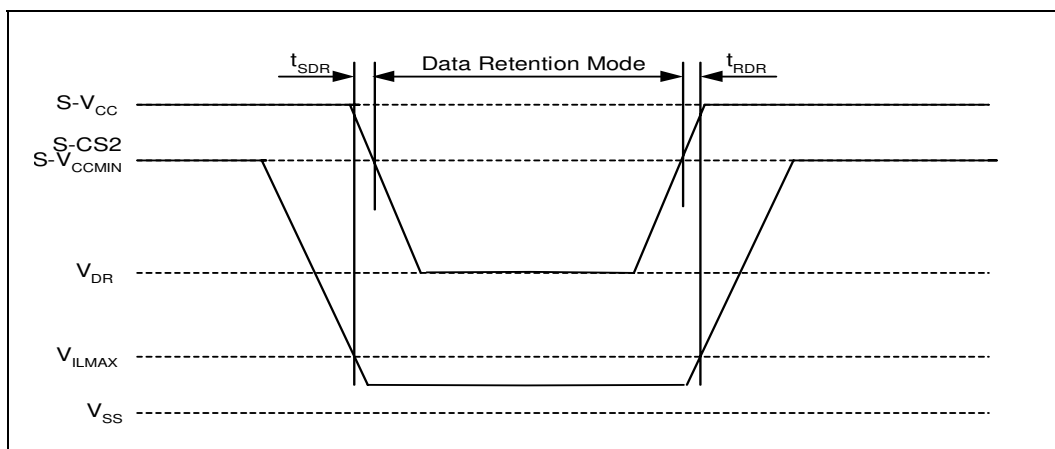

Figure 2. SRAM Data Retention Operation Waveform—S-CS2 Controlled



16.0 PSRAM Operations

16.1 Power-Up Sequence and Initialization

The PSRAM functionality and reliability are independent of the power-up sequence and slew rate of the core P-V_{CC}. Any power-up sequence and slew rate is possible under use conditions. PSRAM reliability are also independent of the power-down sequence and slew rate of the core P-V_{CC}.

The following power-up sequence and register setting should be used before starting normal operation. The PSRAM power-up sequence is represented in Figure 1. Following power application, make P-Mode high after fixing P-Mode to a low level for a period of t_{I1}. Make P-CS# high before making P-Mode high. P-CS# and P-Mode are fixed to a high level for period of t_{I3}.

Once the power-up sequence is complete, be sure to set the register, before starting any normal operation. The register is set by a five-cycle operation. The process involves first performing a dummy read immediately followed by two continuous reads of the address 0x1FFFFFF then successively writing two specific data. See the flowchart in Figure 2, which illustrates the process of setting the register. Note that P-CS# must be toggling to high for a minimum of 10 ns between each read or write.

Figure 1. Timing Waveform for Power-Up Sequence

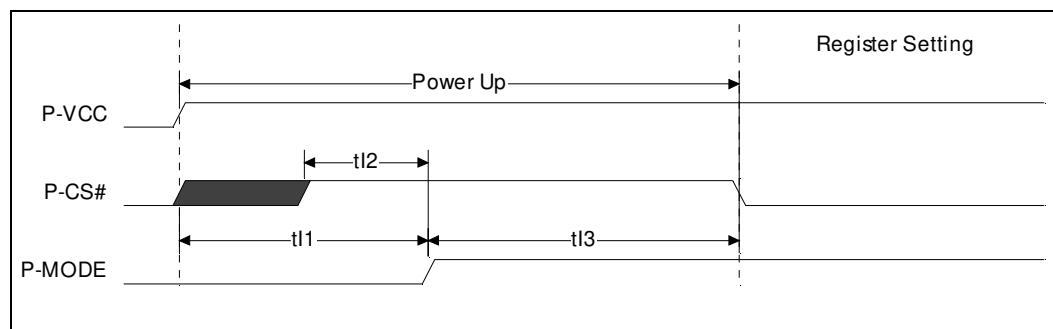

Table 1. Power-Up Sequence Specifications

Parameter	Description	Min	Max	Unit	Notes
t _{I1}	Power application with P-Mode held low	50	—	μs	1,2,3
t _{I2}	P-CS# high to P-Mode high	10	—	ns	
t _{I3}	P-Mode high to P-CS# low	500	—	μs	

Notes:

1. Toggle P-Mode to low when starting the power-up sequence.
2. t_{I1} is specified from when the power supply voltage reaches V_{CCMIN}.
3. Does not apply to 38F2020W0ZTQ1, 38F2020W0ZBQ1, 38F2030W0YTQ1, 38F2030W0YBQ1, 38F2030W0ZTQ2, and 38F2030W0ZBQ2, 38F1030W0ZTQ0, 38F1030W0ZBQ0, 38F1030W0YTQE, 38F1030W0YBQE line items. Valid PSRAM operations for these line items can begin 200 μs after P-Vcc has reached P-Vcc min.

Figure 2. PSRAM Register Setting Flowchart at Initialization

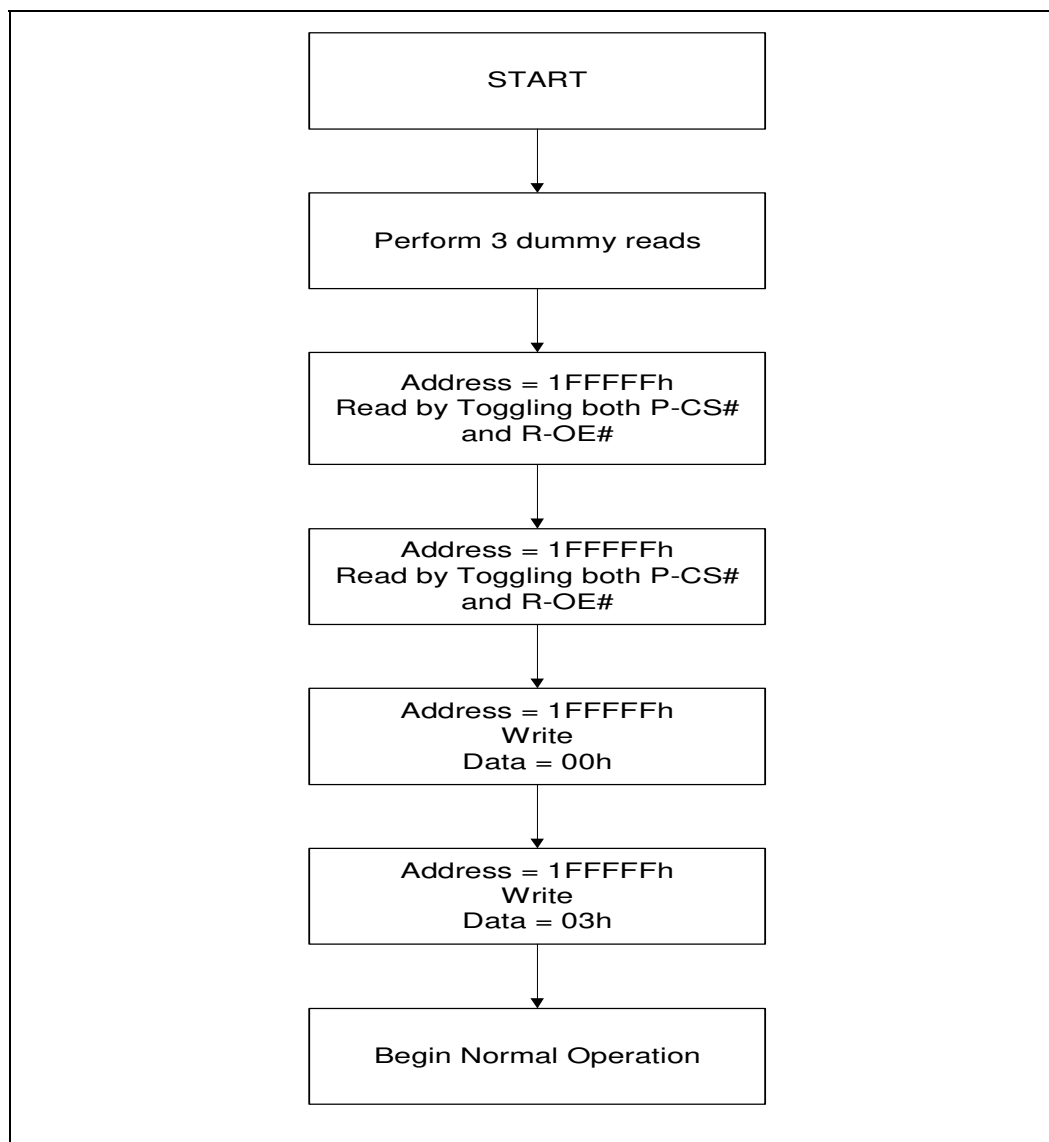

16.2 Standby Mode/ Deep Power-Down Mode

Caution:

38F2020W0ZTQ1, 38F2020W0ZBQ1, 38F2030W0YTQ1, 38F2030W0YBQ1,
38F2030W0ZTQ2, 38F2030W0ZBQ2, 38F1030W0ZTQ0, 38F1030W0ZBQ0,
38F1030W0YTQE, 38F1030W0YBQE line items do not have the deep power-down feature.

Data is lost during deep power-down mode as shown in the Table below. Wake-up from deep power-down mode involves the same initialization sequence as discussed in [Section 16.1, “Power-Up Sequence and Initialization”](#) on page 41.

Mode	Memory Cell Data	Delay time to go Active
Standby	Valid	0 ns
Deep Power-Down	Invalid	Start-Up Sequence

Figure 3. Timing Waveform for Entering Deep Power-Down Mode

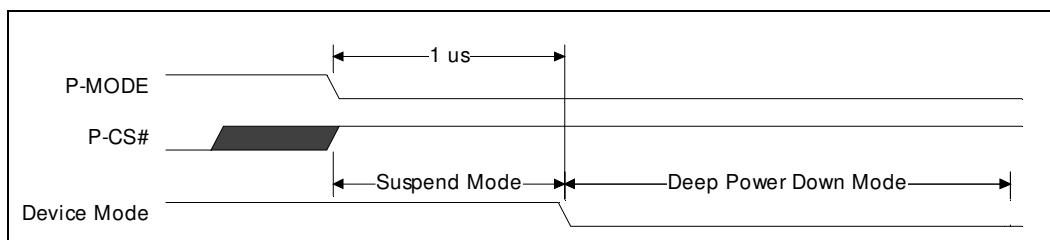

16.3 PSRAM Special Read and Write Constraints

Caution: This section does not apply to 38F2020W0ZTQ1, 38F2020W0ZBQ1, 38F2030W0YTQ1, 38F2030W0YBQ1, 38F2030W0ZTQ2, 38F2030W0ZBQ2, 38F1030W0ZTQ0, 38F1030W0ZBQ0, 38F1030W0YTQE, 38F1030W0YBQE line items.

Table 2. PSRAM Special Read Constraints

Description	Min	Max	Unit	Notes
Cannot have sub t_{RC} address toggle for more than 4 μ s in active mode. Need either a read operation or P-CS# high for t_{RC} in that time frame	N/A	N/A	–	
P-CS# high level pulse width	10	–	ns	1
R-UB#/R-LB# high level pulse width	10	–	ns	1
R-OE# high level pulse width in active mode (P-CS# low)	10	10,000	ns	
P-CS# low to R-OE# low	–	10,000	ns	
Address Skew time (unstable address with P-CS# low)	–	10	ns	2

Notes:

1. Toggling of these control signals is not necessary during address controlled read operations.
2. Address skew time (t_{SKEW}) indicates the following three types of time depending on the condition.
 - a. When switching P-CS# from high to low, t_{SKEW} is the time from the P-CS# low input point until the next address is determined.
 - b. When switching P-CS# from low to high, t_{SKEW} is the time from the address change start point to the P-CS# high input point.
 - c. When P-CS# is fixed to low, t_{SKEW} is the time from the address start point until the next address is determined.

Since specs are defined for t_{SKEW} only when P-CS# is active, t_{SKEW} is not subject to limitations when P-CS# is switched from high to low following address determination, or when the address is changed after P-CS# is switched from low to high.

Table 3. PSRAM Special Write Constraints

Description	Min	Max	Unit	Notes
Need either R-WE# high or P-CS# high for at least t_{WC} time, for every 4us window during write operations.	N/A	N/A	–	
R-OE# high to R-WE# low in active mode (P-CS# low)	0	10,000	ns	
R-WE# high to R-OE# low in active mode (P-CS# low)	10	10,000	ns	
Address Skew time (unstable address with P-CS# low)	–	10	ns	1

Note:

1. Address skew time (t_{SKEW}) indicates the following three types of time depending on the condition.
 - a. When switching P-CS# from high to low, t_{SKEW} is the time from the P-CS# low input point until the next address is determined.
 - b. When switching P-CS# from low to high, t_{SKEW} is the time from the address change start point to the P-CS# high input point.
 - c. When P-CS# is fixed to low, t_{SKEW} is the time from the address start point until the next address is determined.

Since specs are defined for t_{SKEW} only when P-CS# is active, t_{SKEW} is not subject to limitations when P-CS# is switched from high to low following address determination, or when the address is changed after P-CS# is switched from low to high.



Appendix A Write State Machine

Refer to the *Intel^E Wireless Flash Memory (W18) Datasheet* (order number 290701) and *Intel^E Wireless Flash Memory (W30) Datasheet* (order number 290702) for the WSM details.



Appendix B Common Flash Interface

Refer to the *Intel[®] Wireless Flash Memory (W18) Datasheet* (order number 290701) and *Intel[®] Wireless Flash Memory (W30) Datasheet* (order number 290702) for the CFI details.



Appendix C Flash Flowcharts

Refer to the *Intel^E Wireless Flash Memory (W18) Datasheet* (order number 290701) and *Intel^E Wireless Flash Memory (W30) Datasheet* (order number 290702) for the flash flowchart details.



Appendix D Additional Information

Order Number	Document
290701	<i>1.8 Volt Intel® Wireless Flash Memory (W18) Datasheet</i>
290702	<i>1.8 Volt Intel® Wireless Flash Memory with 3 Volt I/O (W30) Datasheet</i>
251216	<i>64-Mbit 1.8 Volt Intel® Wireless Flash Memory SCSP Family Application Note</i>

Notes:

1. Please call the Intel Literature Center at (800) 548-4725 to request Intel documentation. International customers should contact their local Intel or distribution sales office.
2. For the most current information on Intel® Flash memory products, software and tools, visit our website at <http://developer.intel.com/design/flash>.

Appendix E Ordering Information

Figure 1 shows the decoder for products in this SCSP family with both flash and RAM. Figure 2 shows the decoder for products in this SCSP family with flash die only (no RAM). Table 3, “32WQ and 64WQ W18/W30 SCSP Ordering Information (Flash + PSRAM)” on page 52 lists available product combinations.

Figure 1. Decoder for Flash + RAM SCSP Family Devices

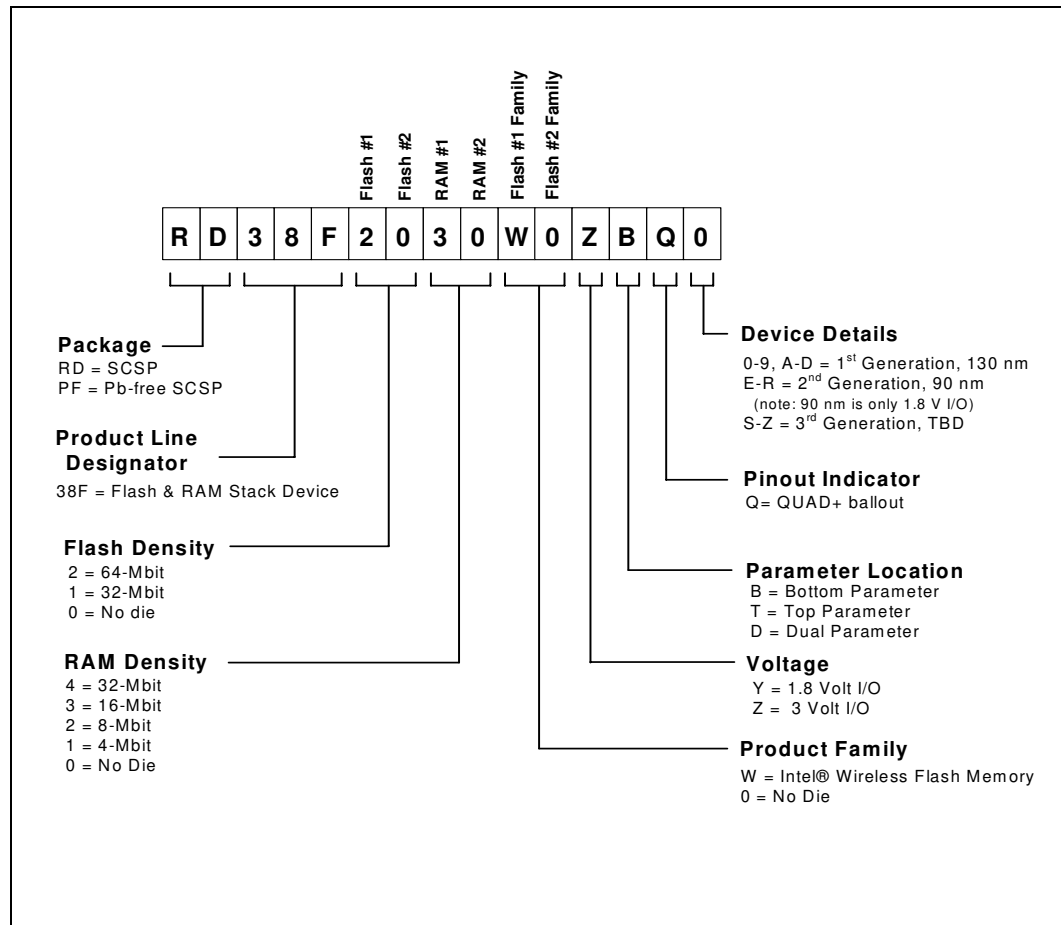

Figure 2. Decoder for Flash-Only SCSP Family Devices

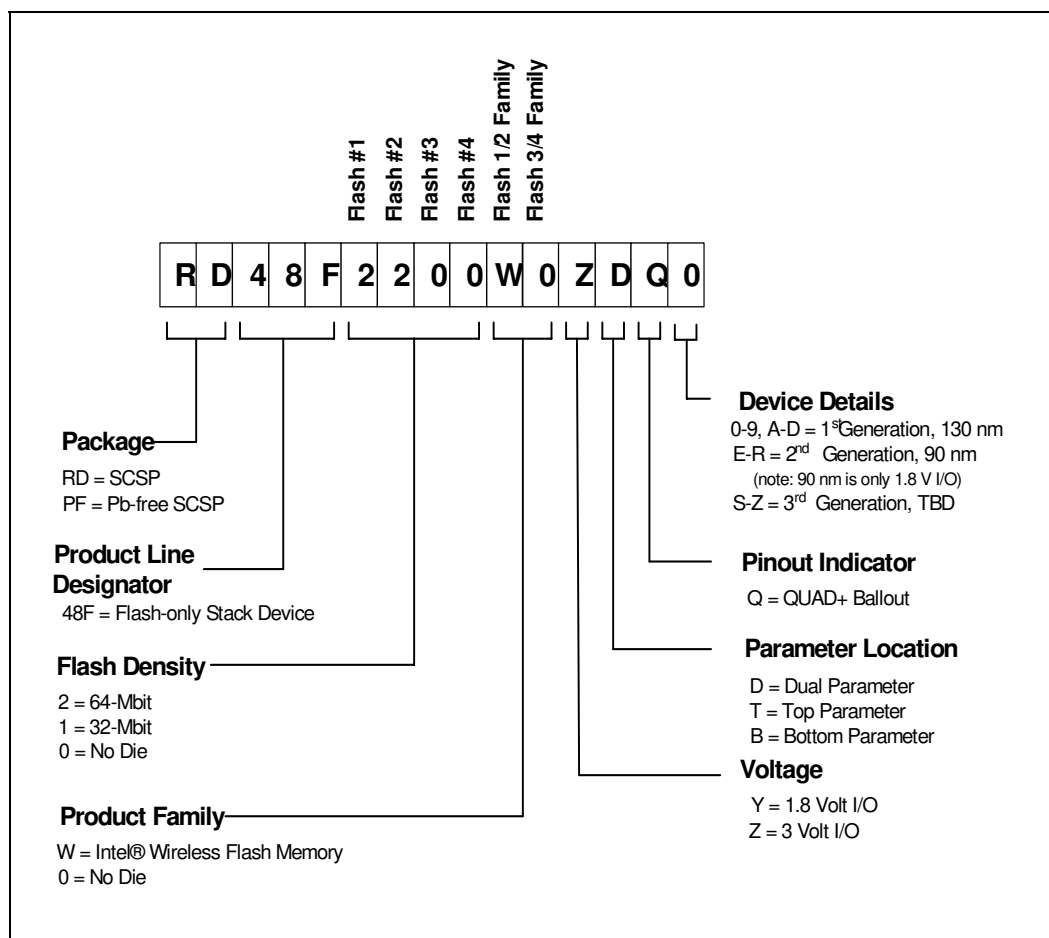

Table 1. 32WQ and 64WQ W18/W30 SCSP Ordering Information (Flash Only)

Flash Component	Package			Product Number (1,2,3,4,5)
	Size (mm)	Type	Ballout	
32 W30	8 x 10 x 1.2	Lead-free	Quad +	PF48F1000W0ZTQ0 PF48F1000W0ZBQ0
64 W30	8 x 10 x 1.2	Lead-free	Quad +	PF48F2000W0ZTQ0 PF48F2000W0ZBQ0
64 W18 + 32 W18	8 x 10 x 1.2	Leaded	Quad +	RD48F2100W0YDQE
64 W18 + 64W18	8 x 10 x 1.2	Leaded	Quad +	RD48F2200W0YDQ0

Notes:



1. W18 = Intel® Wireless Flash Memory (W18) with 1.8 V I/O; W30 = Intel® Wireless Flash Memory (W30) with 3.0 V I/O.
2. B = Bottom Parameter, where Flash Die #1, F1-CE# = Bottom Parameter and Flash Die #2, F2-CE# = Top Parameter.
3. T = Top Parameter where Flash Die #1, F1-CE# = Top Parameter and Flash Die #2, F2-CE# = Bottom Parameter.
4. D = Dual Parameter where Flash Die #1, F1-CE# = Bottom Parameter and Flash Die #2, F2-CE# = Top Parameter.
5. Parts ending with "QE" are 90 nm Flash devices.

Table 2. 32WQ and 64WQ W18/W30 SCSP Ordering Information (Flash + SRAM)

Flash Component	RAM	Package			Product Number ^(1,2,3,4)
		Size in Mbit and Family	Size in Mbit and Type	Size (mm)	
64 W18	4 SRAM	8 x 10 x 1.2	Leaded	Quad+	RD38F2010W0YTQ0 RD38F2010W0YBQ0
	8 SRAM	8 x 10 x 1.2	Leaded	Quad+	RD38F2020W0YTQ0 RD38F2020W0YBQ0
	16 SRAM	8 x 10 x 1.2	Leaded	Quad+	RD38F2030W0YTQ0 RD38F2030W0YBQ0
64 W30	8 SRAM	8 x 10 x 1.2	Leaded	Quad+	RD38F2020W0ZTQ0 RD38F2020W0ZBQ0
	16 SRAM	8 x 10 x 1.2	Leaded	Quad+	RD38F2030W0ZTQ0 RD38F2030W0ZBQ0
64 W18 + 64 W18	16 SRAM	8 x 10 x 1.4	Leaded	Quad+	RD38F2230WWYDQ0
64 W30 + 64 W30	16 SRAM	8 x 10 x 1.4	Leaded	Quad+	RD38F2230WWZDQ0

Notes:

1. W18 = Intel® Wireless Flash Memory (W18) with 1.8 V I/O; W30 = Intel® Wireless Flash Memory (W30) with 3.0 V I/O.
2. B = Bottom Parameter, where Flash Die #1, F1-CE# = Bottom Parameter and Flash Die #2, F2-CE# = Top Parameter.
3. T = Top Parameter where Flash Die #1, F1-CE# = Top Parameter and Flash Die #2, F2-CE# = Bottom Parameter.
4. D = Dual Parameter where Flash Die #1, F1-CE# = Bottom Parameter and Flash Die #2, F2-CE# = Top Parameter.

Table 3. 32WQ and 64WQ W18/W30 SCSP Ordering Information (Flash + PSRAM)

Flash Component	RAM	Package			Product Number (1,2,3,4,5)	PSRAM used
		Size (mm)	Ballout	Type		
32 W18	16 PSRAM	8 x 10 x 1.2	Quad+	Lead-free	PF38F1030W0YTQE PF38F1030W0YBQE	70 ns, No PMODE pin
32 W30	16 PSRAM	8 x 10 x 1.2	Quad+	Leaded	RD38F1030W0ZTQ0 RD38F1030W0ZBQ0	70 ns, No PMODE pin
				Lead-free	PF38F1030W0ZTQ0 PF38F1030W0ZBQ0	70 ns, No PMODE pin
64 W18	16 PSRAM	8 x 10 x 1.2	Quad+	Leaded	RD38F2030W0YTQ1 RD38F2030W0YBQ1	70 ns, No PMODE pin
				Lead-free	PF38F2030W0YTQ1 PF38F2030W0YBQ1	
				Leaded	RD38F2030W0YTQE RD38F2030W0YBQE	
				Lead-free	PF38F2030W0YTQE PF38F2030W0YBQE	
64 W30	16 PSRAM	8 x 10 x 1.2	Quad+	Leaded	RD38F2030W0ZTQ1 RD38F2030W0ZBQ1	85 ns, with PMODE pin
				Leaded	RD38F2030W0ZTQ2 RD38F2030W0ZBQ2	70 ns, No PMODE pin
				Lead-free	PF38F2030W0ZTQ2 PF38F2030W0ZBQ2	
64 W18	32 PSRAM	8 x 10 x 1.2	QUAD+	Leaded	RD38F2040W0YTQ0 RD38F2040W0YBQ0	88 ns, with PMODE pin
				Lead-free	PF38F2040W0YTQ0 PF38F2040W0YBQ0	
64 W30	32 PSRAM	8 x 10 x 1.2	QUAD+	Leaded	RD38F2040W0ZTQ0 RD38F2040W0ZBQ0	85 ns, No PMODE pin
64 W18 + 64 W18	32 PSRAM	8 x 10 x 1.4	QUAD+	Leaded	RD38F2240WWYDQ0 ⁽⁶⁾ RD38F2240WWYDQ1	88 ns, with PMODE pin
64 W30 + 64 W30	32 PSRAM	8 x 10 x 1.4	QUAD+	Leaded	RD38F2240WWZDQ0	85 ns, No PMODE pin

Notes:

- W18 = Intel® Wireless Flash Memory (W18) with 1.8 V I/O; W30 = Intel® Wireless Flash Memory (W30) with 3.0 V I/O.
- B = Bottom Parameter, where Flash Die #1, F1-CE# = Bottom Parameter and Flash Die #2, F2-CE# = Top Parameter.
- T = Top Parameter where Flash Die #1, F1-CE# = Top Parameter and Flash Die #2, F2-CE# = Bottom Parameter.
- D = Dual Parameter where Flash Die #1, F1-CE# = Bottom Parameter and Flash Die #2, F2-CE# = Top Parameter.
- Parts ending with "QE" are 90 nm Flash devices.
- RD38F2240WWYDQ0 = Engineering Samples; RD38F2240WWYDQ1 = Production