

Industrial drive system kit based on ACEPACK 2 power module



Features

- A2C35S12M3-F ACEPACK™ 2 power module in converter inverter brake (CIB) topology
- Control stage based on STM32F303 ARM® Cortex®-M4 MCU and compatible with ST MC library with ST-FOC algorithm (sensored and sensorless mode)
- In-rush current, thermal and overcurrent protection
- Brake function with external resistor
- On-board isolated current sensing of 2.1 kV_{RMS}
- Galvanically isolated driving stage with STGAP1AS
- Additional gate driving for dissipative brake section (external power resistor)
- Protections and sensing (overvoltage, overcurrent, overtemperature, current reading input)
- Input/output interface (analog/digital)
- RoHS compliant
- WEEE compliant

Description

The [STEVAL-HK001V2](#) is an industrial drive evaluation system designed to demonstrate the capabilities of the [A2C35S12M3-F](#) IGBT power module for motor control applications.

It offers a solution for single- or three-phase main input with a converter inverter brake (CIB) topology able to handle a motor current up to 35 A (power module maximum current rating).

The hardware platform is a stackable solution consisting of: a power stage (STEVAL-CTM002V2), which contains the power module and current sensing circuitry, a driving stage (STEVAL-CTM001V2D) which contains the new galvanically isolated STGAP1AS gapDRIVE, with suitable circuitry to drive the embedded IGBTs in the power module, a control board (STEVAL-CTM001V1C), based on the STM32F303RBT7 microcontroller, which is able to execute the field oriented control (FOC) algorithm to obtain the best performance in all motor control applications.

The control board has RS232 and CAN external interfaces to let you monitor and control your application on the evaluation system via PC.

Product summary	
Industrial drive system kit based on ACEPACK™ 2 power module	STEVAL-HKI001V2
35 A 1200 V converter inverter brake ACEPACK™ 2 IGBT power module	A2C35S12M3-F
Mainstream mixed signal MCUs ARM® Cortex®-M4 core with DSP and FPU	STM32F303RBT7
Automotive galvanically isolated single gate driver	STGAP1AS

1 Schematic diagrams

Figure 1. STEVAL-CTM001V2D schematic circuit (1 of 13)

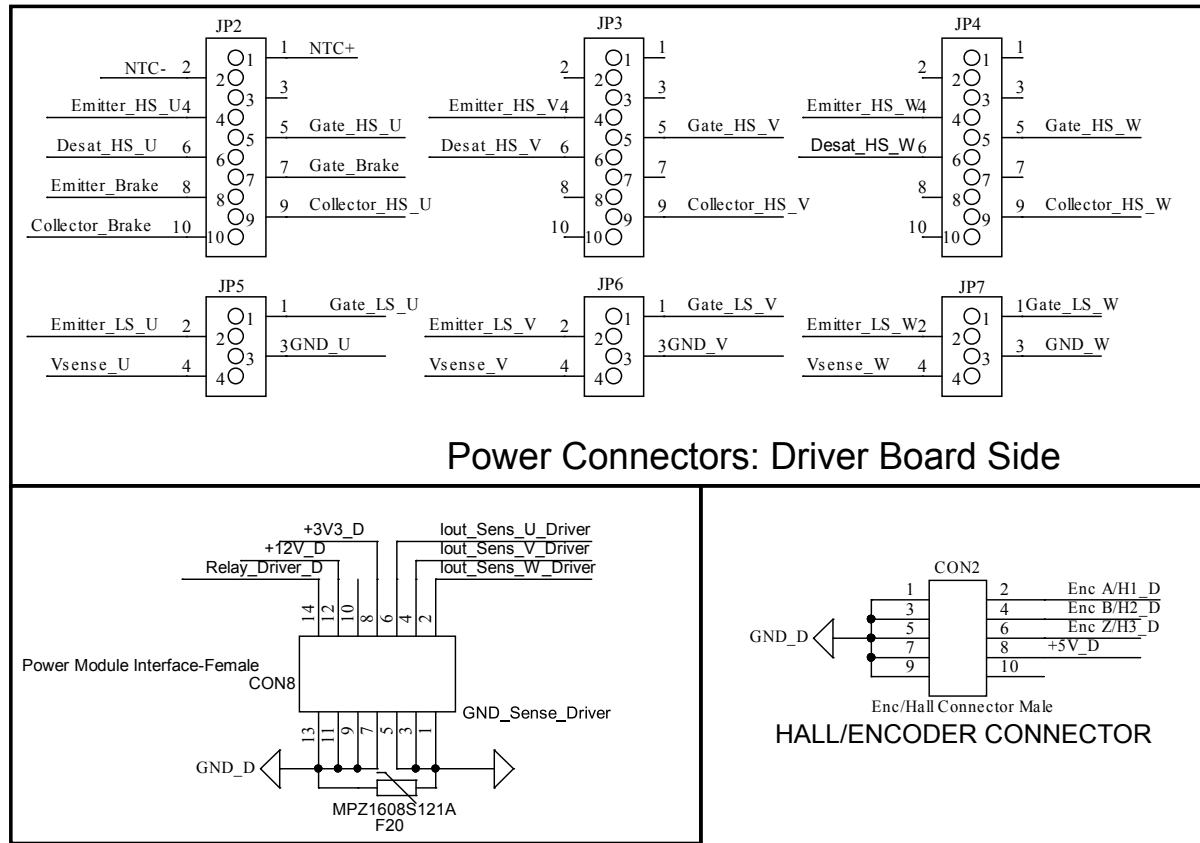

Figure 2. STEVAL-CTM001V2D schematic circuit (2 of 13)

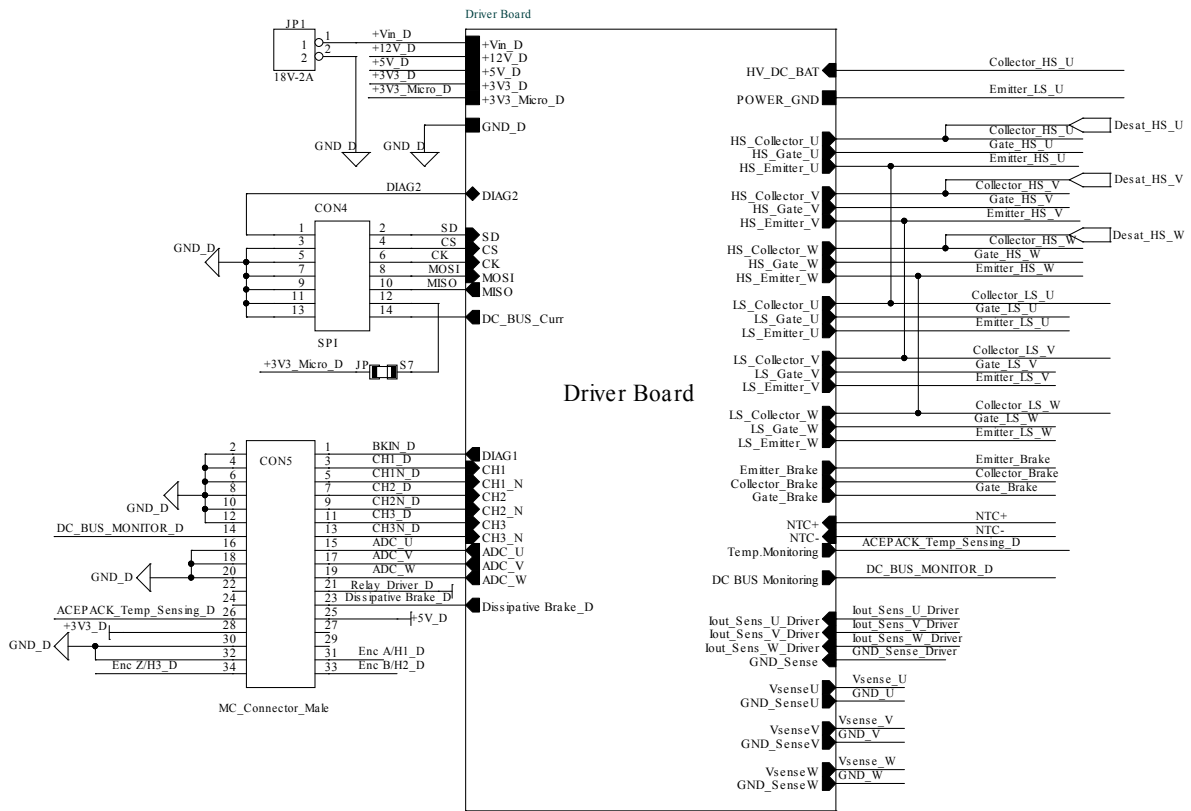

Figure 3. STEVAL-CTM001V2D schematic circuit (3 of 13)

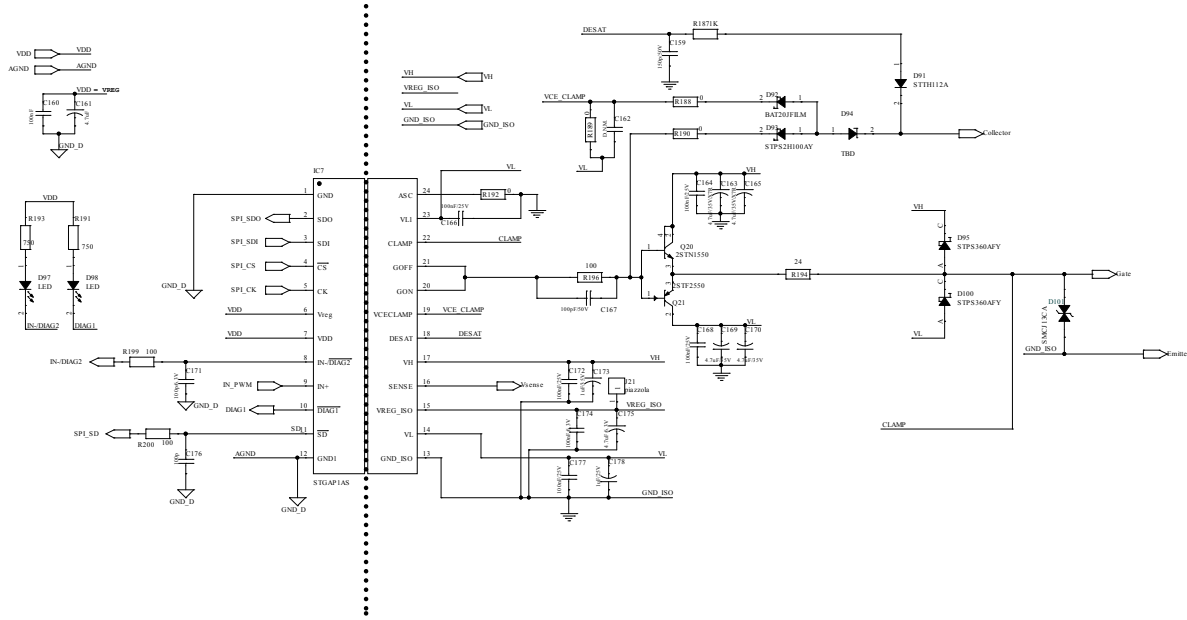

Figure 4. STEVAL-CTM001V2D schematic circuit (4 of 13)

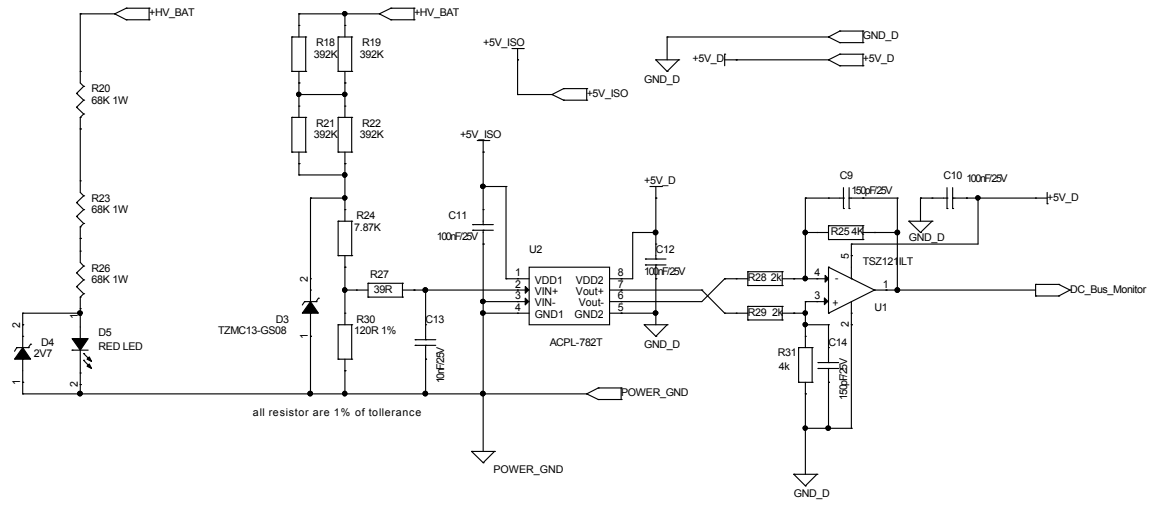

Figure 5. STEVAL-CTM001V2D circuit schematic (5 of 13)

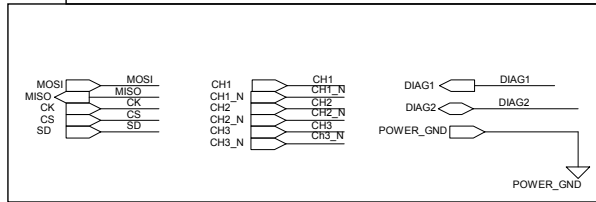
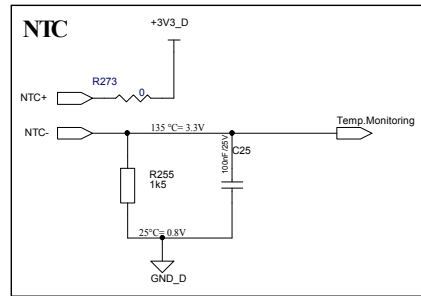
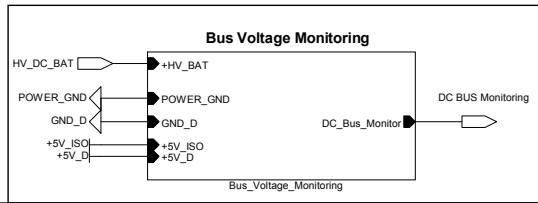
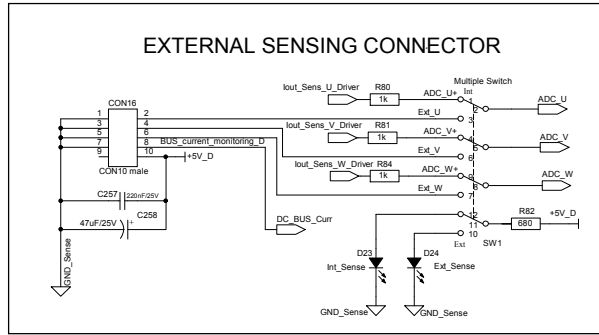
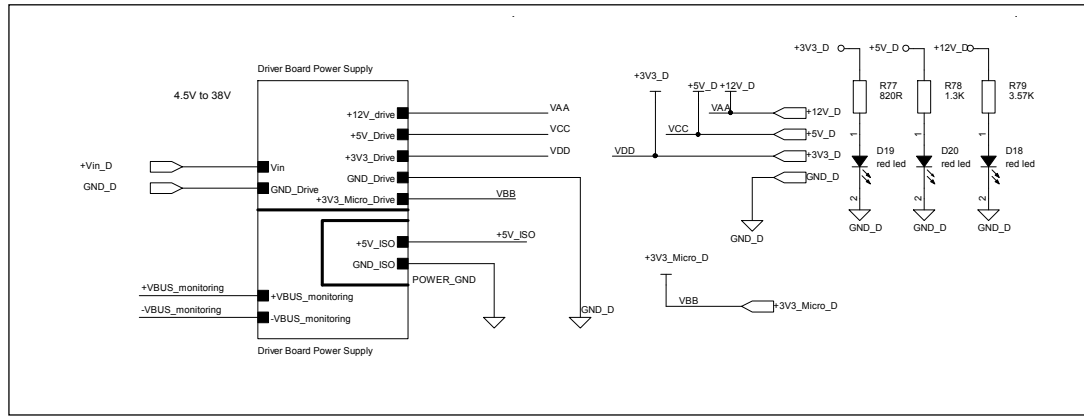

Figure 6. STEVAL-CTM001V2D circuit schematic (6 of 13)

DC/DC Isolated for Driving Section

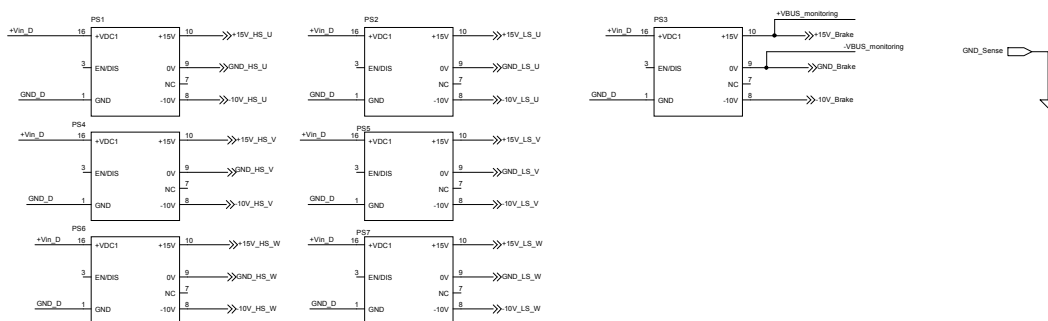

Figure 7. STEVAL-CTM001V2D circuit schematic (7 of 13)

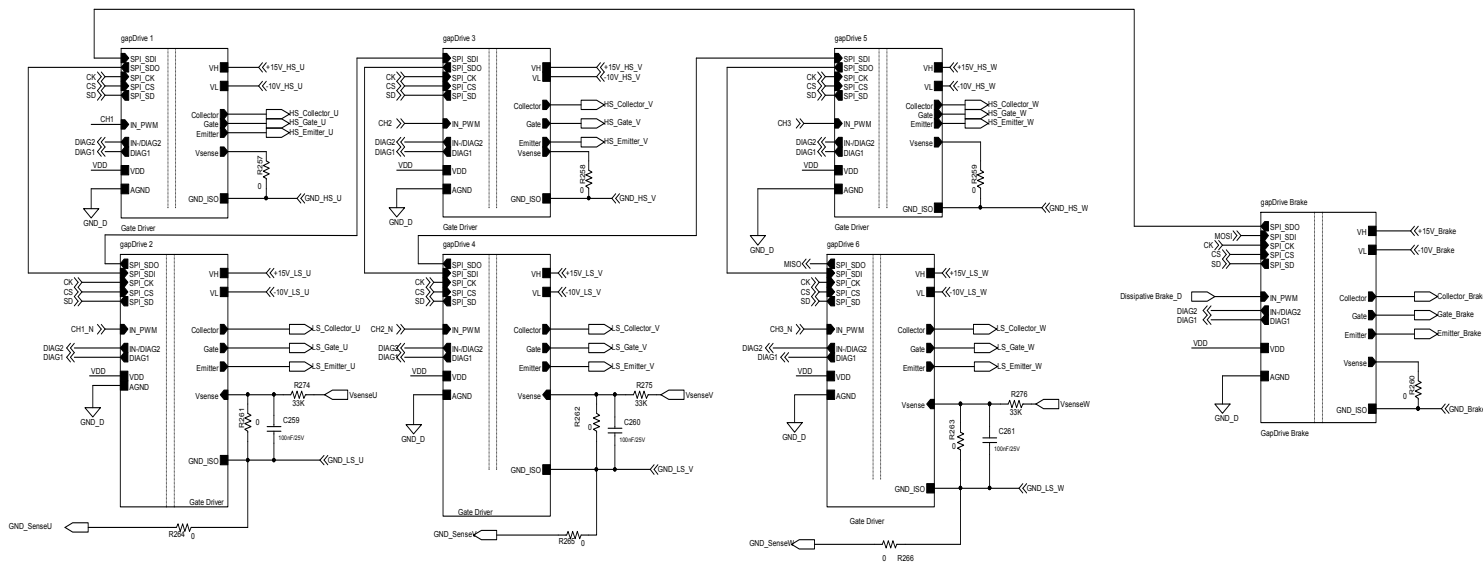

Figure 8. STEVAL-CTM001V2D circuit schematic (8 of 13)

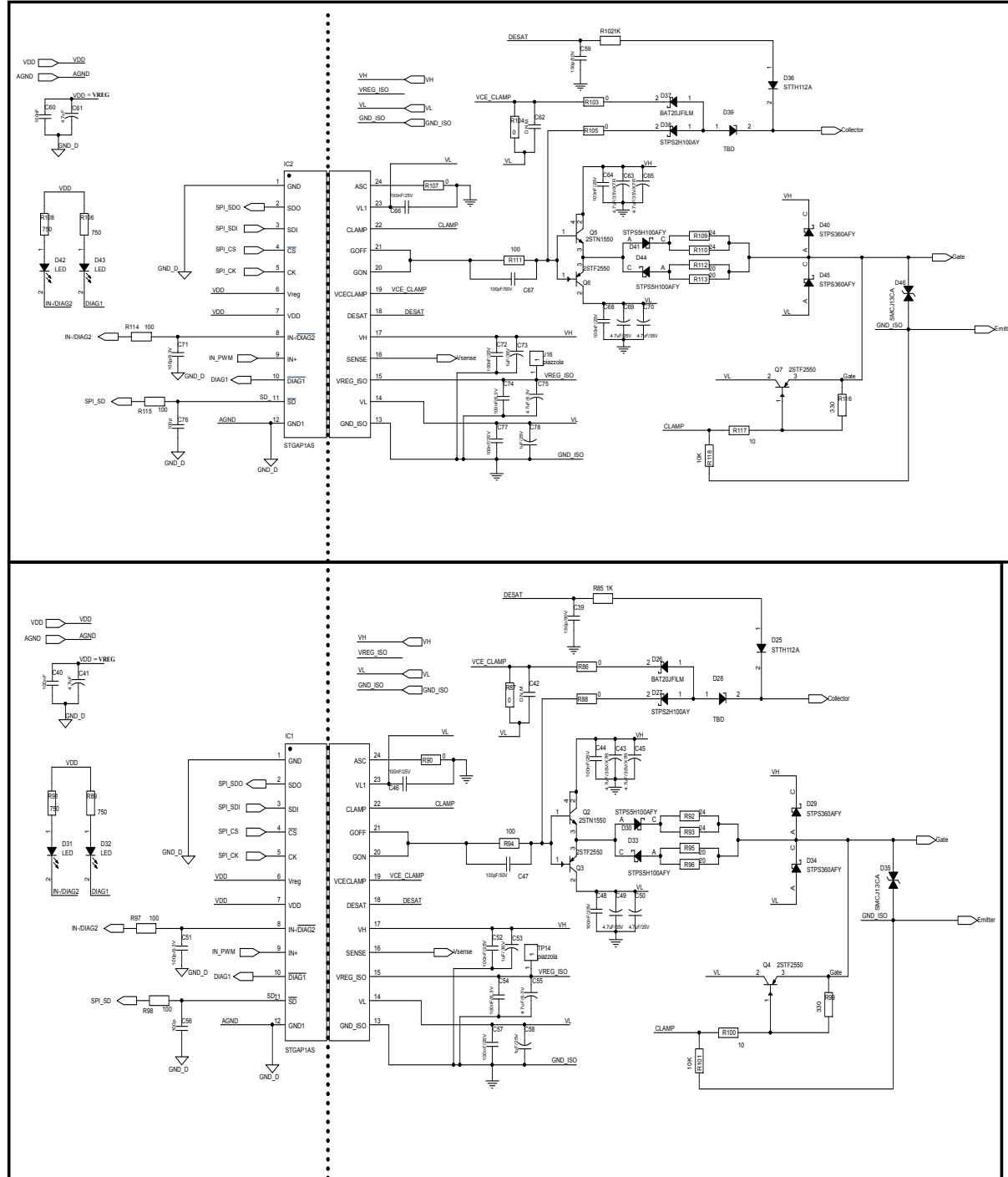

Figure 9. STEVAL-CTM001V2D circuit schematic (9 of 13)

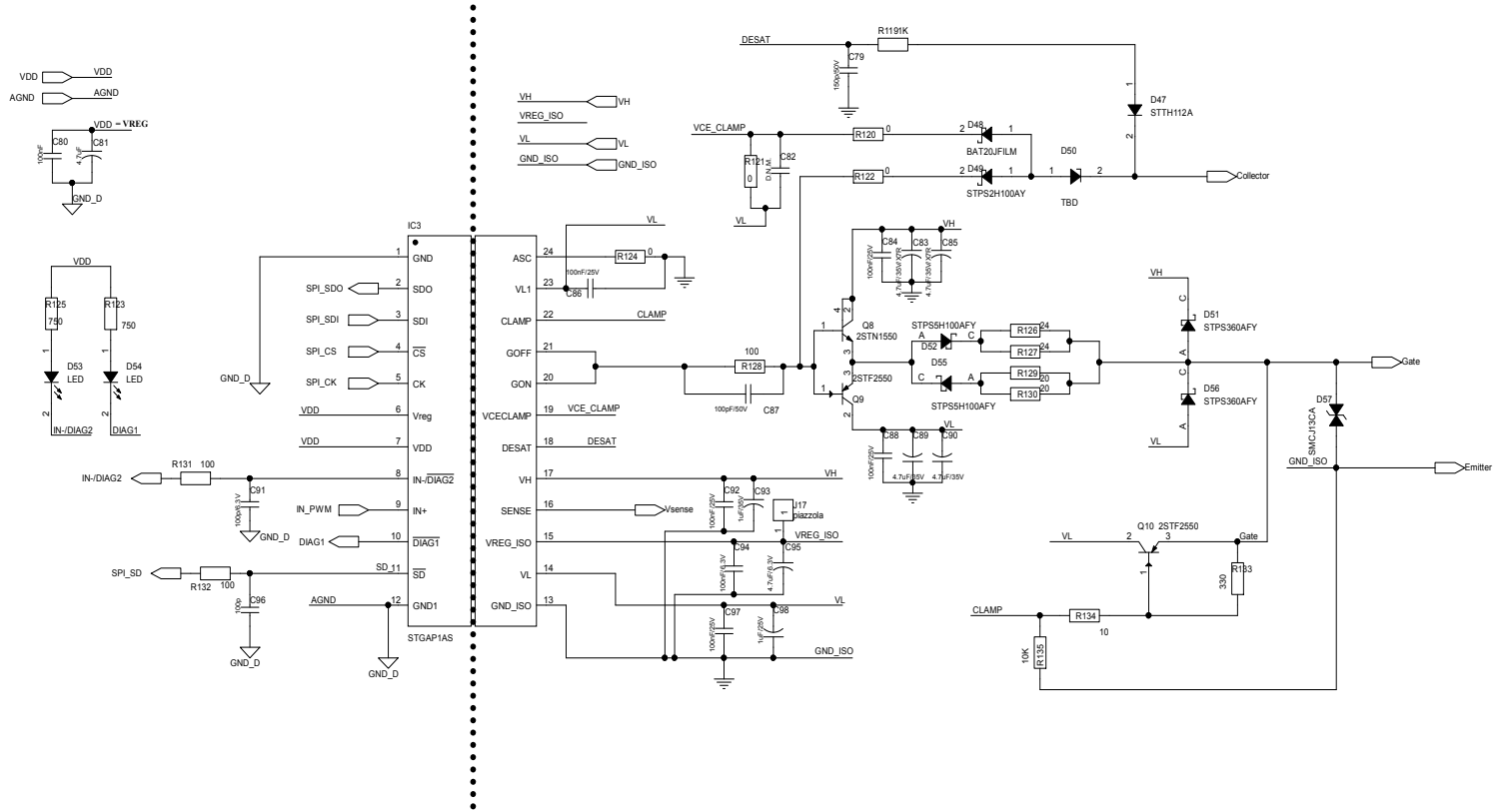

Figure 10. STEVAL-CTM001V2D circuit schematic (10 of 13)

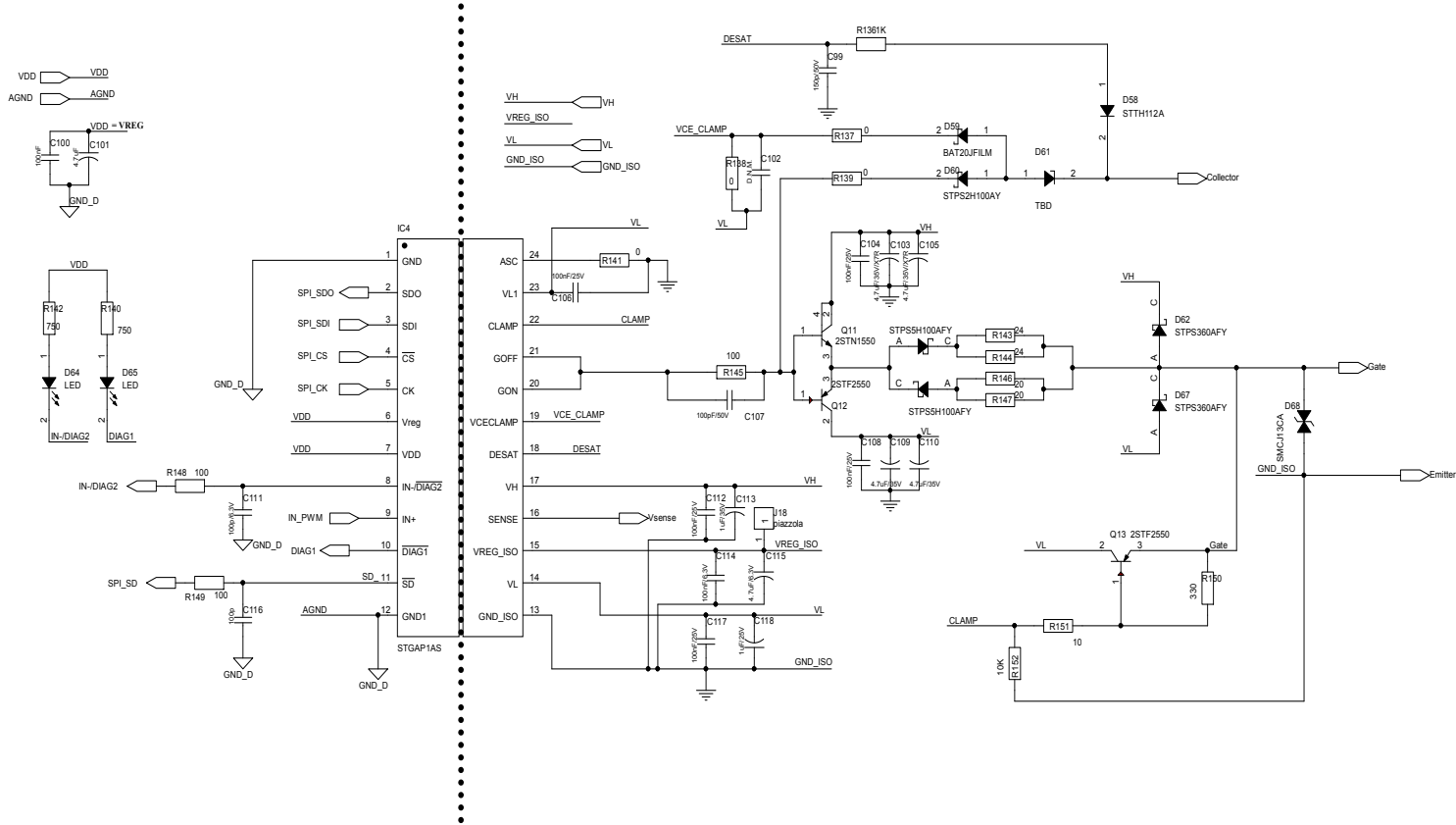

Figure 11. STEVAL-CTM001V2D circuit schematic (11 of 13)

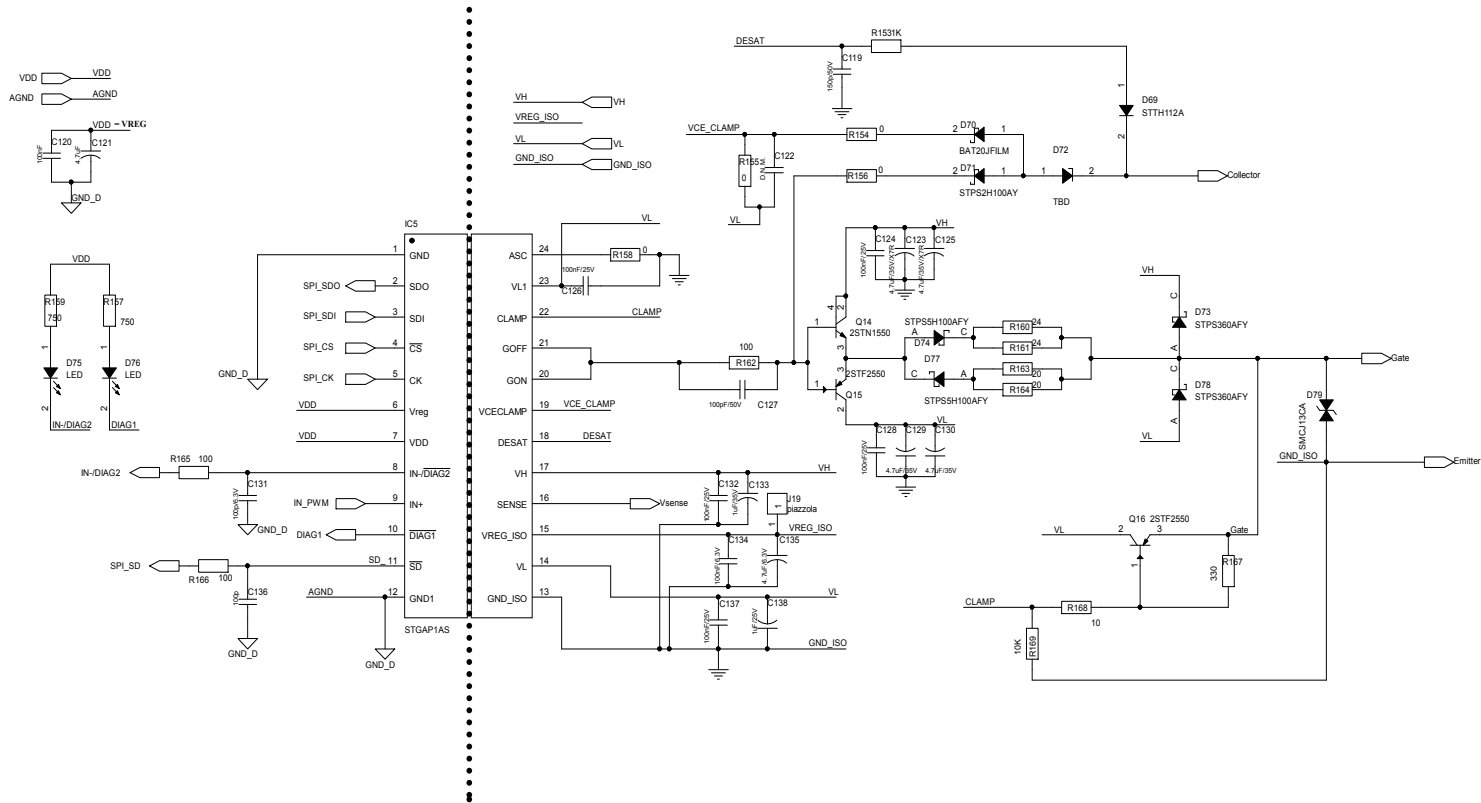

Figure 12. STEVAL-CTM001V2D circuit schematic (12 of 13)

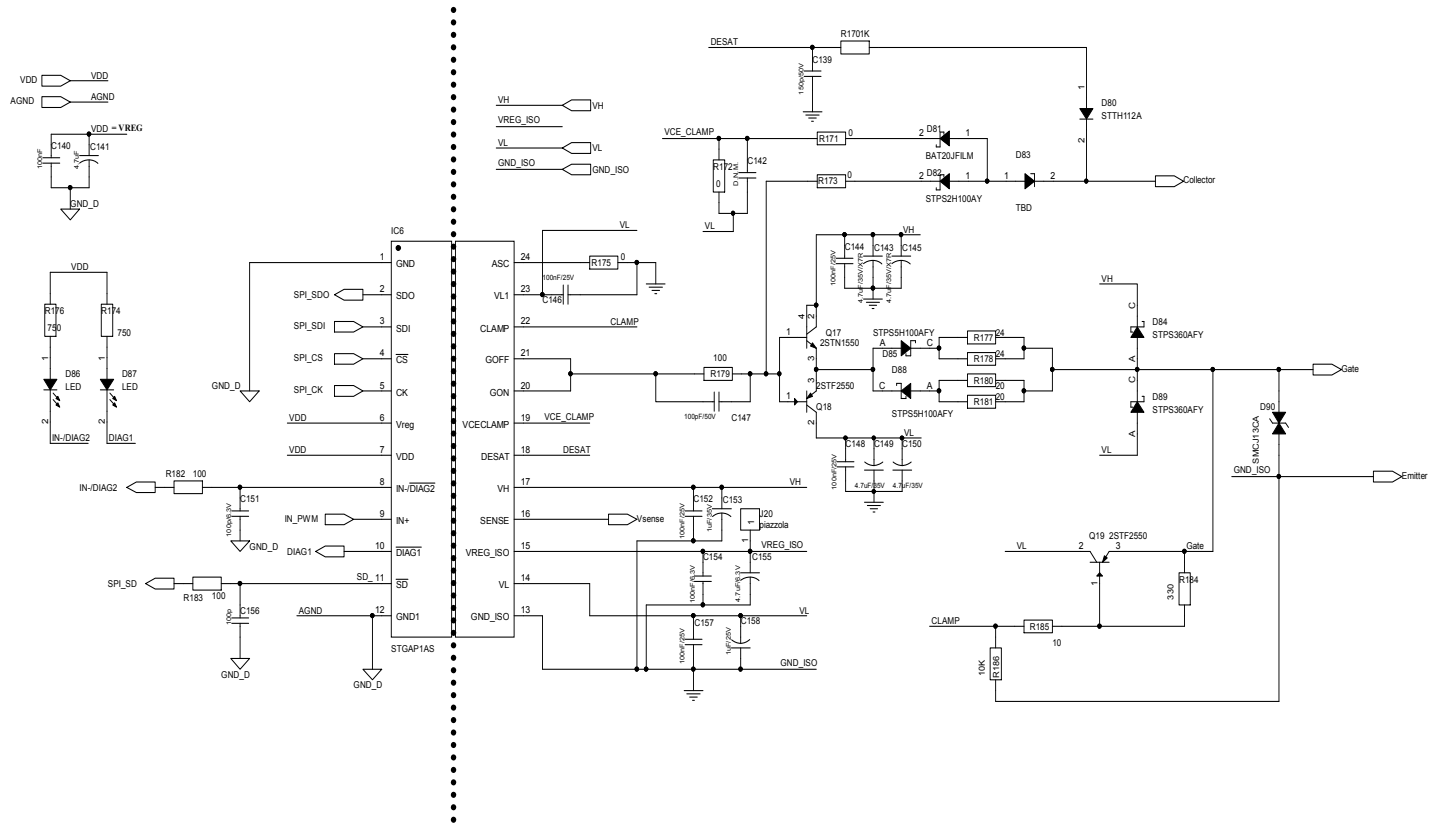

Figure 13. STEVAL-CTM001V2D circuit schematic (13 of 13)

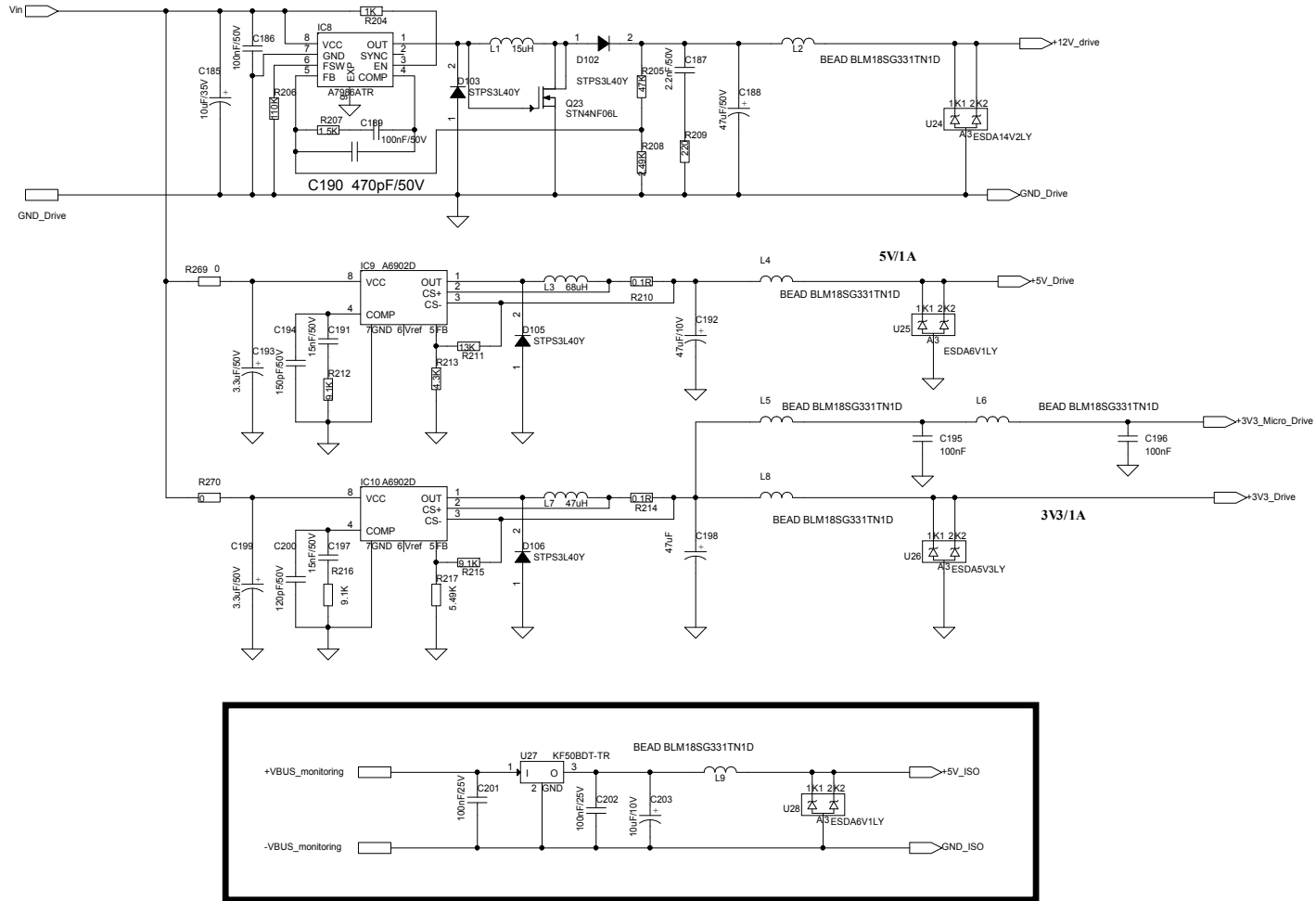

Figure 14. STEVAL-CTM001V1C schematic circuit (1 of 5)

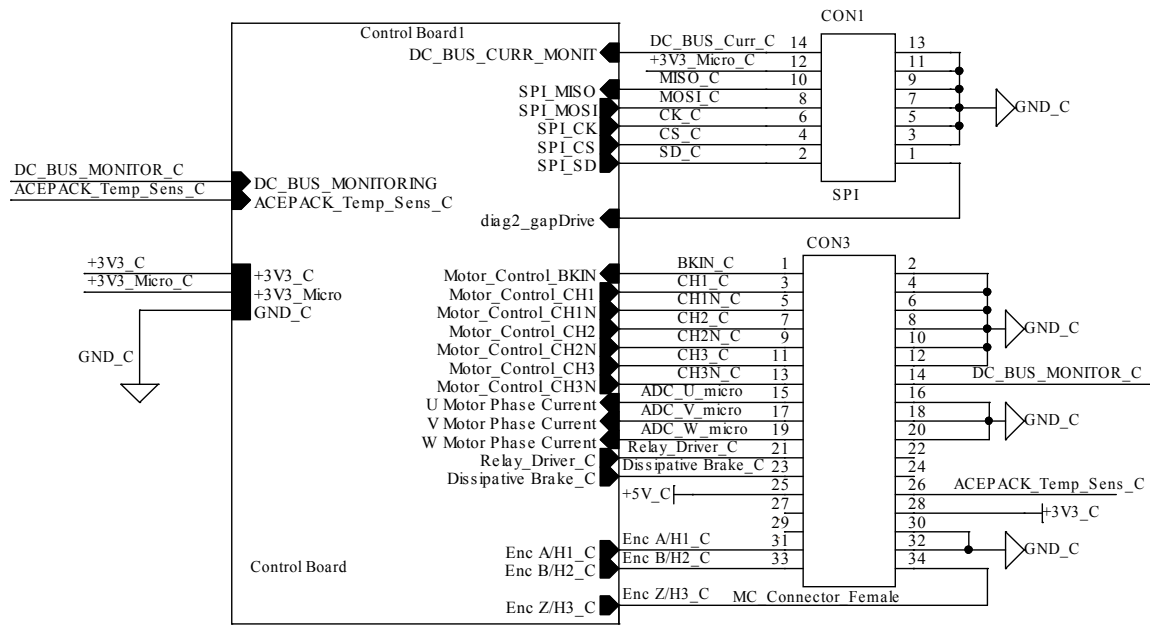

Figure 15. STEVAL-CTM001V1C schematic circuit (2 of 5)

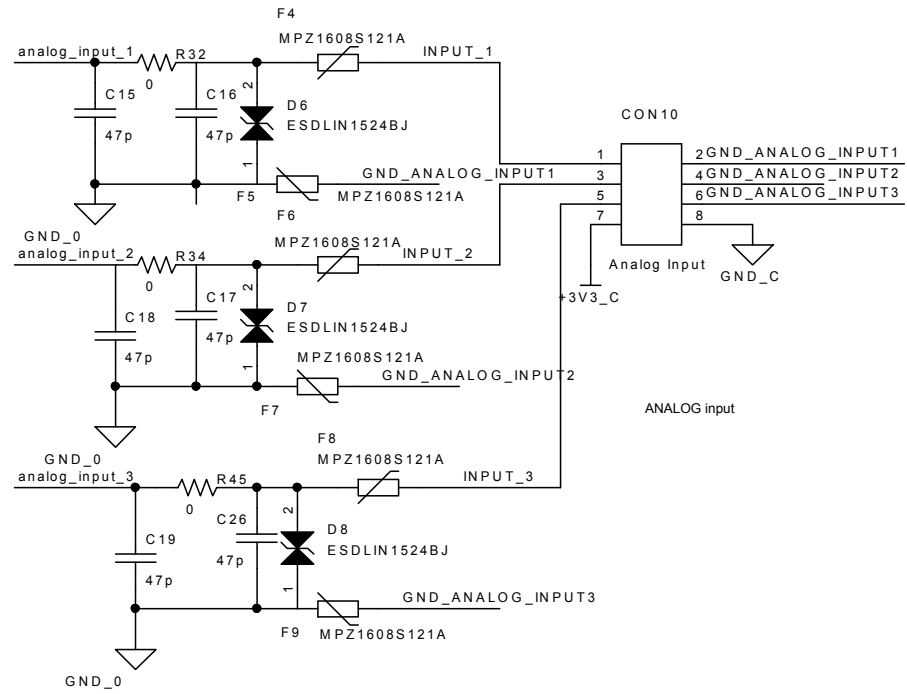

Figure 16. STEVAL-CTM001V1C schematic circuit (3 of 5)

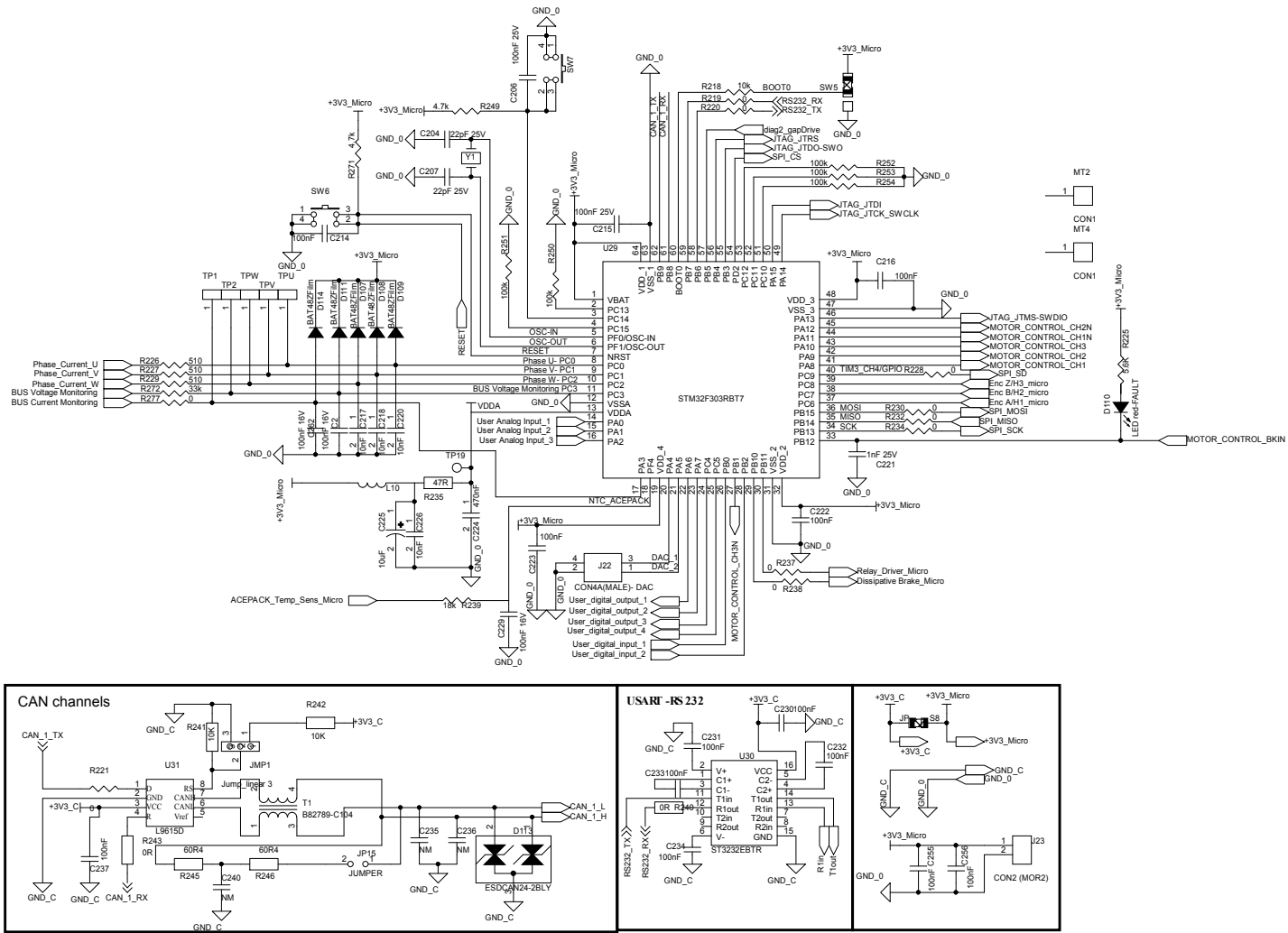

Figure 17. STEVAL-CTM001V1C schematic circuit (4 of 5)

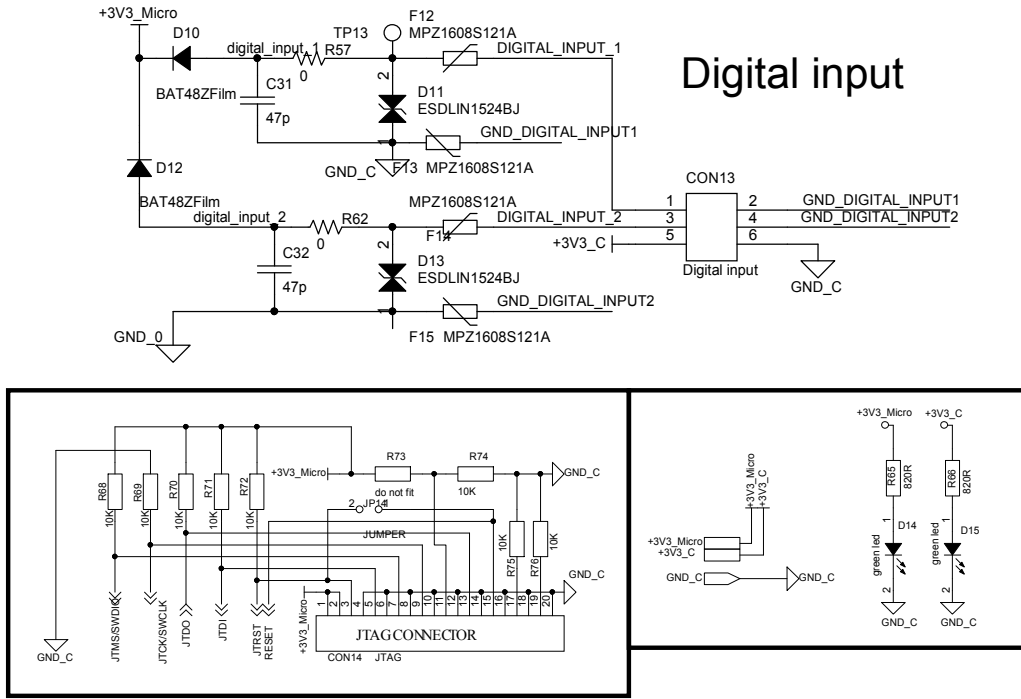

Figure 18. STEVAL-CTM001V1C schematic circuit (5 of 5)

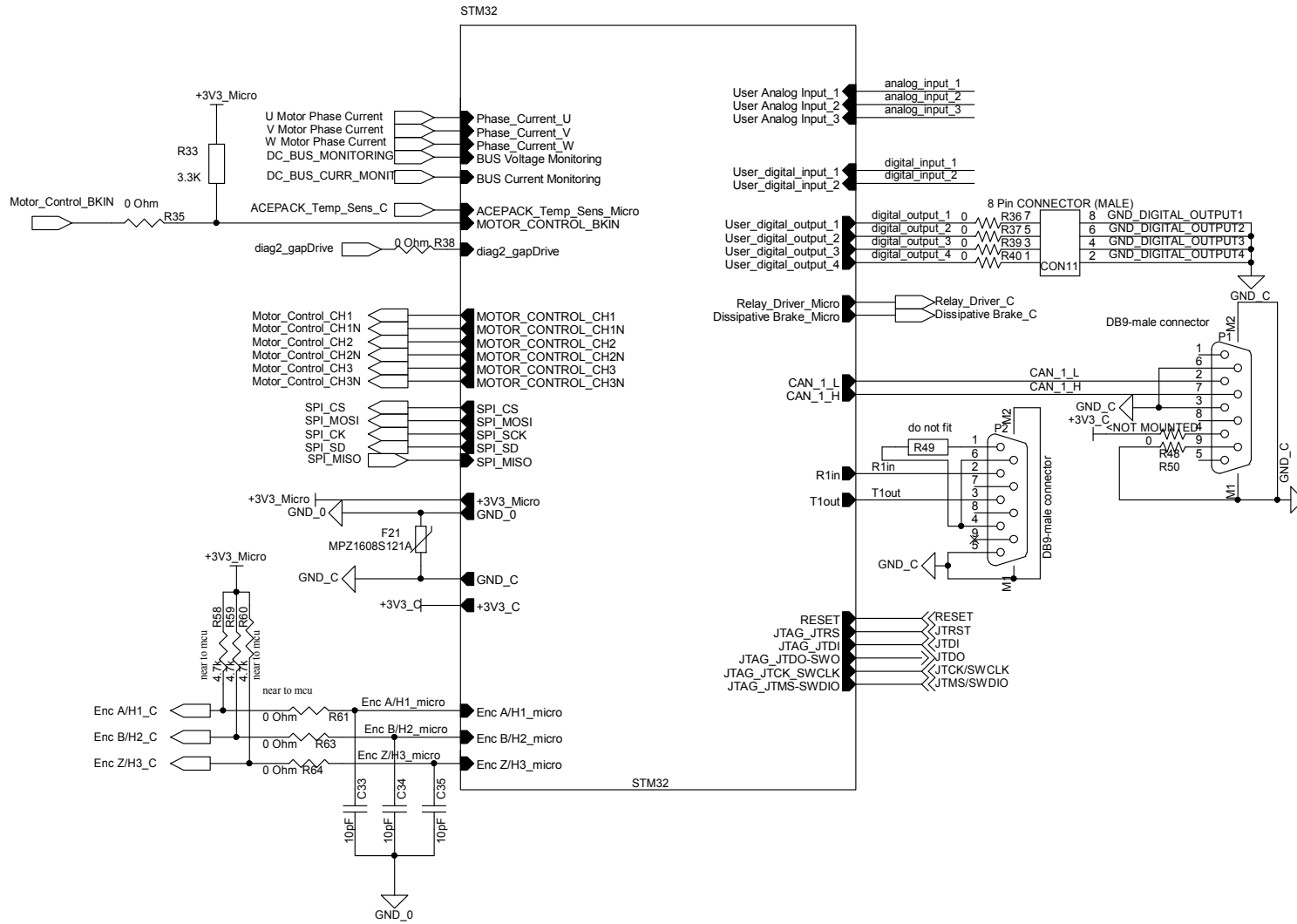

Figure 19. STEVAL-CTM002V2 schematic circuit (1 of 3)

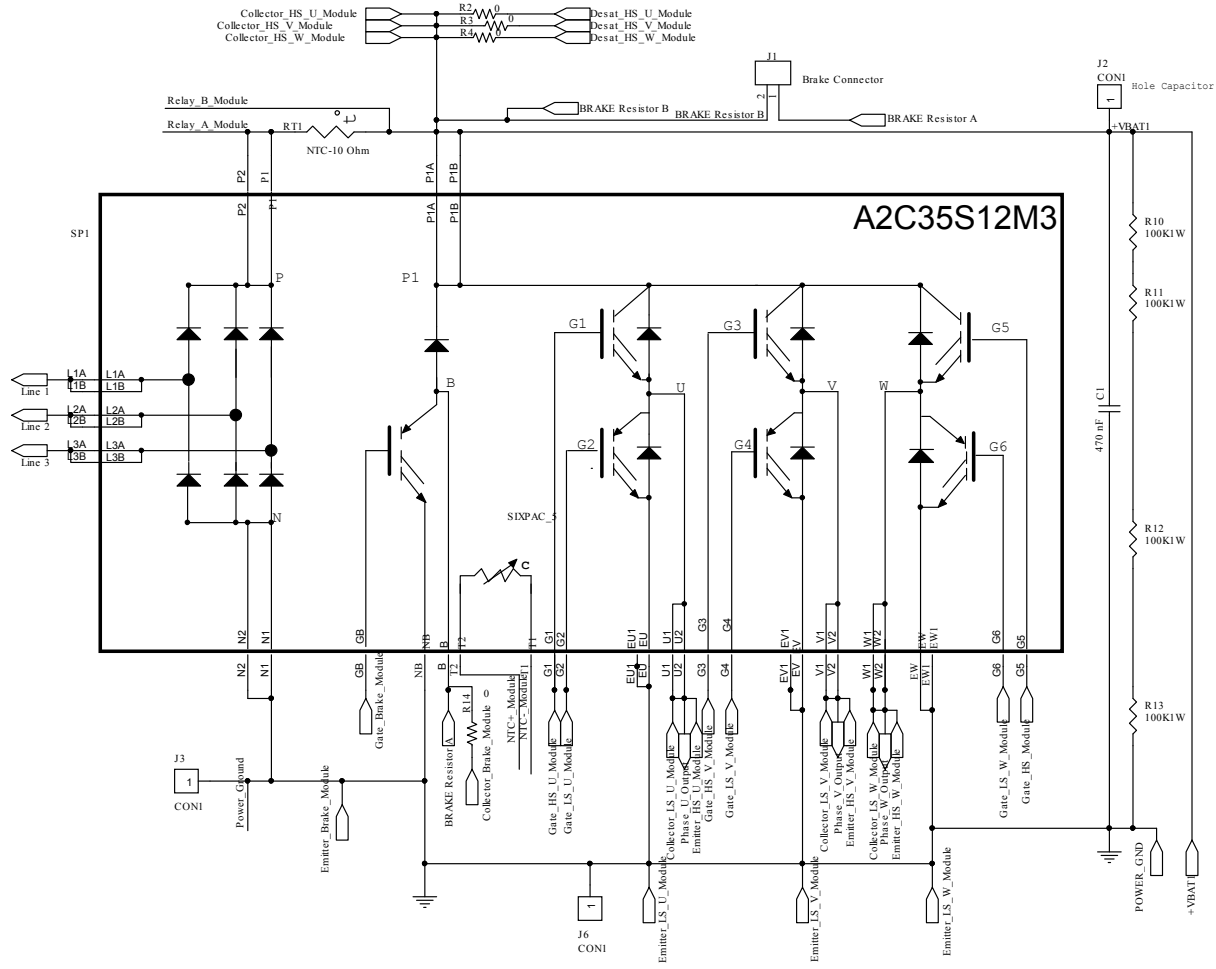

Figure 20. STEVAL-CTM002V2 schematic circuit (2 of 3)

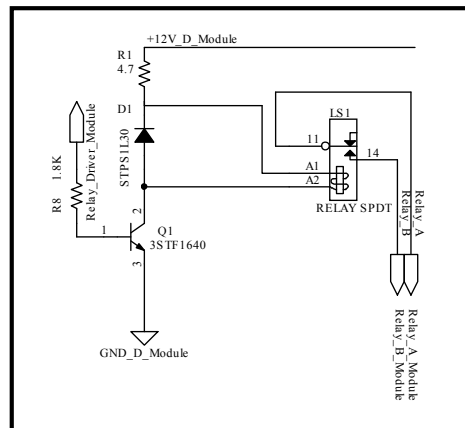
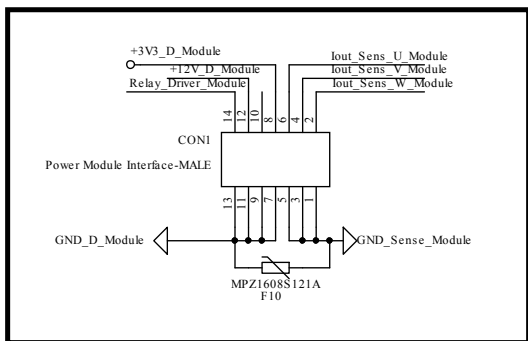
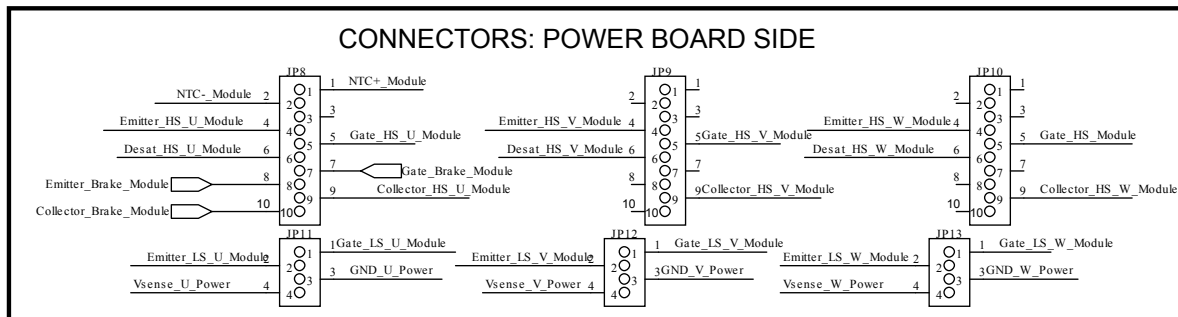
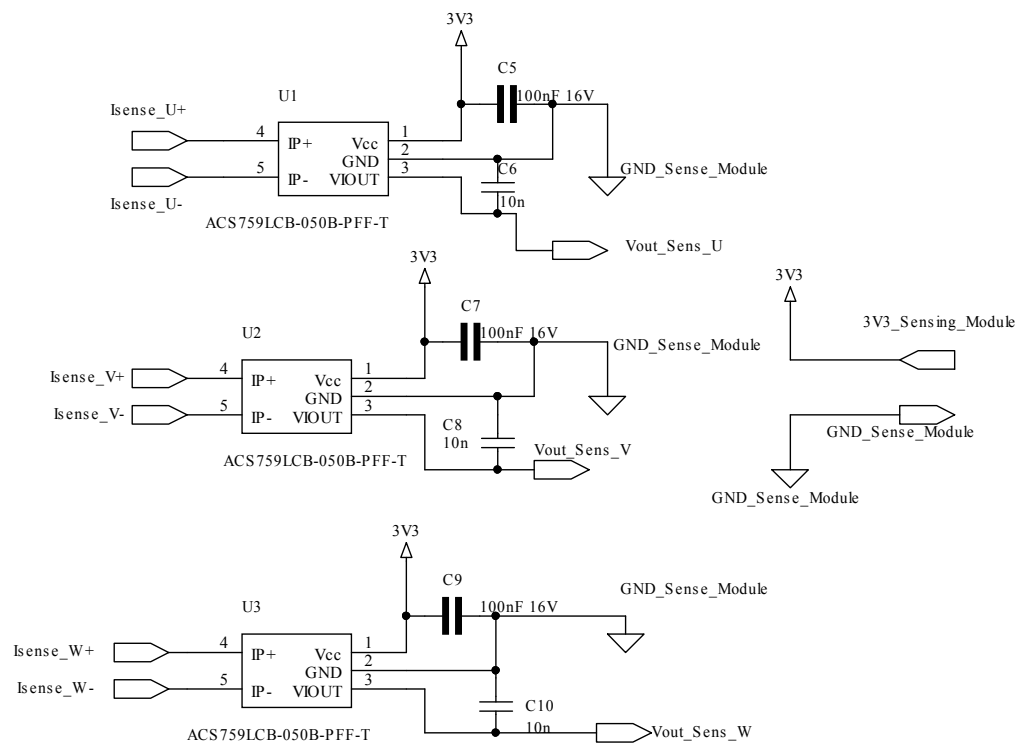
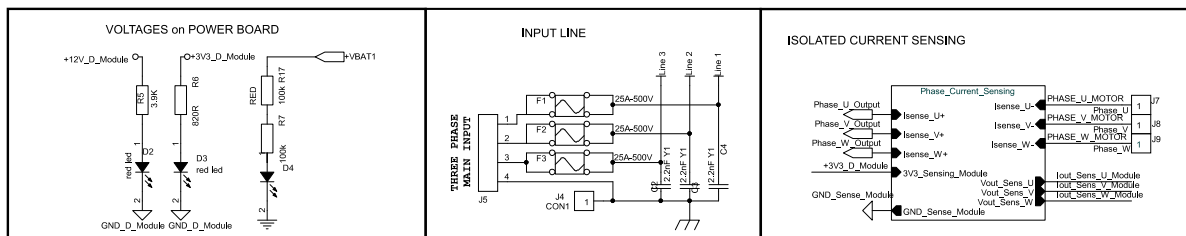

Figure 21. STEVAL-CTM002V2 schematic circuit (3 of 3)



Revision history

Table 1. Document revision history

Date	Version	Changes
08-Nov-2019	1	Initial release.
18-Nov-2019	2	Updated Cover image and Section 1 Schematic diagrams

IMPORTANT NOTICE – PLEASE READ CAREFULLY

STMicroelectronics NV and its subsidiaries (“ST”) reserve the right to make changes, corrections, enhancements, modifications, and improvements to ST products and/or to this document at any time without notice. Purchasers should obtain the latest relevant information on ST products before placing orders. ST products are sold pursuant to ST’s terms and conditions of sale in place at the time of order acknowledgement.

Purchasers are solely responsible for the choice, selection, and use of ST products and ST assumes no liability for application assistance or the design of Purchasers’ products.

No license, express or implied, to any intellectual property right is granted by ST herein.

Resale of ST products with provisions different from the information set forth herein shall void any warranty granted by ST for such product.

ST and the ST logo are trademarks of ST. For additional information about ST trademarks, please refer to www.st.com/trademarks. All other product or service names are the property of their respective owners.

Information in this document supersedes and replaces information previously supplied in any prior versions of this document.

© 2019 STMicroelectronics – All rights reserved