

THIS DRAWING AND THE SUBJECT MATTER SHOWN THEREON ARE CONFIDENTIAL AND THE PROPERTY OF BEL/STEWART/TRP CONNECTOR AND SHALL NOT BE REPRODUCED, COPIED, OR USED IN ANY MANNER WITHOUT THE WRITTEN CONSENT OF TRP CONNECTOR.

PRODUCT MAY BE PROTECTED BY ONE OR MORE OF THE FOLLOWING US PATENTS:
 5736910 5939955 6425781 6428361 6554638 6840817 7123117
 7429195 7717749 7808751 6217391 6149050 7924130

REVISIONS				
#	LT#	DESCRIPTION	DATE	OWN APVD
E	EC-1805035		25MAY2018	JY TY
F	EC-1807016		11JUL2018	TRY TY
G	EC-1810004		08OCT2018	JY TY

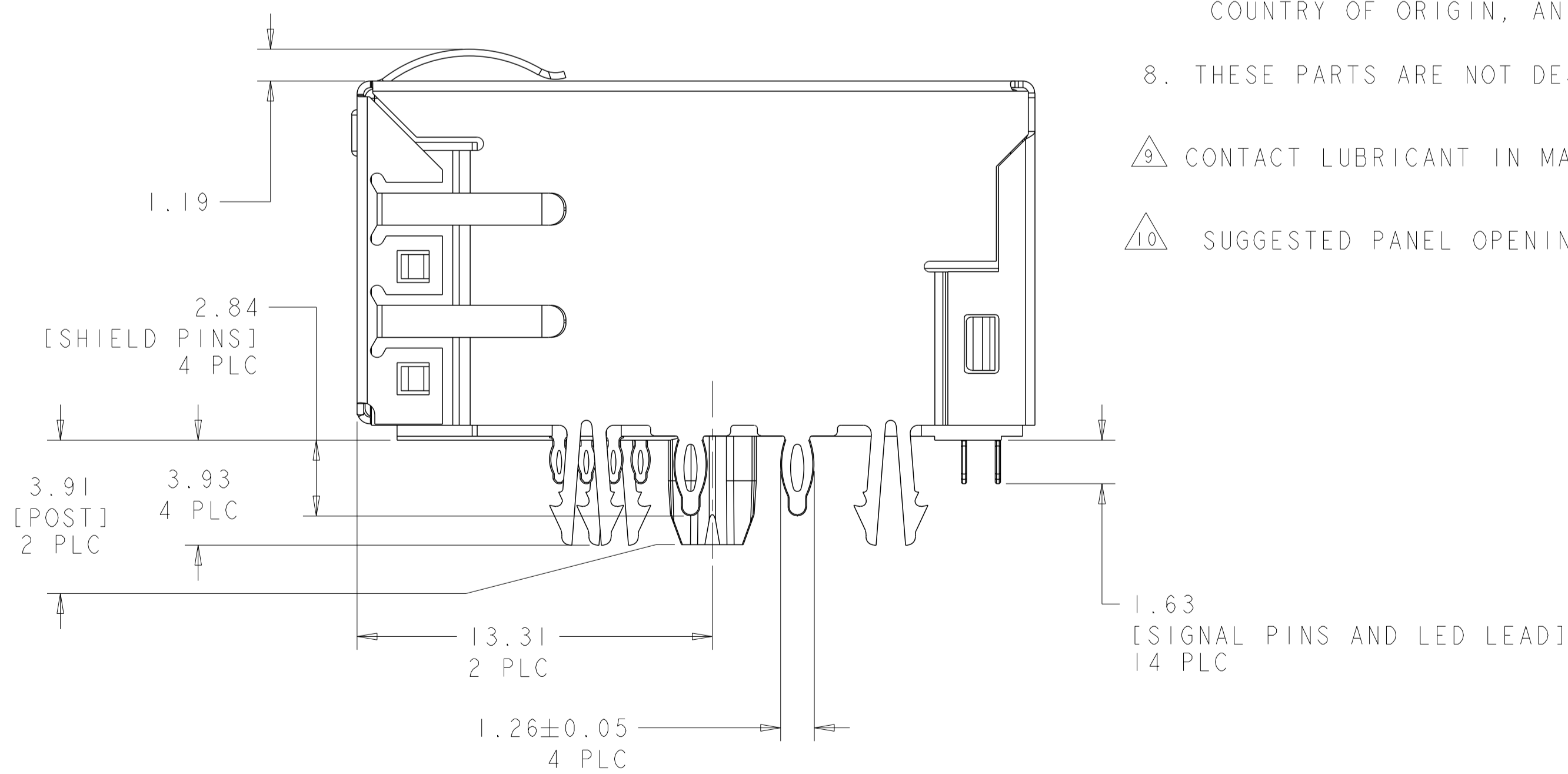
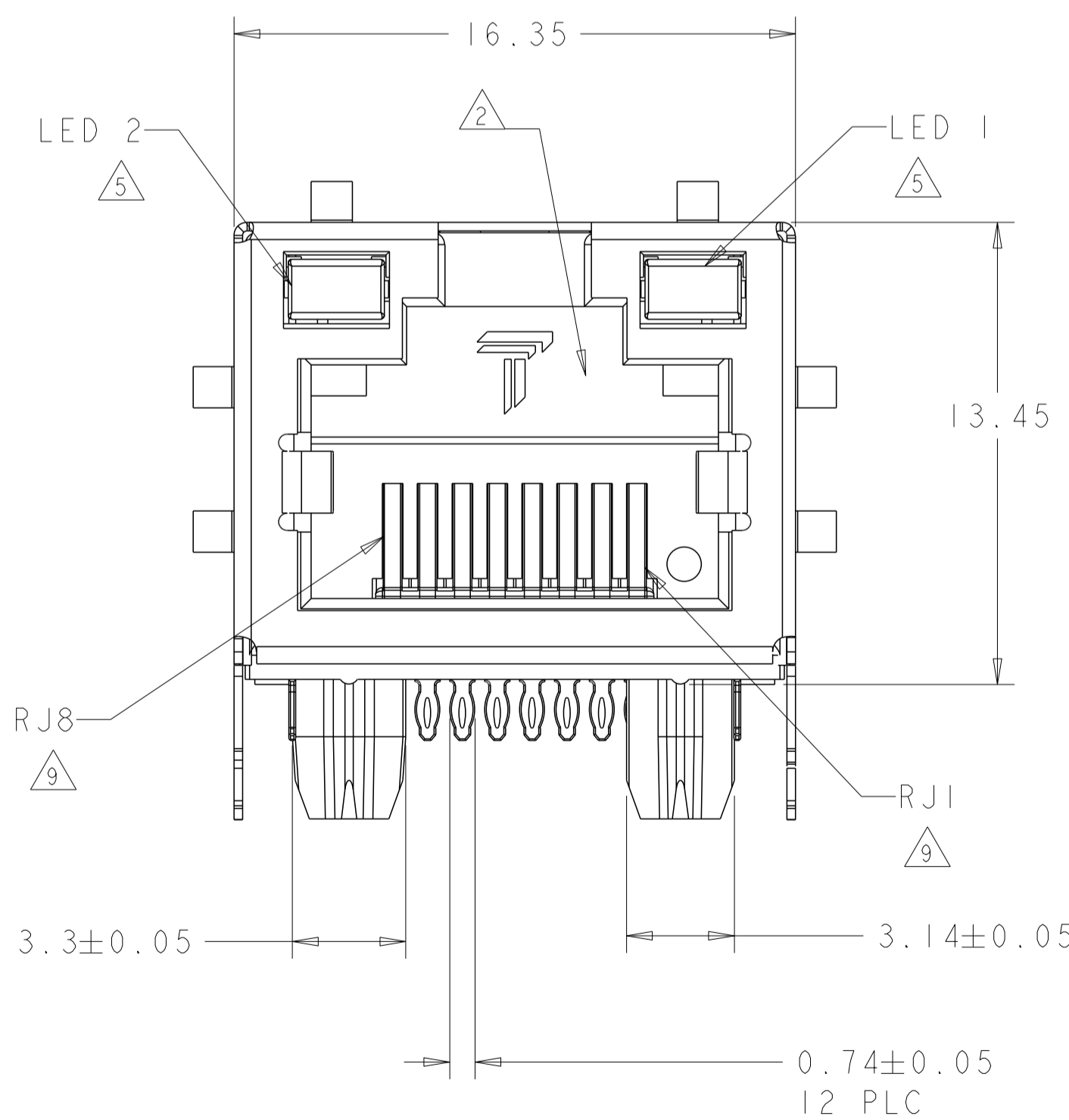
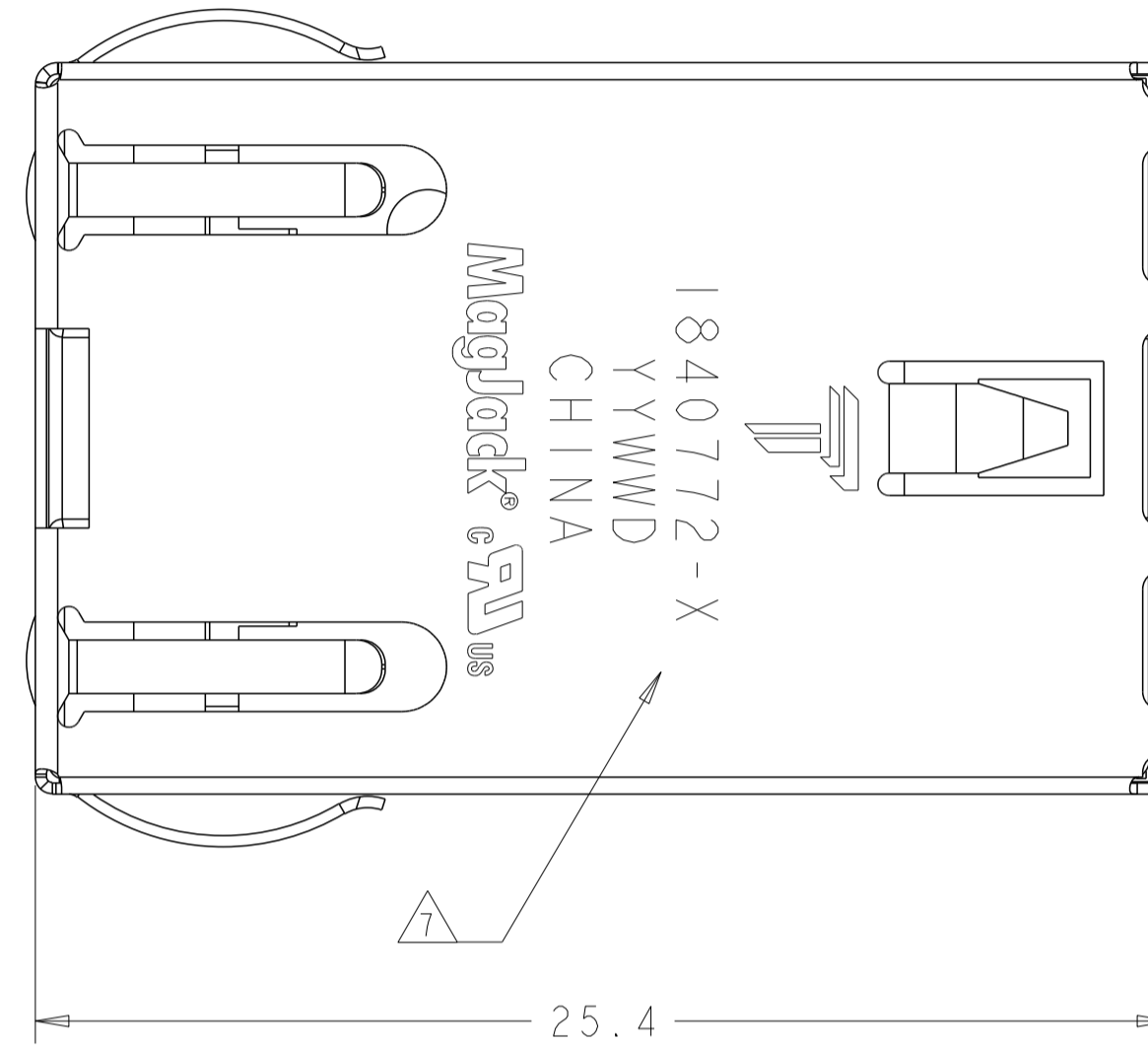
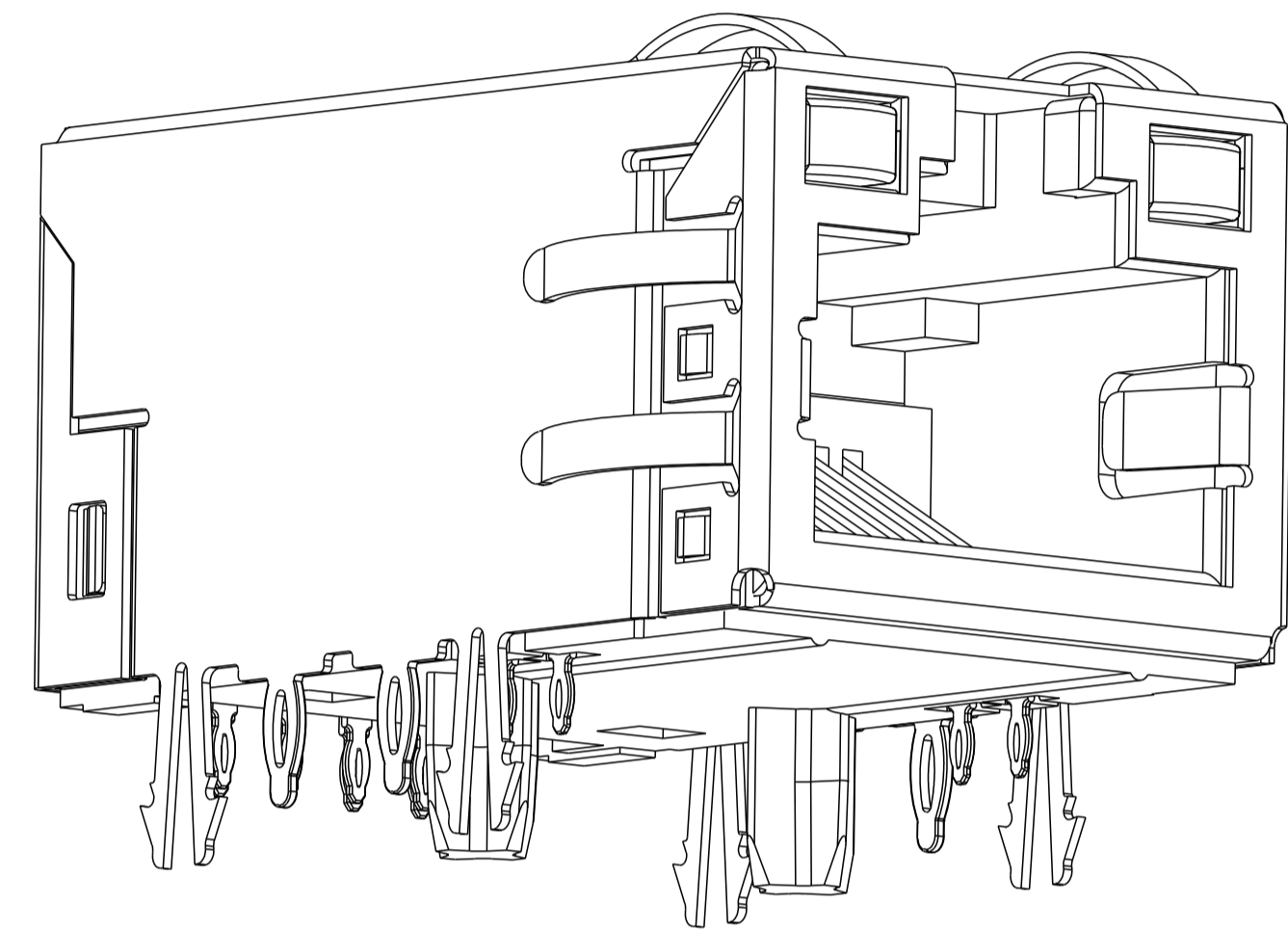

1. MATERIALS:
 -HOUSING: HIGH TEMPERATURE NYLON, BLACK, UL 94V-0
 -SHIELD: 0.25mm THICK, BRASS PREPLATED WITH 0.76 um MIN SEMI-BRIGHT NICKEL;
 -CONTACT TAILS: 0.20mm THICK, PHOSPHOR BRONZE, 1.27 um MIN OVERALL NICKEL UNDERPLATE, 3 um MIN TIN PLATE
 -MOD JACK CONTACTS: 0.25mm THICK, PHOSPHOR BRONZE, 1.27 um MIN OVERALL NICKEL UNDERPLATE, WITH 1.27 um MIN LOCALIZED GOLD PLATE AT PLUG INTERFACE
 -LIGHT EMITTING DIODE (LED): DIFFUSED EPOXY LENS, CARBON STEEL WIREFRAME PREPLATED WITH 2.03 um SILVER PLATE OVER 1.02 um NICKEL OVER 1.02 um COPPER UNDERPLATES; LEADS POST-PLATED WITH 3.05 um TIN.

2. RJ45 JACK CAVITY CONFORMS TO FCC RULES AND REGULATIONS PART 68, SUB-PART F.

3. MAGNETICS
 -APPLICATION: 10/100/1000 BASE-T
 -IMPEDANCE: 100 Ω
 -TURNS RATIO (CHIP:CABLE): 1:1 ALL FOUR PAIRS
 -OPEN CIRCUIT INDUCTANCE (OCL): 350 uH MIN @100kHz, 0.1VRMS, 8mADC BIAS FROM 0 °C TO 70 °C, ALL FOUR PAIRS
 -ALL FOUR PAIRS BI-DIRECTIONAL
 -PERFORMANCE @ 25 °C:
 INSERTION LOSS (IL): 1.1dB MAX FROM 0.5MHz TO 100MHz
 RETURN LOSS (RL): 18dB MIN FROM 0.5MHz TO 40MHz
 12-20LOG(f/80)dB MIN FROM 40.1MHz TO 100MHz
 CROSSTALK ATTENUATION: 35dB MIN FROM 0.5MHz TO 40MHz
 33-20LOG(f/50)dB MIN FROM 40.1MHz TO 100MHz
 COMMON MODE REJECTION RATIO (CMRR): 30dB MIN FROM 0.5MHz TO 100MHz
 -ISOLATION VOLTAGE: 2250VDC (MAX) FOR 60 SECONDS WITH A RISE TIME OF 500V/SEC

4. OPERATING TEMPERATURE: FROM 0°C TO +70°C.

5. LEDs ARE DRIVEN WITH CONSTANT CURRENT AT APPROX 20 mA
 LED COLOR: DOMINANT WAVELENGTH (λD): GREEN 568 nm TYP @ IF=20 mA
 FORWARD VOLTAGE (VF): GREEN 2.2V TYP @ IF=20 mA
 LED COLOR: DOMINANT WAVELENGTH (λD): YELLOW 588 nm TYP @ IF=20 mA
 FORWARD VOLTAGE (VF): YELLOW 2.1V TYP @ IF=20 mA
 LED COLOR: DOMINANT WAVELENGTH (λD): ORANGE 605 nm TYP @ IF=20 mA
 FORWARD VOLTAGE (VF): ORANGE 2.1V TYP @ IF=20 mA

6. ALL DIMENSIONS ARE NOMINAL UNLESS OTHERWISE NOTED.

7. TRADEMARK, PART NUMBER (DETAILED PART NUMBER REFER TO PART LIST), DATE CODE, COUNTRY OF ORIGIN, AND AGENCY APPROVAL MARKING IN APPROXIMATE LOCATION SHOWN

8. THESE PARTS ARE NOT DESIGNED FOR WAVE OR REFLOW SOLDERING APPLICATION

9. CONTACT LUBRICANT IN MATING AREA IS OPTIONAL

10. SUGGESTED PANEL OPENING DIMENSIONS ARE OPTIONAL

WITH	ORANGE	GREEN	1-1840772-7
WITHOUT	GREEN	YELLOW	1840772-8
WITHOUT	GREEN	GREEN	1840772-7
LUBE 9	LED 2	LED 1	PART NO.

THIS DRAWING IS A CONTROLLED DOCUMENT AND COMPLIANT TO ASME Y14.5M		OWN: TOWER YU 04SEP2009	DONGGUAN CHINA
DIMENSIONS: mm		CHK: KE LTH ZHU 04SEP2009	
TOLERANCES UNLESS OTHERWISE SPECIFIED: 0 PLC ±0.25 1 PLC ±0.25 2 PLC ±0.25 3 PLC ±0.25 4 PLC ±0.25 ANGLES ±° APPLICATION SPEC ±°		APVD: KE LTH ZHU 04SEP2009	
PRODUCT SPEC: 108-104013		MODEL NAME: MAGJACK SINGLE NON-POE	DESC: IXI 7G74P2 GIGABIT TAB UP PRESSFIT W/ LED
		SIZE: A1	RESTRICTED TO: G
		CUSTOMER DRAWING	SCALE: 6:1 SHEET 1 OF 3 REV: G

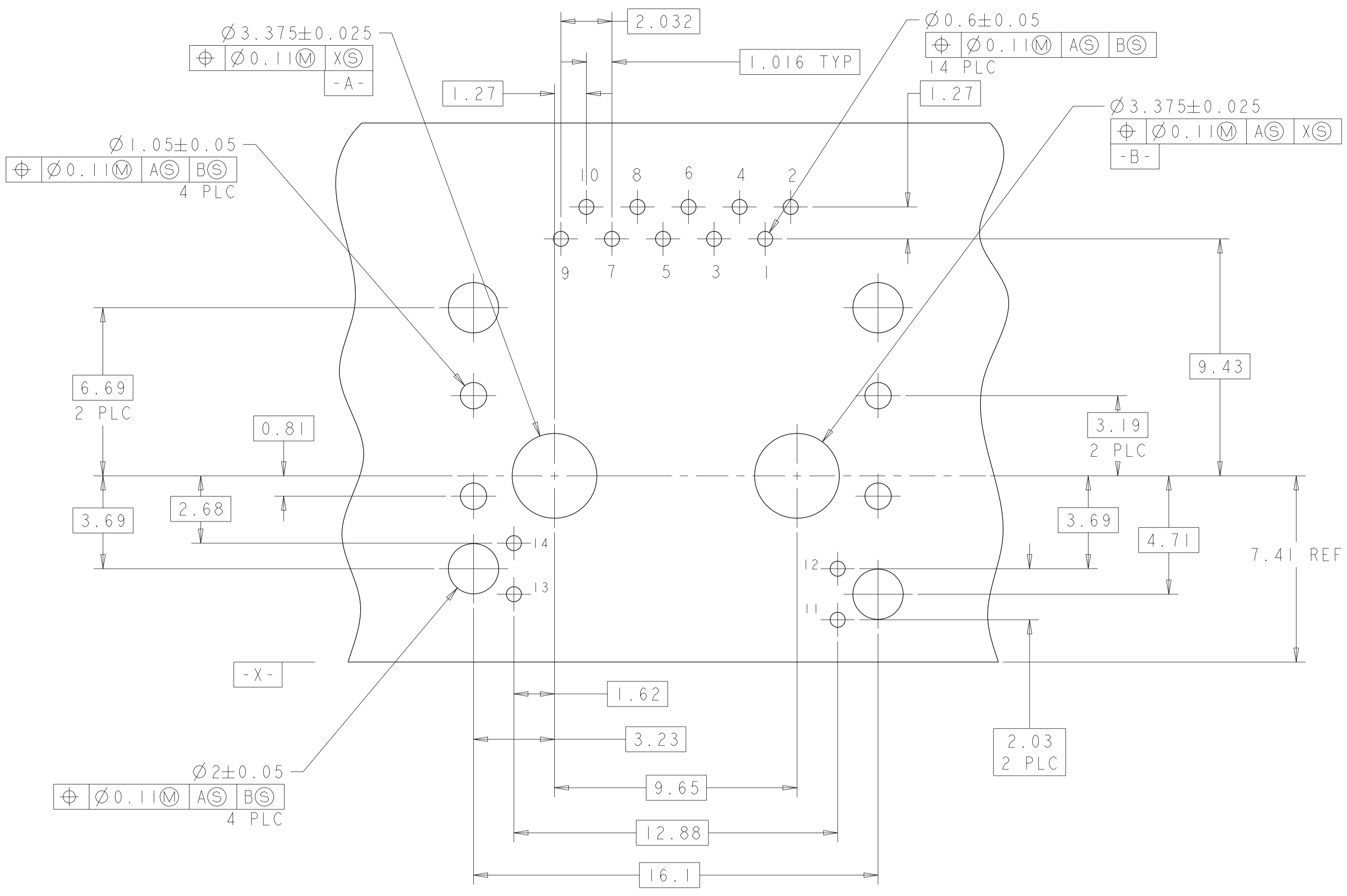

SUGGESTED CUSTOMER BOARD LAYOUT

7G74P2 GIGABIT BASE-T CIRCUIT

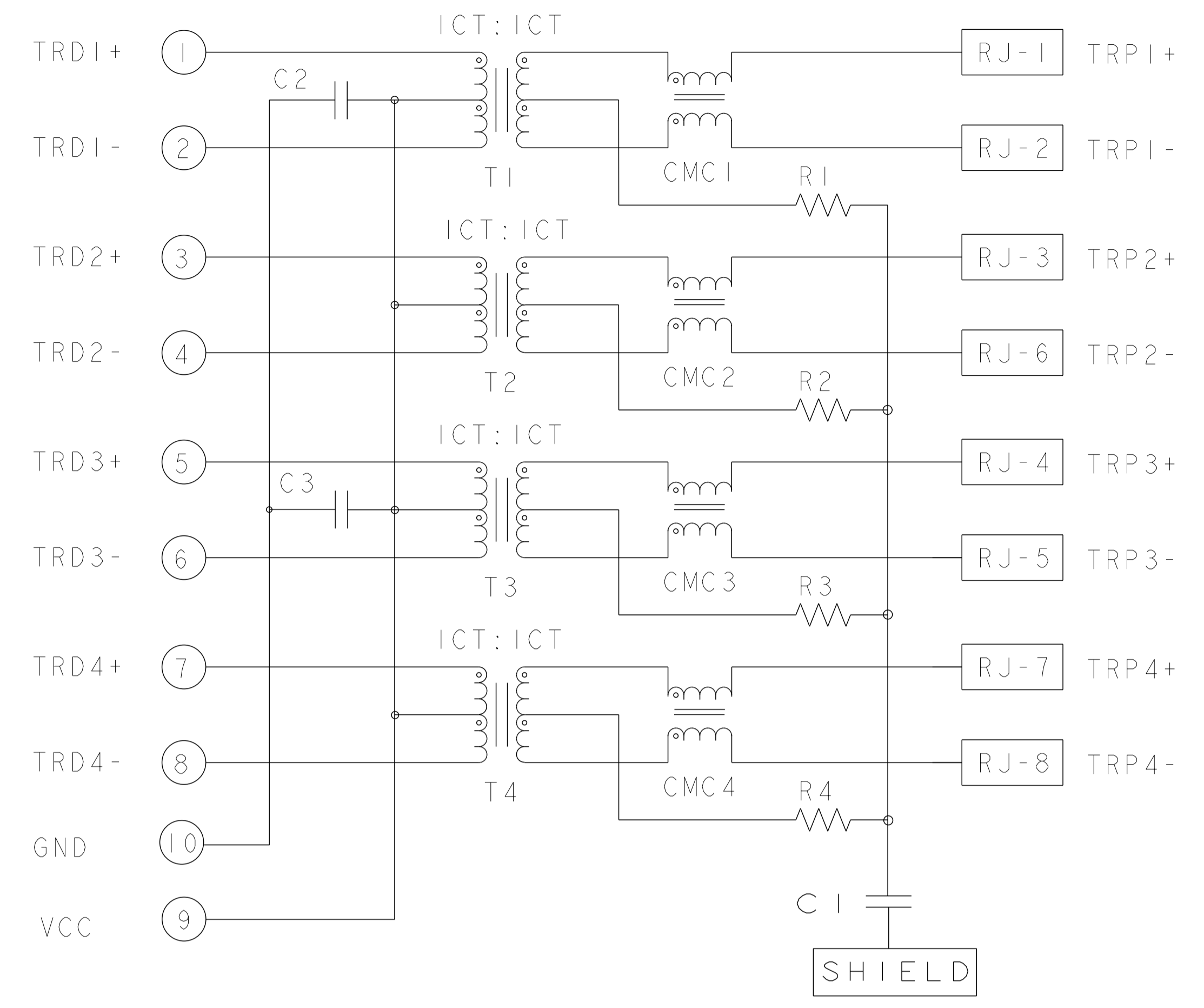

C1=1000PF, 3KV, ±10%, X7R DECOUPLING CAP
 C2 -C3 = 100 nf CAPACITOR
 R1-R4 = 75 OHMS, 1/16W, ±5% RESISTORS

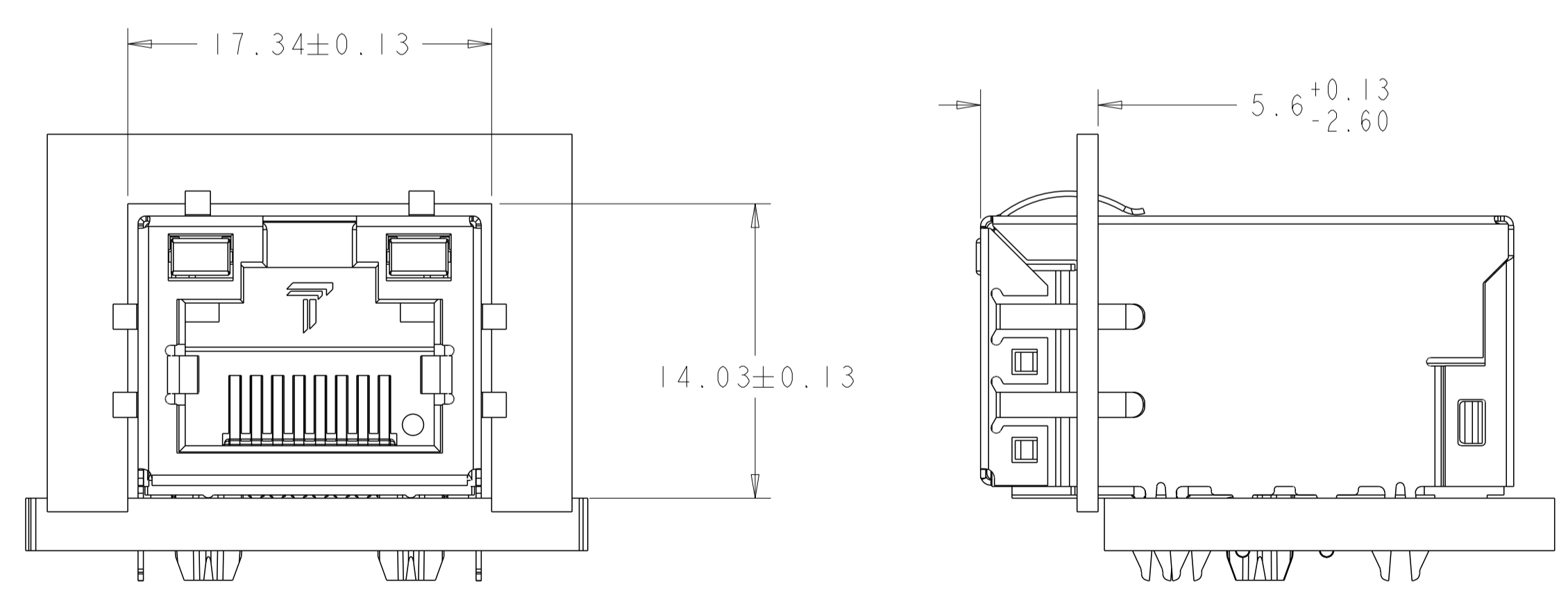

SUGGESTED PANEL OPENING
 OPTION A

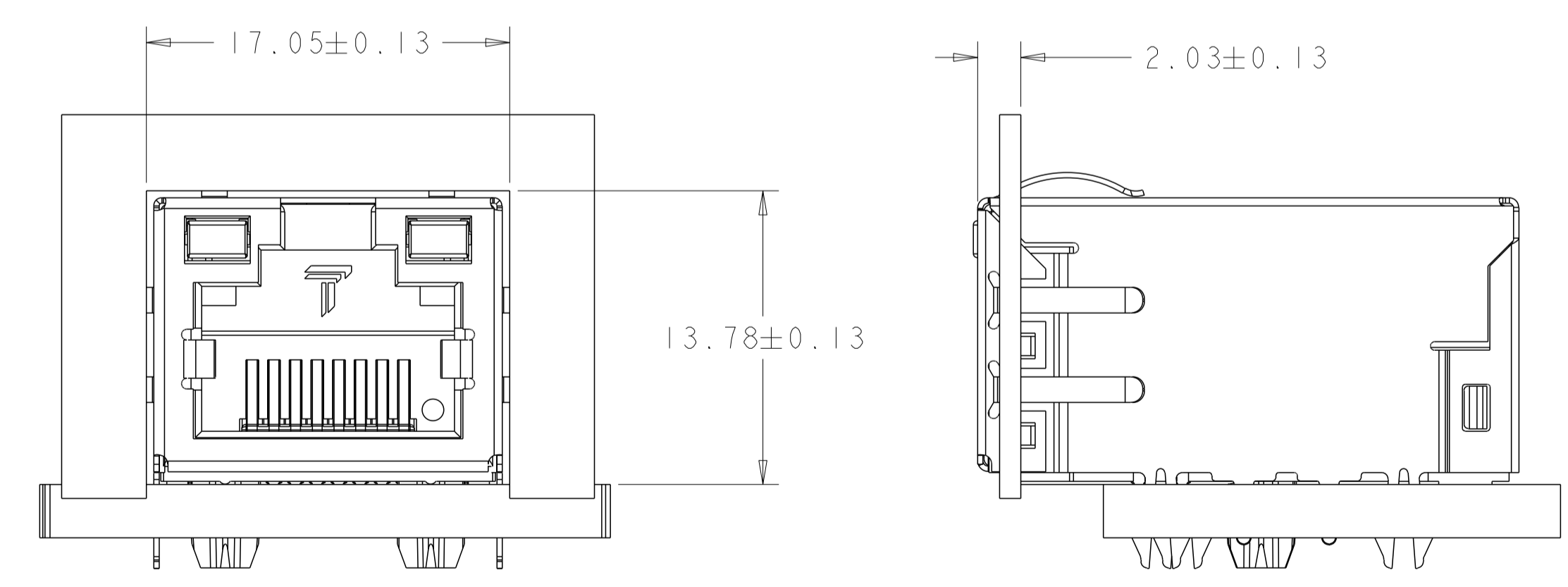

SUGGESTED PANEL OPENING
 OPTION B

THIS DRAWING IS A CONTROLLED DOCUMENT. AND COMPLIANT TO ASME Y14.5M		OWN: TOWER YU 04SEP2009	TRP CONNECTOR a bel group DONGGUAN CHINA
DIMENSIONS: mm		CHK: KE LTH ZHU 04SEP2009	
TOLERANCES UNLESS OTHERWISE SPECIFIED:		APVD: KE LTH ZHU 04SEP2009	DESC: 1X1 7G74P2 GIGABIT TAB UP PRESSFIT W/ LED
0 PLC ±0.25 1 PLC ±0.25 2 PLC ±0.25 3 PLC ± 4 PLC ± ANGLES ± APPLICATION SPEC ±		MODEL NAME: MAGJACK	SIZE: A1
PRODUCT SPEC: 108-104013		CUSTOMER DRAWING	SCALE: 4:1 SHEET 2 OF 3 REV G

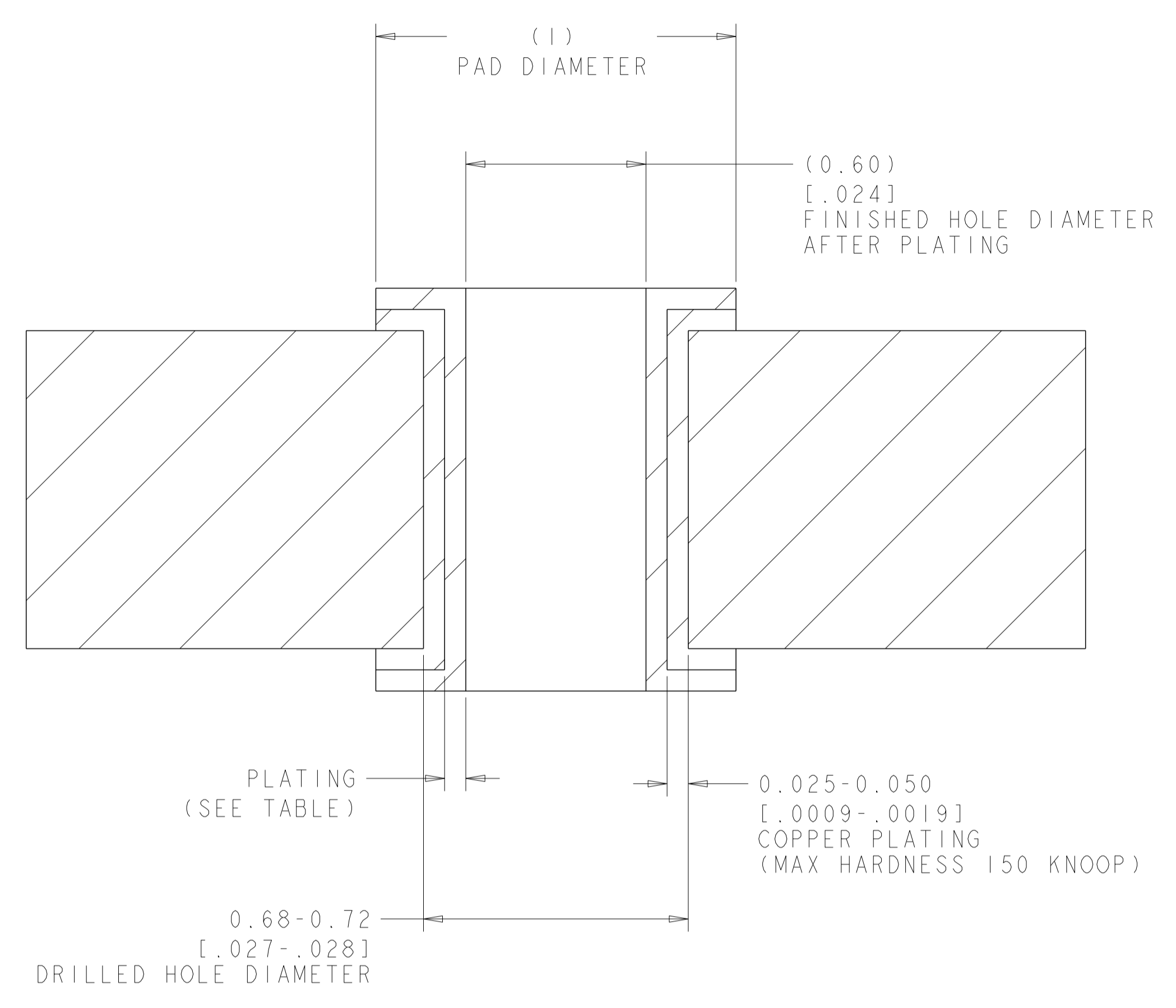

RECOMMENDED HOLE DIMENSIONS
FOR SIGNAL CONTACTS

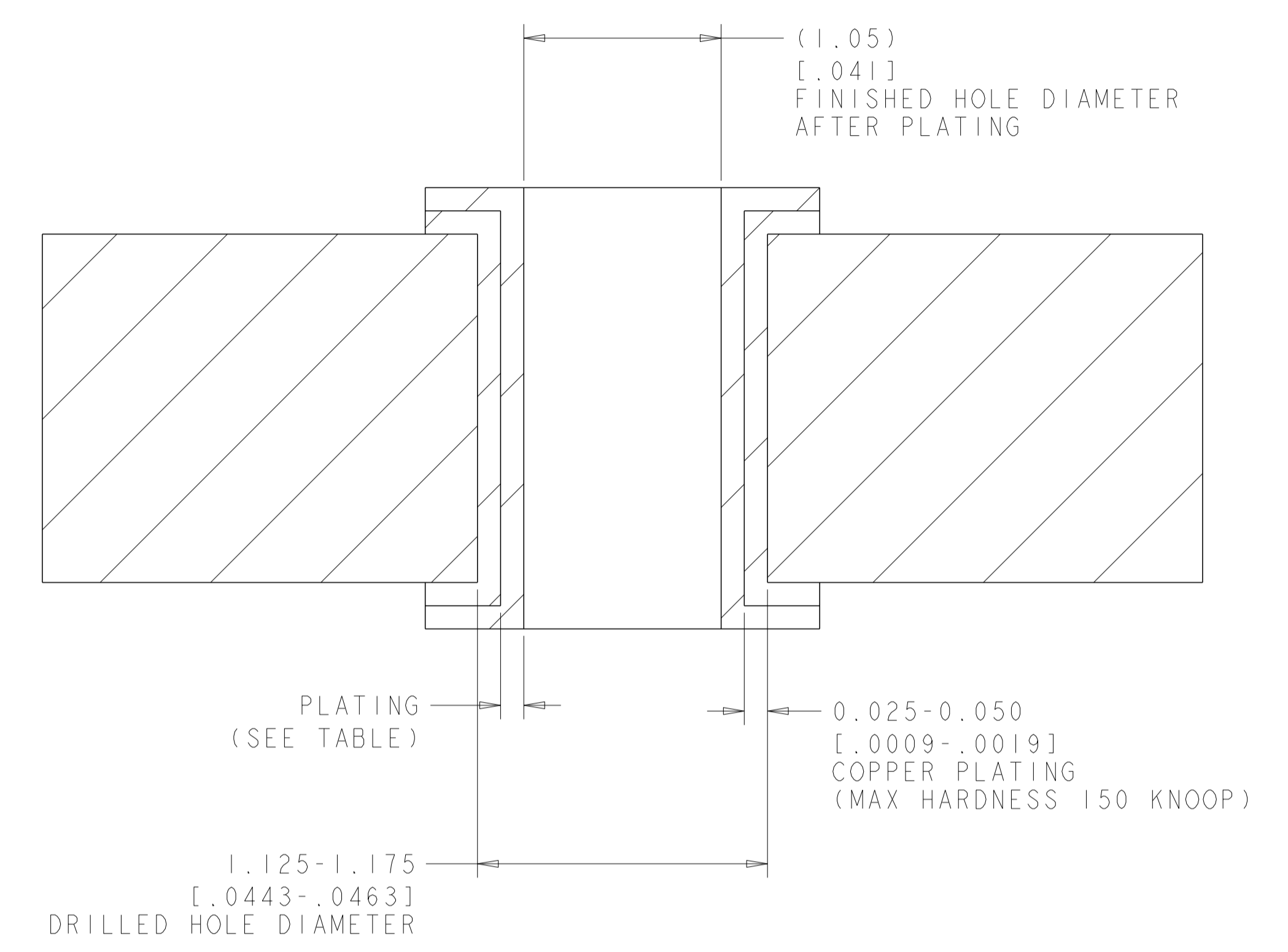

RECOMMENDED HOLE DIMENSIONS
FOR SHIELD CONTACTS

THICKNESS	PLATING
0.004-0.010	HOT AIR SOLDER LEVELING (HASL) TIN-LEAD (Sn Pb)
0.0005-0.001	IMMERSION TIN (Sn)
0.0002-0.0005	ORGANIC SOLDERABILITY PRESERVATIVE (OSP)
0.0001-0.0005 Au, 0.004-0.0076 Ni	IMMERSION GOLD (Au) OVER NICKEL (Ni) (ENIG)
0.010-0.025	TIN LEAD PLATING (Sn Pb)
0.0001-0.00015	IMMERSION SILVER (Ag)

THIS DRAWING IS A CONTROLLED DOCUMENT.
AND COMPLIANT TO ASME Y14.5M

DIMENSIONS:	TOLERANCES UNLESS OTHERWISE SPECIFIED:	OWN: TOWER YU 04SEP2009	<p>trp CONNECTOR DONGGUAN CHINA</p>
mm	0 PLC ±0.25	CHK: KE LTH ZHU 04SEP2009	
	1 PLC ±0.25	APVD: KE LTH ZHU 04SEP2009	
	2 PLC ±0.25		
PRODUCT SPEC	APPLICATION SPEC	MODEL NAME	DESC
108-104013	-	MAGJACK	IXI 7G74P2 GIGABIT TAB UP PRESSFIT W/ LED
		SINGLE NON-POE	SIZE: A1
		CUSTOMER DRAWING	SCALE: 1:1 SHEET 3 OF 3 REV G