

| ITEM | Q'TY | PART NUMBER | PART DESCRIPTION |
|------|------|-------------|---------------------|
| 1 | 1 | C-175 | T-1¼ (5mm) LED CLIP |
| 2 | 1 | R-175 | T-1¼ (5mm) LED RING |

| REV. | DESCRIPTION | DATE | APPROVED |
|------|--------------------------------|----------|----------|
| C | Engineering Update w/o Changes | 02/26/04 | M. C. |
| D | Remove Material Code | 05/28/16 | J. C. |
| | | | |
| | | | |

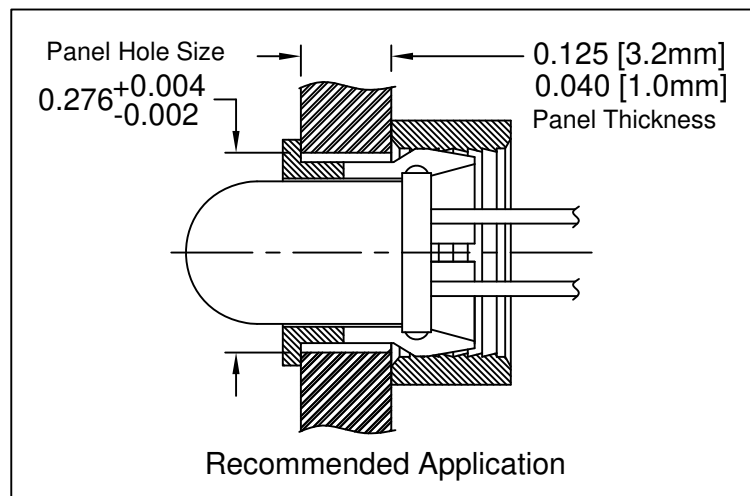
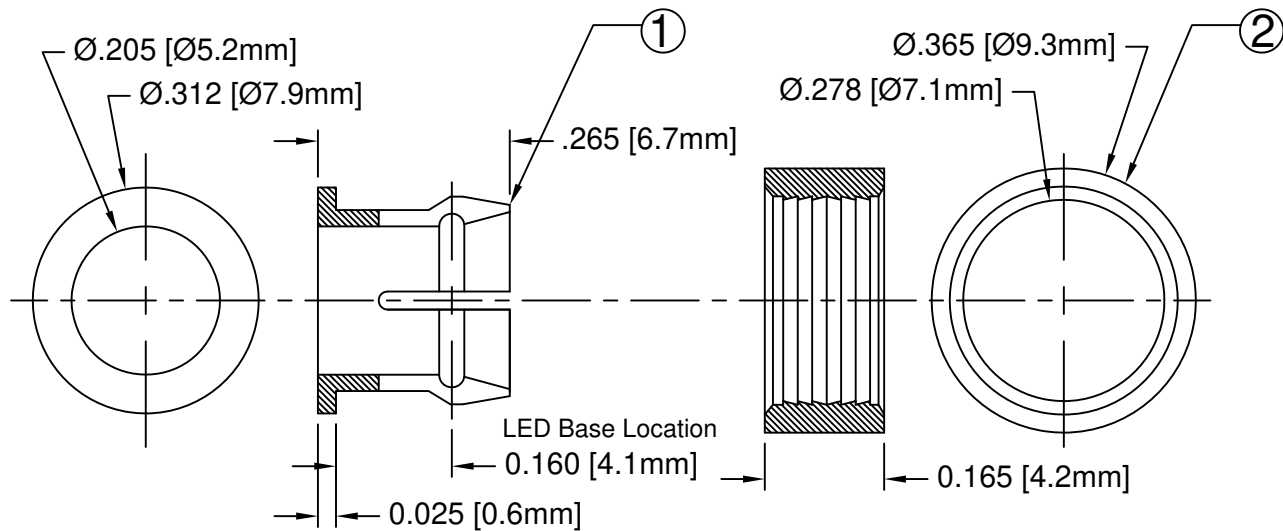

2. MATERIAL: NYLON 6/6, 94V-0, BLACK.

1. GENERAL SPECIFICATIONS: BIVAR MOLDED COMPONENT SPECIFICATION BV00-E101.

| STANDARD TOLERANCE (UNLESS OTHERWISE SPECIFIED) | | BIVAR® | |
|--|--------------------------|---|-----------------------|
| DECIMALS | ANGULAR | 4 THOMAS, IRVINE, CA. 92618 | |
| .X ± .1 | X° ± 1° | TEL: (949) 951-8808 FAX: (949) 951-3974 | |
| .XX ± .01 | | TITLE: CLIP & RING SET FOR SMALL FLANGE T-1¼ (5mm) LED | |
| .XXX ± .005 | | PART NO: CR-175 | REVISION: D |
| DESIGNED: S. Irving | DATE: 11/18/98 | CAGE CODE : 32559 | SHEET # 1 OF 1 |
| CHECKED: M. Chen | DATE: 01/09/02 | CAD GENERATED DOCUMENT. DO NOT MEASURE DRAWING. | |