

## ACDBAT320-HF Thru. ACDBAT3100-HF

Forward current: 3.0A

Reverse voltage: 20 to 100V

RoHS Device  
Halogen Free



### Features

- Lead less chip form, no lead damage.
- Low power loss, High efficiency.
- High current capability, low VF
- Plastic package has UL 94V-0.
- Comply with AEC-Q101

### Mechanical Data

- Case: Packed with FRP substrate and epoxy underfilled.
- Terminals: Pure Tin plated (Lead-Free),solderable per MIL-STD-750, method 2026.
- Polarity: Laser cathode band marking.
- Weight: 0.02 grams (approx).

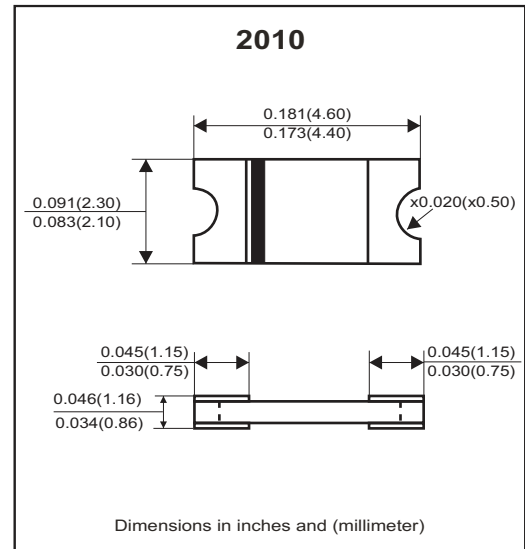

### Circuit Diagram



### Maximum Ratings (At Ta=25°C, unless otherwise noted)

Parameter	Symbol	ACDBAT320-HF	ACDBAT340-HF	ACDBAT360-HF	ACDBAT3100-HF	Unit
Non-repetitive peak reverse voltage	V <sub>RM</sub>	20	40	60	100	V
Average forward current	I <sub>F(AV)</sub>	3				A
Peak forward surge current @8.3ms single half sine-wave	I <sub>FSM</sub>	80				A
Operating junction temperature range	T <sub>J</sub>	-55 to +125		-55 to +150		°C
Storage temperature	T <sub>STG</sub>	-55 ~ +150				°C

### Electrical Characteristics (At Ta=25°C, unless otherwise noted)

Parameter	Conditions	Type	Symbol	Min.	Typ.	Max.	Unit
Forward voltage (Note1)	I <sub>F</sub> =1.0A I <sub>F</sub> =3.0A	ACDBAT320-HF	V <sub>F</sub>	-	0.37	-	V
		ACDBAT340-HF		-	0.46	0.50	
	ACDBAT360-HF	-		0.42	-		
		I <sub>F</sub> =1.0A I <sub>F</sub> =3.0A		-	0.58	0.70	
ACDBAT3100-HF	I <sub>F</sub> =1.0A	-	0.58	-			
	I <sub>F</sub> =3.0A	-	0.75	0.85			
Reverse peak reverse current	V <sub>R</sub> =Max.V <sub>RRM</sub> , Ta=25°C		I <sub>RRM</sub>	-	0.02	0.2	mA
Junction capacitance	V <sub>R</sub> =4V, f=1.0MHz		C <sub>j</sub>	-	120	-	pF
Thermal resistance	Junction to ambient (Note 2)		R <sub>θJA</sub>	-	86	-	°C/W
	Junction to lead (Note 2)		R <sub>θJL</sub>	-	24	-	°C/W

Notes: (1) Pulse test width pw=300usec, 1% duty cycle.

(2) Mounted on P.C. board with 0.2\*0.2"(5.0\*5.0mm) copper pad areas.

Company reserves the right to improve product design , functions and reliability without notice.

REV:B

## RATING AND CHARACTERISTIC CURVES (ACDBAT320-HF Thru. ACDBAT3100-HF)

Fig.1- Typical Forward Current Derating Curve

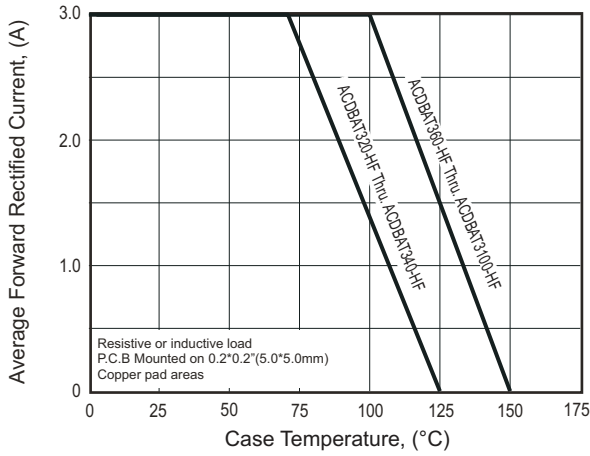

Fig.2- Maximum Non-Repetitive Peak Forward Surge Current

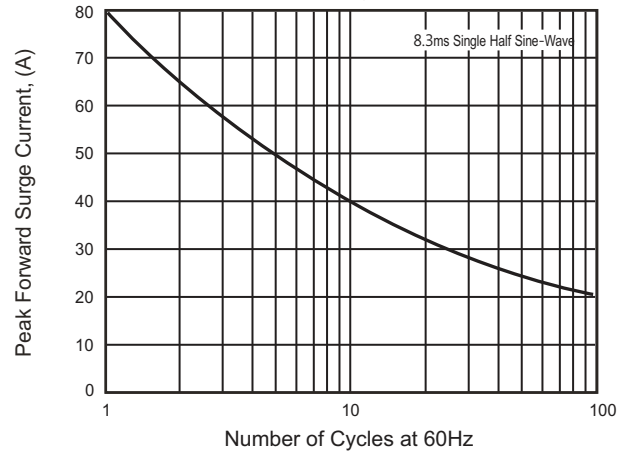

Fig.3- Typical Instantaneous Forward Characteristics

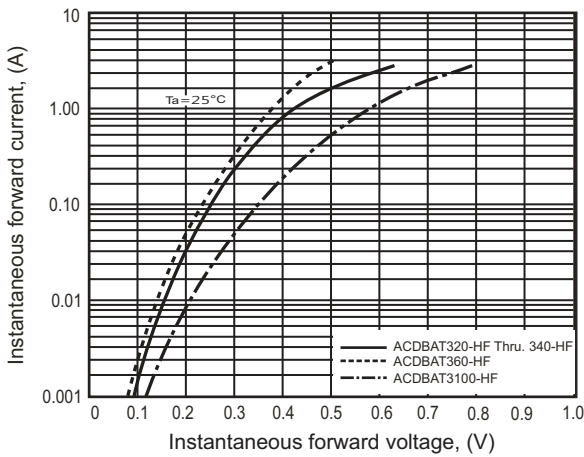

Fig.4- Typical Reverse Characteristics

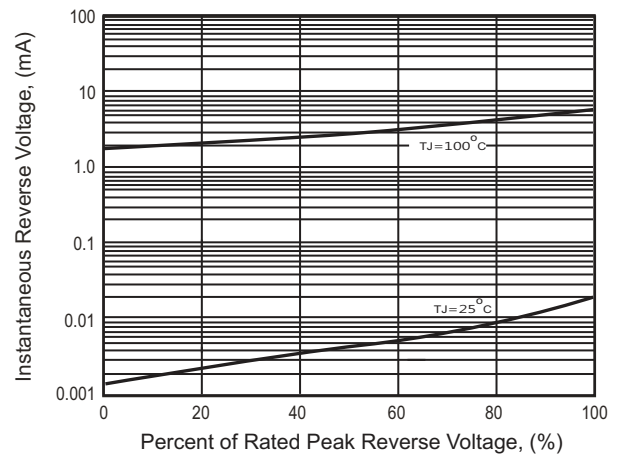
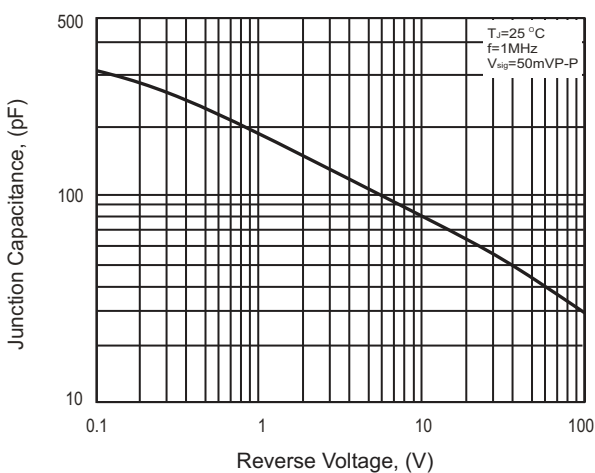
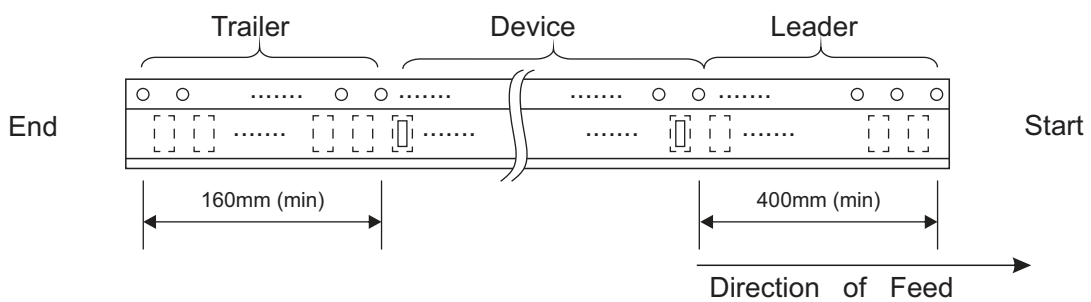
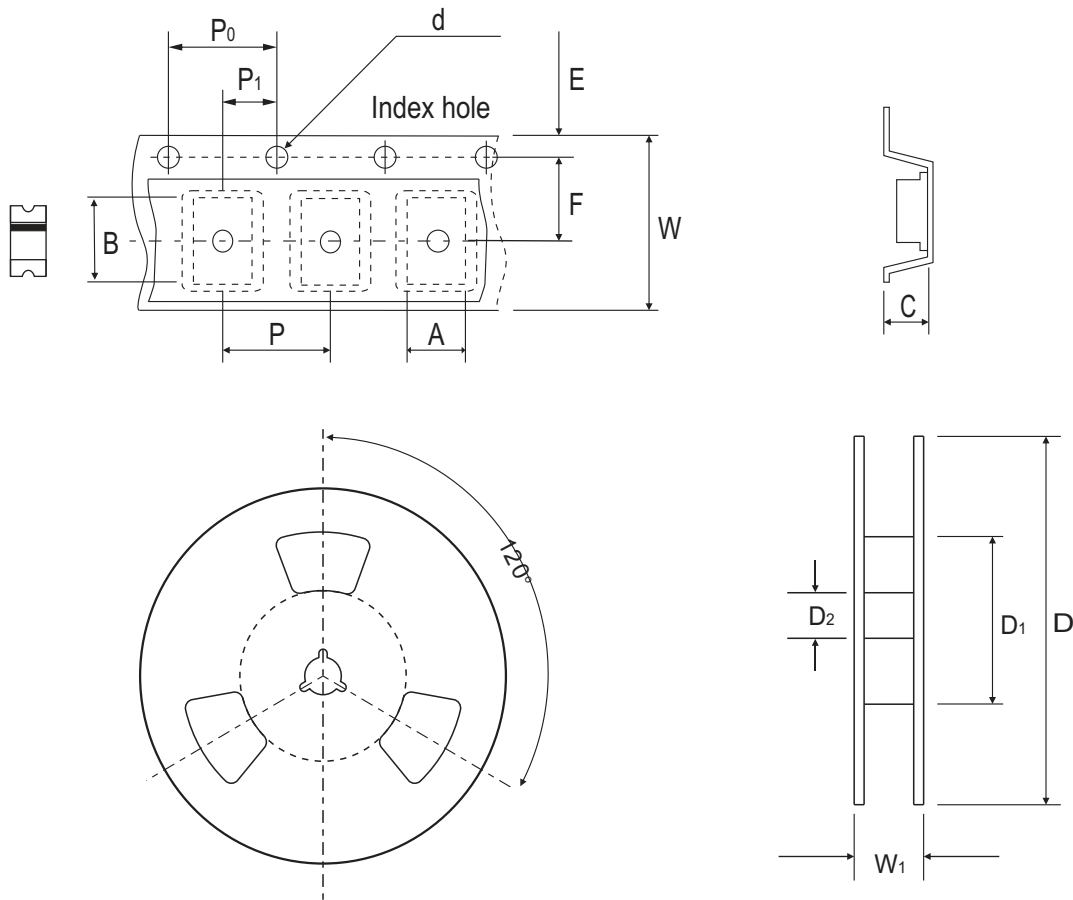

Fig.5- Typical Junction Capacitance



## Reel Taping Specification



2010	SYMBOL	A	B	C	d	D	D <sub>1</sub>	D <sub>2</sub>
	(mm)	4.75 ± 0.10	2.45 ± 0.10	1.30 ± 0.10	1.50 ± 0.10	178.00 ± 2.00	50.00 MIN.	13.00 ± 0.50
	(inch)	0.187 ± 0.004	0.096 ± 0.004	0.051 ± 0.004	0.059 ± 0.004	7.008 ± 0.079	1.969 MIN.	0.512 ± 0.020

2010	SYMBOL	E	F	P	P <sub>0</sub>	P <sub>1</sub>	W	W <sub>1</sub>
	(mm)	1.75 ± 0.10	5.50 ± 0.05	4.00 ± 0.10	4.00 ± 0.10	2.00 ± 0.10	12.00 ± 0.30	18.70 MAX.
	(inch)	0.069 ± 0.004	0.217 ± 0.002	0.157 ± 0.004	0.157 ± 0.004	0.079 ± 0.004	0.472 ± 0.012	0.736 MAX.

## Marking Code

Part Number	Marking Code
ACDBAT320-HF	2
ACDBAT340-HF	4
ACDBAT360-HF	6
ACDBAT3100-HF	10

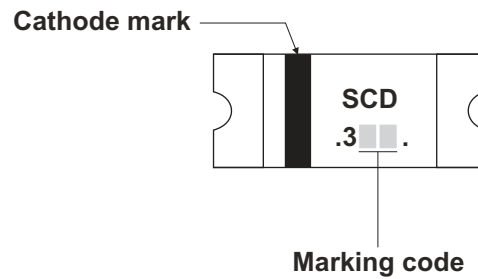

## Suggested PAD Layout

SIZE	2010	
	(mm)	(inch)
A	1.47MIN.	0.058MIN.
B	1.27MIN.	0.050MIN.
C	2.60MAX.	0.102MAX.
D	5.14REF.	0.202 REF.

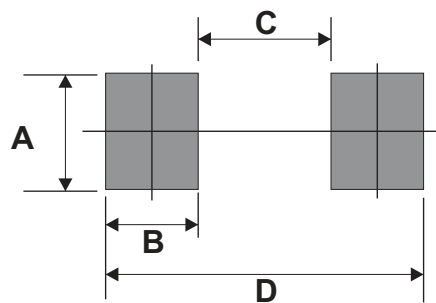

## Standard Packaging

Case Type	REEL PACK	
	REEL ( pcs )	Reel Size (inch)
2010	3,000	7