



ULTRA LOW VOS EPAD® DUAL CMOS ANALOG VOLTAGE COMPARATOR

GENERAL DESCRIPTION

The ALD2321A/ALD2321B/ALD2321 is a monolithic Precision Dual Voltage Comparator, each having integrated dual complementary output drivers. It is constructed using advanced silicon gate CMOS technology. Key features of the ALD2321A/ALD2321B/ALD2321 include very high input impedance, very low offset voltage utilizing on-chip e-trim (EPAD® electronic-trimming) technology, flexible multiple output configurations and fast response time with small overdrive voltage. It is designed for ultra low level signal detection from high impedance sources. For many applications the ALD2321A/ALD2321B/ALD2321 can eliminate an input amplification stage, a precision input bias stage, a signal level shift stage and an output buffer stage, and do the entire job from low level input signal detection to high output driver -- all on a single chip.

The input voltage includes ground, making this voltage comparator ideal for single supply (+5V) or dual supply ($\pm 5V$) powered systems. For dual supply applications, GND pin is connected to the most negative supply instead of Ground (0.0V). The negative supply voltage can be at any value between 0.0V and -5V. Each voltage comparator is individually trimmed at the factory for minimum offset voltage at ground voltage potential, making the ALD2321A/ALD2321B/ALD2321 at its best offset voltage and ready to compare very low signal level voltages at or near ground potential. Typically a signal less than 1mV can be resolved and detected reliably without requiring amplification. Sensor or detector signals with signal power as low as 0.004pW (4×10^{-15} Watt) can be readily detected.

Each voltage comparator has two complementary output pins, one for Source Output (OUT_H) and the other for Sink Output (OUT). This dual complementary output allows maximum circuit design flexibility. The outputs can be used as Single-Ended Driver, Multiple WIRED-OR Outputs, Push-Pull Outputs or Complementary Outputs. The Sink Output can be used as an open drain output, which has current sink capability of up to 50mA. It can also be connected to an external voltage higher or lower than V+, which provide level shift of the output swing levels from other than V+ to GND. The Source Output can source up to 2mA and can be used to drive the base terminal of an external NPN bipolar device or the gate of a N-channel MOSFET device. Alternatively, the two outputs, Source Output and

ORDERING INFORMATION ("L" suffix for lead free version)

Operating Temperature Range *		
0°C to +70°C	0°C to +70°C	-55°C to +125°C
16-Pin Small Outline Package (SOIC)	16-Pin Plastic Dip Package	16-Pin CERDIP Package
ALD2321ASCL	ALD2321APCL	ALD2321ADC
ALD2321BSCL	ALD2321BPCL	ALD2321BDC
ALD2321SCL	ALD2321PCL	ALD2321DC

* Contact factory for leaded (non-RoHS) or high temperature versions.

FEATURES

- Ultra low signal power of 4fW detectable
- Ultra low offset voltage of max. 0.2mV
- Ultra low input bias currents of typ. 0.01pA
- Low supply current of 110µA typical
- Virtually eliminates source impedance effects
- Low operating supply voltage of 4V to 10V
- Single (+5V) and dual supply ($\pm 5V$) operation
- High speed for both small and large level signals 300ns typical for TTL inputs
- CMOS, NMOS and TTL compatible
- Each comparator has separate push and pull outputs
- High output sink current - typically 50mA
- Low supply current spikes
- Fanout of 30 TTL loads

APPLICATIONS

- Dual limit window comparator
- Power supply voltage monitor
- Photo-detector sensor circuit
- Relay or LED driver
- Oscillators
- Battery operated instruments
- Remote signal detection

PIN CONFIGURATION

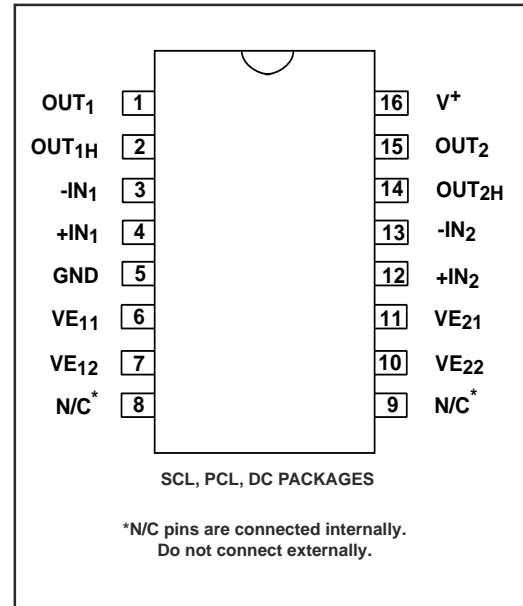

GENERAL DESCRIPTION (cont'd)

Sink Output, can be connected together to form a push-pull output which has the combined output capabilities of both channels.

In the dual complementary output mode, each comparator can be used to drive separate loads. Due to the complementary nature of the two outputs, only one output is active at any a given time, except for a limited crossover time. When OUT (sink output) is active ON, the OUT pin is sinking current and the OUT_H pin is OFF and in high impedance mode. Conversely, if OUT_H pin is ON and sourcing current, OUT pin is OFF. To configure push-pull output, simply connect OUT (sink output) pin to OUT_H pin.

Since each voltage comparator has its own complementary outputs, each comparator can be configured to have a different output type. For example, one comparator output can be connected as Open Drain output while the other comparator can be wired as push-pull output. If used to drive capacitive loads, the output DC current levels are at a very low level, at essentially leakage current levels, which can be a power saving feature.

The ALD2321A/ALD2321B/ALD2321 can detect and resolve very low voltage levels at high speed, with little or no overdrive voltage. Compared with other voltage comparator devices that require 100 mV overdrive voltages, or multiple stage circuits that include input preamp, etc., the ALD2321A/ALD2321B/ALD2321 can perform all input to output functions in one device with minimal delay time and with as low as a 1mV signal.

The ALD2321A/ALD2321B/ALD2321 is supplied with 4 external e-trim pins, VE11, VE12, VE21, and VE22. These pins are used for trimming of the voltage comparator offset voltages at the factory, and normally should be left open unconnected. However, in some cases these pins can be used as positive/negative feedback pins, since these pins have a positive/negative factor on the offset voltage. For example, see TYPICAL APPLICATIONS section titled "Voltage Comparator With Output Feedback to Provide Hysteresis."

In a printed circuit board layout, it is suggested that these pins, along with no connect (N/C) pins 8 and 9, be surrounded with ground traces to prevent any possible crosstalk and noise coupling from other signal sources.

Although not required for most applications, if necessary, small valued capacitors of approximately 1000pF can be mounted at these pins to ground to further reduce noise. For information on customized trimming under different biasing and power supply conditions, please contact factory.

BLOCK DIAGRAM

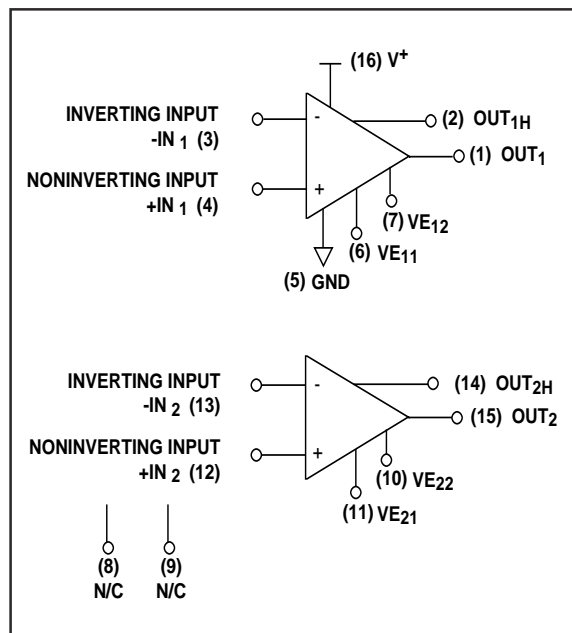

ALD2321 PIN IDENTIFICATION

PIN #	SYMBOL	FUNCTION	SIGNAL PROPAGATION
1	OUT ₁	COMPARATOR 1 SINK OUTPUT	OUTPUT
2	OUT _{1H}	COMPARATOR 1 SOURCE OUTPUT	OUTPUT
3	-IN ₁	COMPARATOR 1 INVERTING INPUT	INPUT
4	+IN ₁	COMPARATOR 1 NON-INVERTING INPUT	INPUT
5	GND	GROUND / V- SUPPLY	-
6	VE ₁₁	- VOS E-Trim COMPARATOR 1	INPUT
7	VE ₁₂	+ VOS E-Trim COMPARATOR 1	INPUT
8	N/C	No Connect/Do Not connect externally	-
9	N/C	No Connect/Do Not connect externally	-
10	VE ₂₂	+VOS E-Trim COMPARATOR 2	INPUT
11	VE ₂₁	- VOS E-Trim COMPARATOR 2	INPUT
12	+IN ₂	COMPARATOR 2 NON-INVERTING INPUT	INPUT
13	-IN ₂	COMPARATOR 2 INVERTING INPUT	INPUT
14	OUT _{2H}	COMPARATOR 2 SOURCE OUTPUT	OUTPUT
15	OUT ₂	COMPARATOR 2 SINK OUTPUT	OUTPUT
16	V+	V+ SUPPLY	-

ABSOLUTE MAXIMUM RATINGS

Supply voltage, V+	_____	+10.6V
Differential input voltage range	_____	-0.3V to V+ +0.3V
Power dissipation	_____	600 mW
Operating temperature range PCL, SCL packages	_____	0°C to +70°C
DC package	_____	-55°C to +125°C
Storage temperature range	_____	-65°C to +150°C
Lead temperature, 10 seconds	_____	+260°C

OPERATING ELECTRICAL CHARACTERISTICS

TA = 25°C V+ = +5V unless otherwise specified

Parameter	Symbol	2321A			2321B			2321			Unit	Test Conditions
		Min	Typ	Max	Min	Typ	Max	Min	Typ	Max		
Supply Voltage	V _S V+	±2 4		±5 10	±2 4		±5 10	±2 4		±5 10	V V	Dual Supply Single Supply
Supply Current Current	I _S		110	180		110	180		110	180	µA	No Load Two Comparators
Voltage Gain	A _{VD}	50	150		50	150		50	150		V/mV	R _{LOAD} ≥ 15K
Input Offset Voltage	V _{OS}		0.05	0.2		0.2	0.5		0.5	1.0	mV	R _{LOAD} ≥ 1.5KΩ
Input Offset Current ¹	I _{OS}		0.01	20		0.01	20		0.01	20	pA	
Input Bias Current ¹	I _B		0.01	20		0.01	20		0.01	20	pA	
Common Mode Input Voltage Range ²	V _{ICR}	-0.3		V+ -1.5	-0.3		V+ -1.5	-0.3		V+ -1.5	V	
Low Level Sink Output Voltage	V _{OL}		0.15	0.4		0.15	0.4		0.15	0.4	V	I _{SINK} = 12mA V _{INPUT} = 1V Differential
Low Level Sink Output Current	I _{OL}	24	50		24	50		24	50		mA	V _{OL} = 1.0 V SINK OUTPUT ON
High Level Source Output Voltage	V _{OH}	3.5	4.5		3.5	4.5		3.5	4.5		V	I _{SOURCE} = -2mA SOURCE OUTPUT ON
Source Output Leakage Current	I _{HL}		0.01	1		0.01	1		0.01	1	nA	V _{OH} = 0.0V SOURCE OUTPUT OFF
Sink Output Leakage Current	I _L		0.01	20		0.01	20		0.01	20	nA	V _{OUT} = 5.0 V SINK OUTPUT OFF
Response Time ²	t _{RP}		1.1			1.1			1.1		µs	R _L = 5.1KΩ, C _L = 15pF 5mV Input Step/ 0mV Overdrive
	t _{RP}		2.4			2.4			2.4		µs	R _L = 5.1KΩ, C _L = 15pF 1mV Input Step/ 0mV Overdrive
Common Mode Rejection Ratio	CMRR		80			80			80		dB	V _{INPUT} = 0V to 2.5V
Power Supply Rejection Ratio	PSRR		75			75			75		dB	V+ = 4V to 5V
Change of Vos / V _{Exx}	$\frac{\Delta V_{OS}}{\Delta V_E}$		5			5			5		mV/V	V _E pins No Load

Notes: ¹ Consists of junction leakage currents

² Sample test parameter

TYPICAL PERFORMANCE CHARACTERISTICS

SUPPLY CURRENT vs. TEMPERATURE

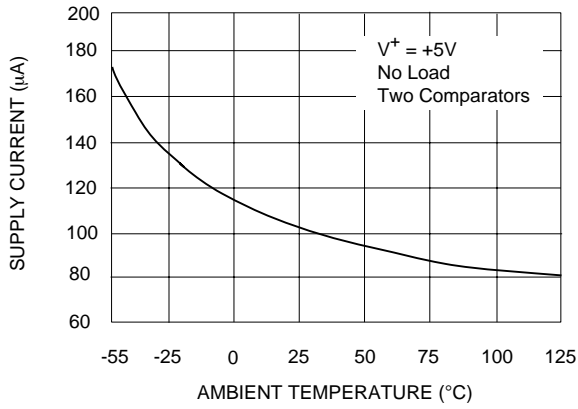

SUPPLY CURRENT vs. SUPPLY VOLTAGE

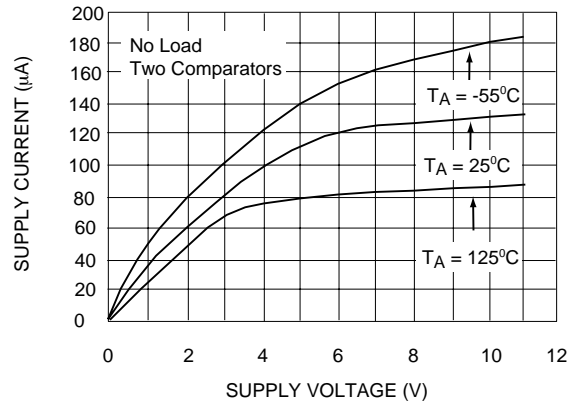

INPUT BIAS CURRENT vs. TEMPERATURE

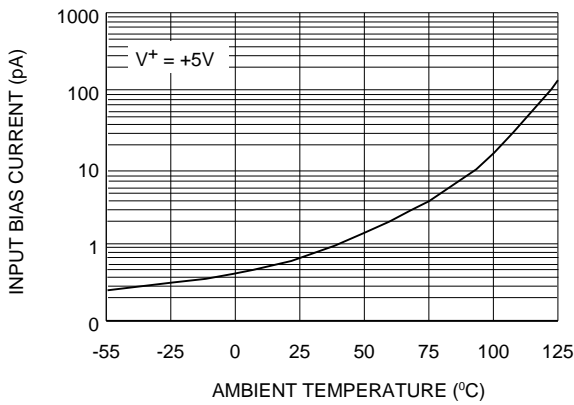

LOW LEVEL OUTPUT VOLTAGE vs. TEMPERATURE

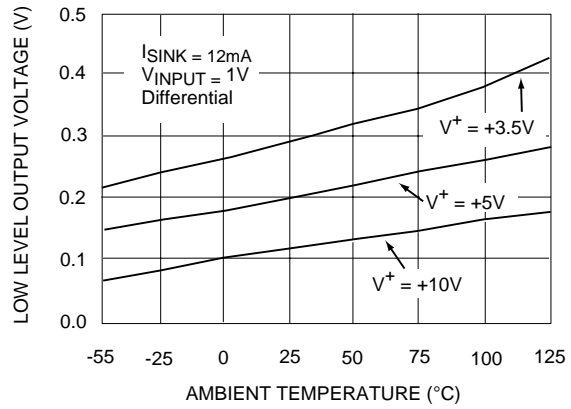

SATURATION VOLTAGE vs. SINK CURRENT

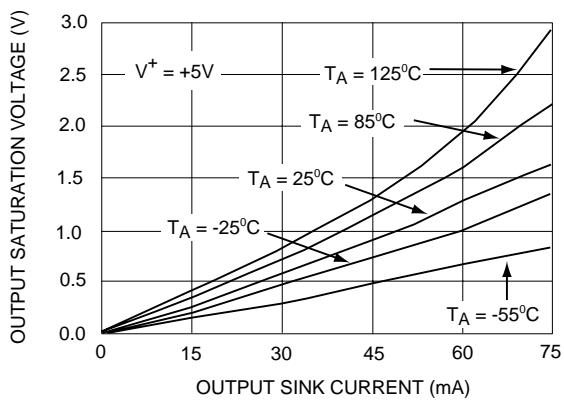

HIGH LEVEL OUTPUT VOLTAGE vs. HIGH LEVEL OUTPUT LEAKAGE CURRENT

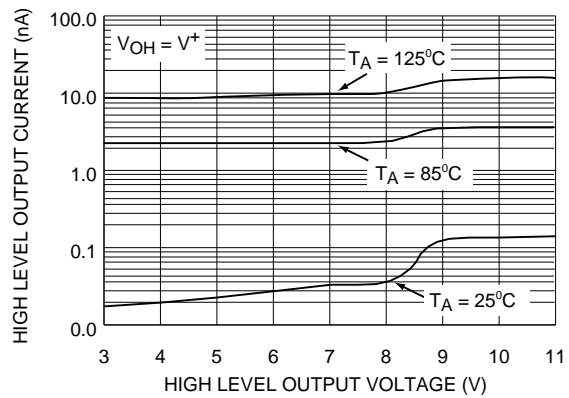

TYPICAL PERFORMANCE CHARACTERISTICS (cont'd)

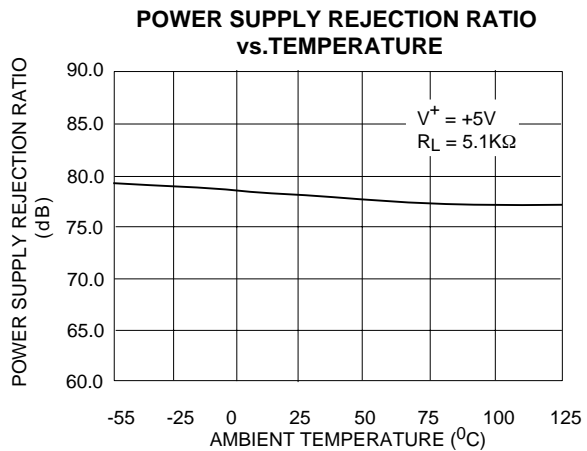
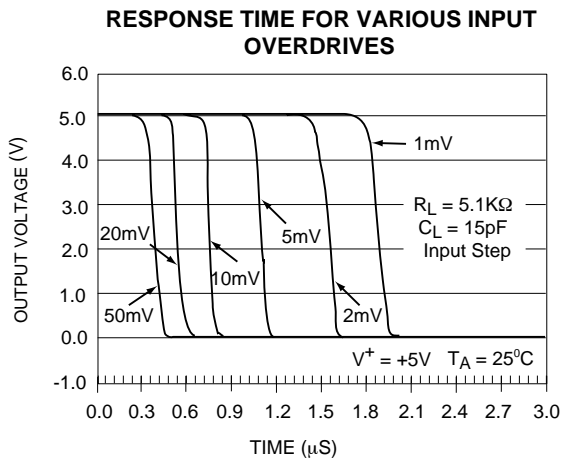
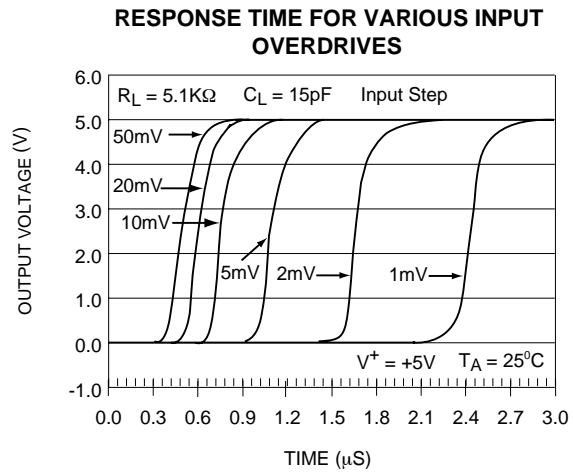
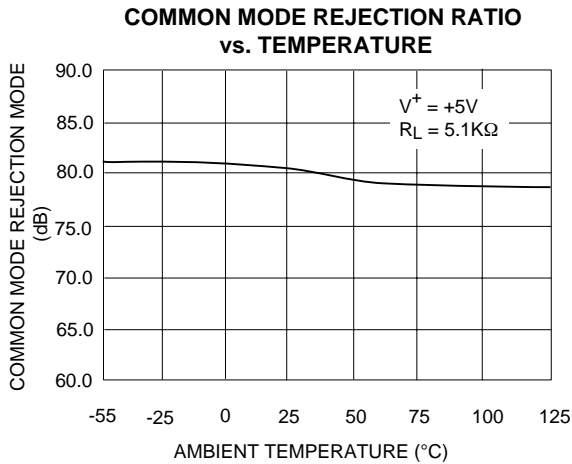
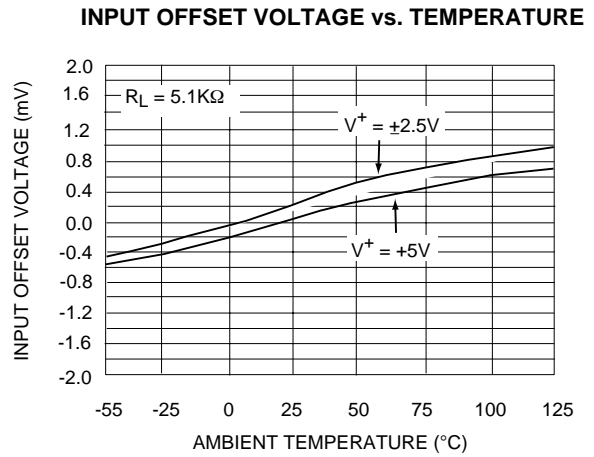
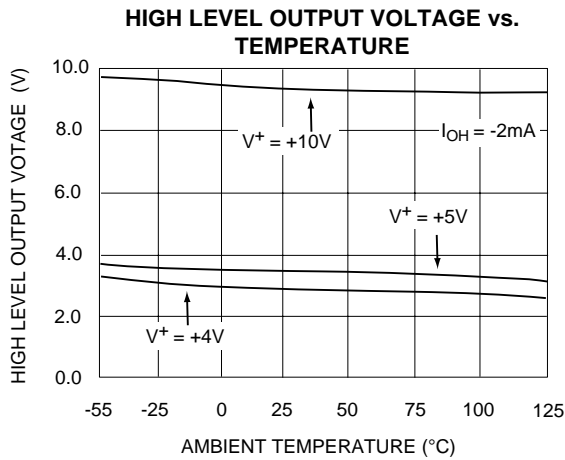

TYPICAL PERFORMANCE CHARACTERISTICS (cont'd)

TRANSFER FUNCTION

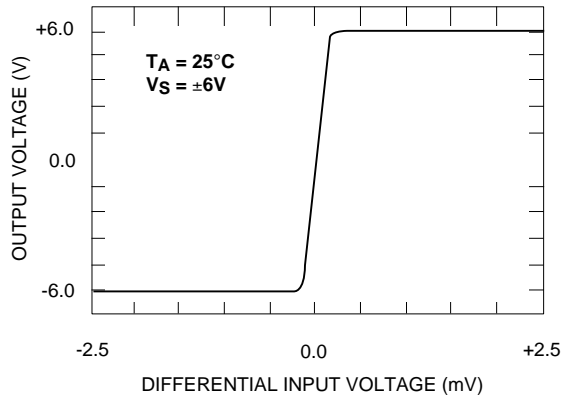

COMMON - MODE VOLTAGE REFERRED TO SUPPLY VOLTAGE

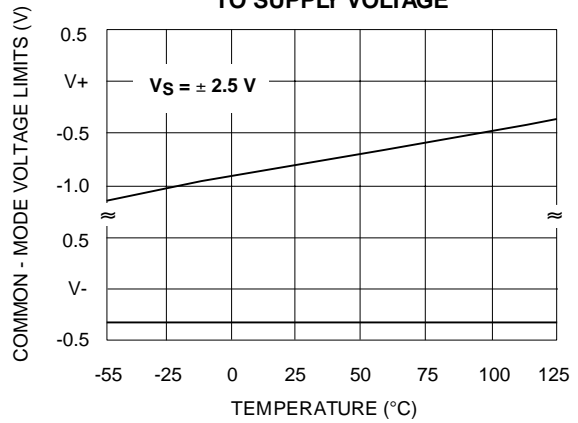

OUTPUT HIGH VOLTAGE vs. SUPPLY VOLTAGE

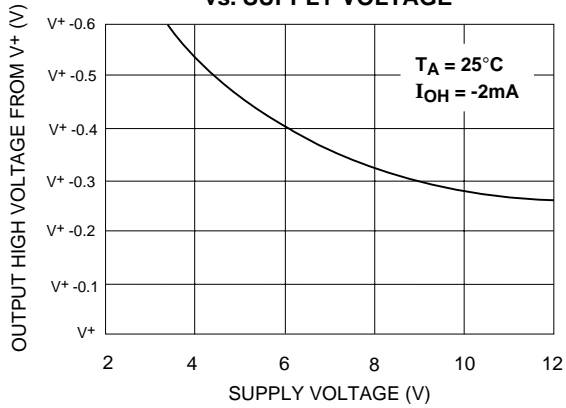

OUTPUT LOW VOLTAGE vs. SUPPLY VOLTAGE

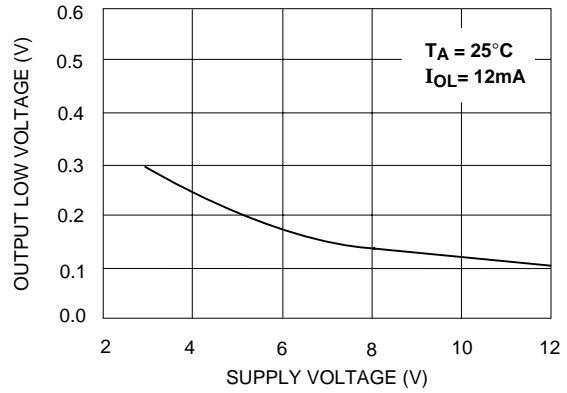

TYPICAL APPLICATIONS

PRECISION SINGLE SUPPLY VOLTAGE COMPARATOR WITH DIRECT RELAY DRIVER

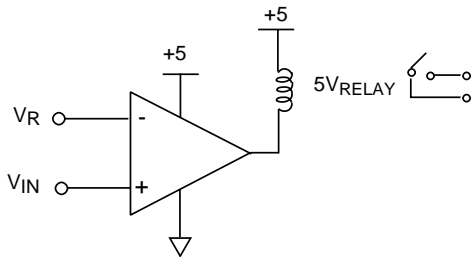

VOLTAGE COMPARATOR WITH +/-5V SUPPLY AND +5V RELAY DRIVE

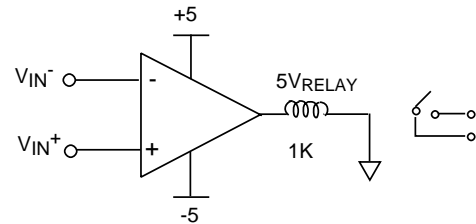

TYPICAL APPLICATIONS (cont'd)

VOLTAGE COMPARATOR WITH COMPLEMENTARY OUTPUT DRIVERS

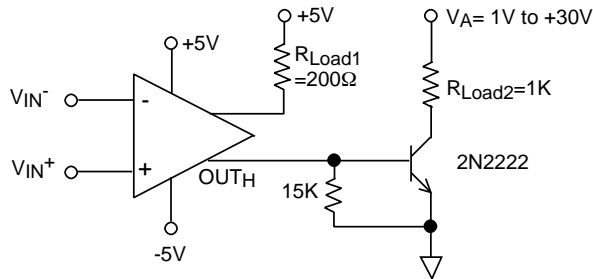

VOLTAGE COMPARATOR WITH OUTPUT FEEDBACK TO PROVIDE HYSTERESIS

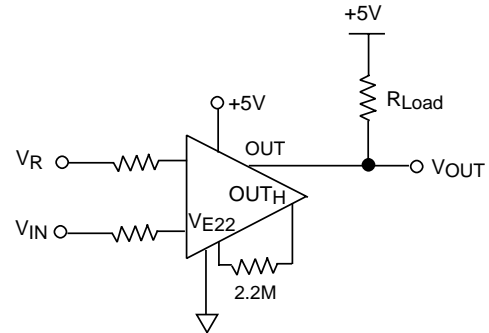

VOLTAGE COMPARATOR WITH +/-5V SUPPLY AND OUTPUT LEVEL SHIFT

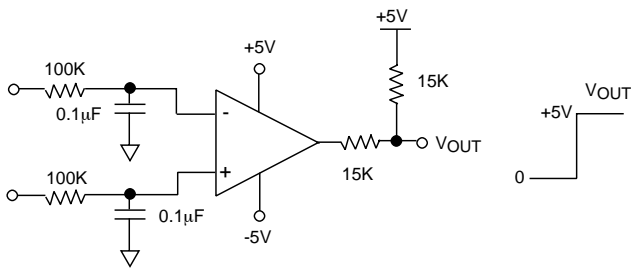

VOLTAGE COMPARATOR WITH OUTPUT LEVEL SHIFT AND HIGH CURRENT LOAD DRIVER

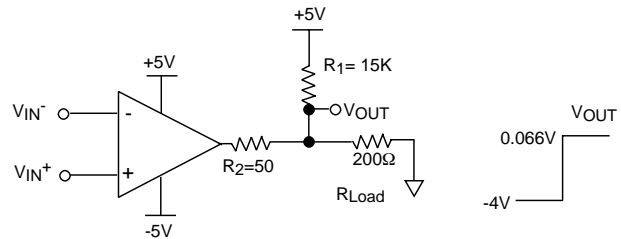

VOLTAGE COMPARATOR WITH SINGLE SUPPLY AND OUTPUT LEVEL SHIFT

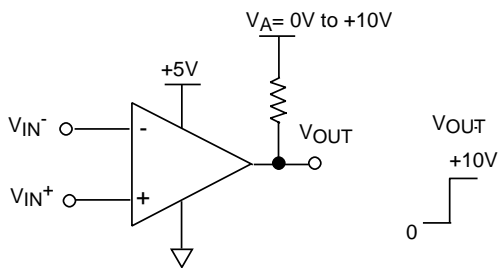

VOLTAGE COMPARATOR WITH COMPLEMENTARY OUTPUTS

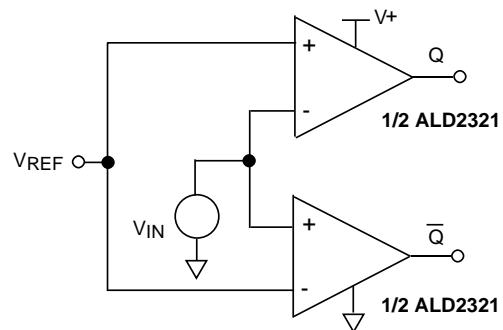

TYPICAL APPLICATIONS (cont'd)

DUAL LIMIT WINDOW COMPARTOR

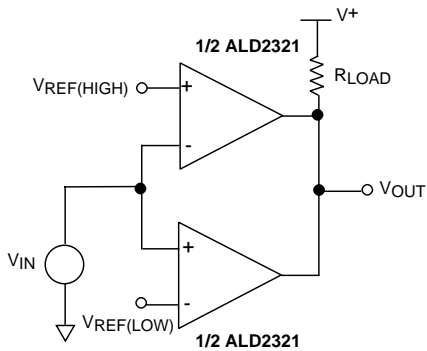

$R_{LOAD} = 1.5K\Omega$
 OUTPUT HIGH FOR $V_{IN} < V_{REF(HIGH)}$
 AND $V_{IN} > V_{REF(LOW)}$

DUAL LIMIT PHOTO DETECTOR MONITOR

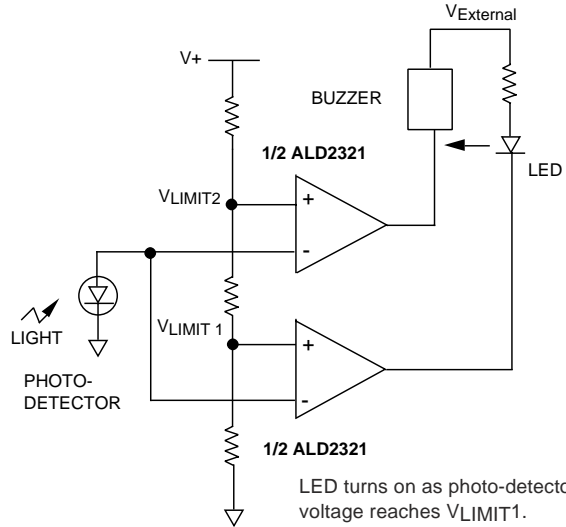

LED turns on as photo-detector voltage reaches V_{LIMIT1} .
 Both LED and horn turns on as photo-detector voltage reaches V_{LIMIT2} .
 $V_{EXTERNAL} = +12V$, $V+ = +5V$

RESPONSE TIME MEASUREMENT CIRCUIT

Response time is defined as the interval between the application of an input step function and the instant when the output reaches 50% of its maximum value as measured by the following test circuit:

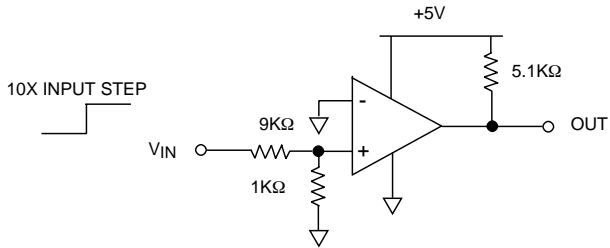

PINS OUT1, OUT1H, OUT2, OUT2H, INTERNAL CIRCUIT CONFIGURATIONS

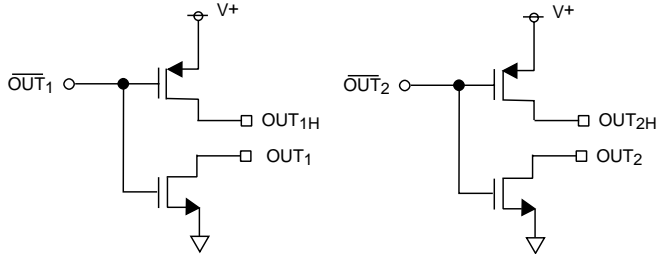

E-TRIM CIRCUIT

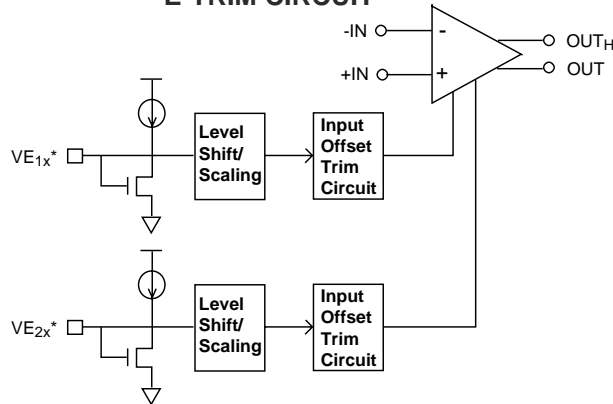

* These pins should be isolated by surrounding them with ground trace in user's applications.

SOIC-16 PACKAGE DRAWING

16 Pin Plastic SOIC Package

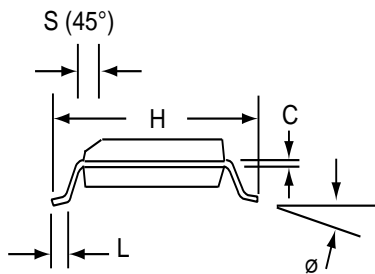
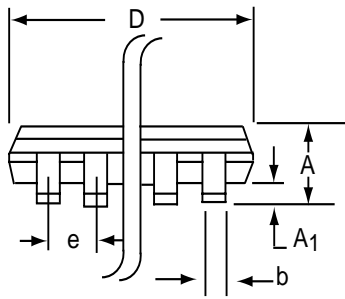
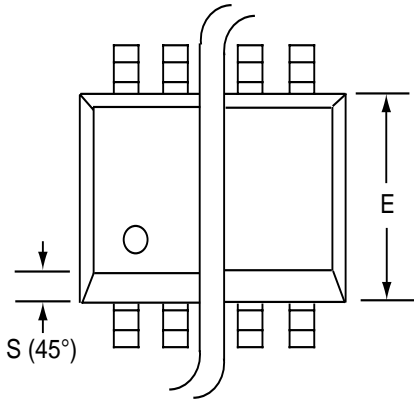

Dim	Millimeters		Inches	
	Min	Max	Min	Max
A	1.35	1.75	0.053	0.069
A₁	0.10	0.25	0.004	0.010
b	0.35	0.45	0.014	0.018
C	0.18	0.25	0.007	0.010
D-16	9.80	10.00	0.385	0.394
E	3.50	4.05	0.140	0.160
e	1.27 BSC		0.050 BSC	
H	5.70	6.30	0.224	0.248
L	0.60	0.937	0.024	0.037
∅	0°	8°	0°	8°
S	0.25	0.50	0.010	0.020

PDIP-16 PACKAGE DRAWING

16 Pin Plastic DIP Package

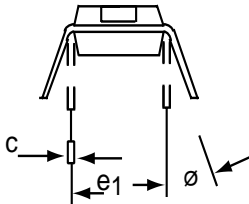
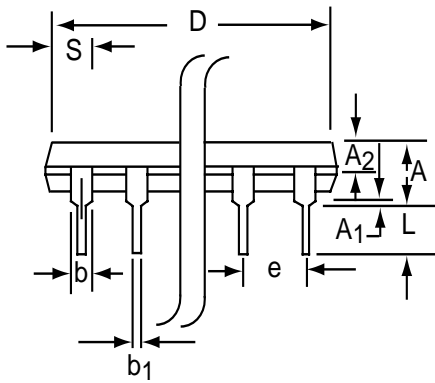
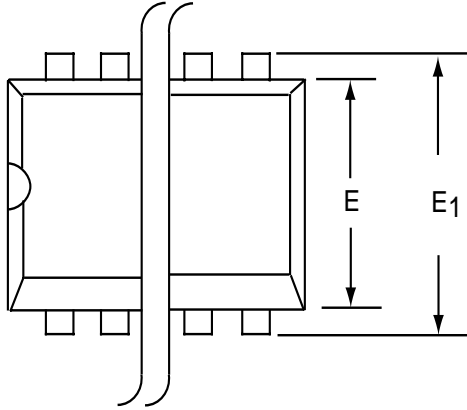

Dim	Millimeters		Inches	
	Min	Max	Min	Max
A	3.81	5.08	0.105	0.200
A₁	0.38	1.27	0.015	0.050
A₂	1.27	2.03	0.050	0.080
b	0.89	1.65	0.035	0.065
b₁	0.38	0.51	0.015	0.020
c	0.20	0.30	0.008	0.012
D-16	18.93	21.33	0.745	0.840
E	5.59	7.11	0.220	0.280
E₁	7.62	8.26	0.300	0.325
e	2.29	2.79	0.090	0.110
e₁	7.37	7.87	0.290	0.310
L	2.79	3.81	0.110	0.150
S-16	0.38	1.52	0.015	0.060
ø	0°	15°	0°	15°

CERDIP-16 PACKAGE DRAWING

16 Pin CERDIP Package

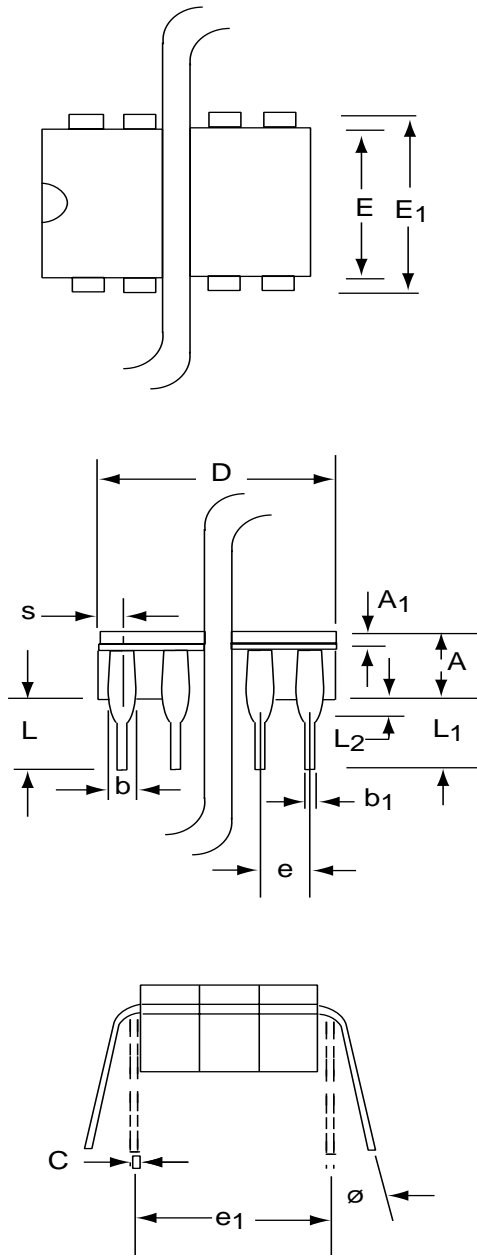

Dim	Millimeters		Inches	
	Min	Max	Min	Max
A	3.55	5.08	0.140	0.200
A₁	1.27	2.16	0.050	0.085
b	0.97	1.65	0.038	0.065
b₁	0.36	0.58	0.014	0.023
C	0.20	0.38	0.008	0.015
D-16	--	21.34	--	0.840
E	5.59	7.87	0.220	0.310
E₁	7.73	8.26	0.290	0.325
e	2.54 BSC		0.100 BSC	
e₁	7.62 BSC		0.300 BSC	
L	3.81	5.08	0.150	0.200
L₁	3.18	--	0.125	--
L₂	0.38	1.78	0.015	0.070
S	--	2.49	--	0.098
∅	0°	15°	0°	15°