

## EVC 500 Main Contactor

- Limiting continuous current 500A at 85°C (with 400mcm conductors)
- Hermetically sealed
- UL approved

### Typical applications

- DC high voltage high current applications
- Main contactors for hybrid, full battery electric vehicles and fuel-cell cars
- Battery charging systems



3D500\_fw5

### Contact Data

Contact arrangement	1 Form X (SPST NO DM)
Rated operating voltage	450VDC (450-900VDC) <sup>1)</sup>
Continuous carry current <sup>2)</sup>	500A
85°C, load cable 214mm <sup>2</sup> /400mcm	
Limiting short-time current	
85°C, load cable 107mm <sup>2</sup> /200mcm	500A / 7.5min 1000A / 1min 2000A / 15s
Make/break current at various voltages	see graph on page 3
Limiting break current, forward direction resistive load, 23°C, 450VDC	1 x 1560A
Load life	see graph on page 3
Initial contact voltage drop at 200A, 30s	<100mV
Operate / release time max.	
close (includes bounce)	20 <sup>3)</sup>
bounce (after close only)	7
release (includes arcing) at 2000A	12
Mechanical life	>500,000 cycles

- 1) Suitable for voltages up to 450VDC with limited capability to 900VDC.
- 2) Maximum allowed terminal temperatures are: 150°C continuous; 175°C for 2h; 200°C for 2min.
- 3) 20ms (max.) at rated 12V. Consult TE Connectivity for operating time not done at rated voltage.

### Coil Data<sup>4)</sup>

#### Economized coil with internal economizer (valid from -40°C to 85°C)

Coil code	Operating voltage range VDC	Inrush current at 23°C A	Max. inrush time ms	Nominal frequency kHz	Nominal duty cycle %
A	9 to 36	3.8	130	19.9	20

#### Un-economized coil for external economization<sup>5)</sup>

Coil code	Rated voltage VDC	Pull-in voltage min. VDC	Pull-in voltage max. VDC	Drop-out voltage max. VDC	Drop-out voltage min. VDC	Min. hold current mA	Coil resistance Ω -5%/+10%
1	12	4.2	6.5	1.5	0.5	650 <sup>6)</sup>	3.14

- 4) All data valid at 23°C coil temperature.
- 5) Un-economized coil must be economized by the customer to avoid overheating.
- 6) Must operate at 12V for 100ms before reducing to minimum holding current.

### Coil Data (continued)

#### Recommended PWM parameters for customer supplied economizer circuit (valid from -40°C to 85°C)

Frequency kHz	Operating voltage range VDC	Coil Current (min. recommended RMS) mA	Duty cycle %	Max. inrush time ms
16 to 20	8.5 to 16	650	20 to 30	200

### Insulation Data

Initial dielectric strength <sup>7)</sup>		
between open contacts		2920VDC/leakage <1mA
between contact and coil		2920VDC/leakage <1mA
max. altitude		5000m
Insulation resistance at 500VDC <sup>7)</sup>		
between open contacts		>1 GΩ
between contact and coil		>1 GΩ

- 7) Meets dielectric strength and IR requirements according to ISO 6469-3, conformity to IEC60664-1 in preparation.

### Other Data

Material data	
EU RoHS/ELV compliant	
Ambient temperature	-40°C to +85°C
Vibration resistance (functional)	
sine sweep/peak	80-2000Hz/20g
Shock resistance (functional)	
coil energized, peak	50g
Terminal type	stripped wires (coil) and screw (load)
Weight	approx. 430g (0.95lb)

### Terminal Assignment

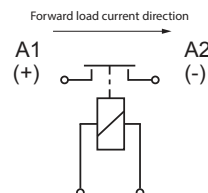

## EVC 500 Main Contactor (Continued)

### Dimensions

EVC 500 main contactor without coil economizer

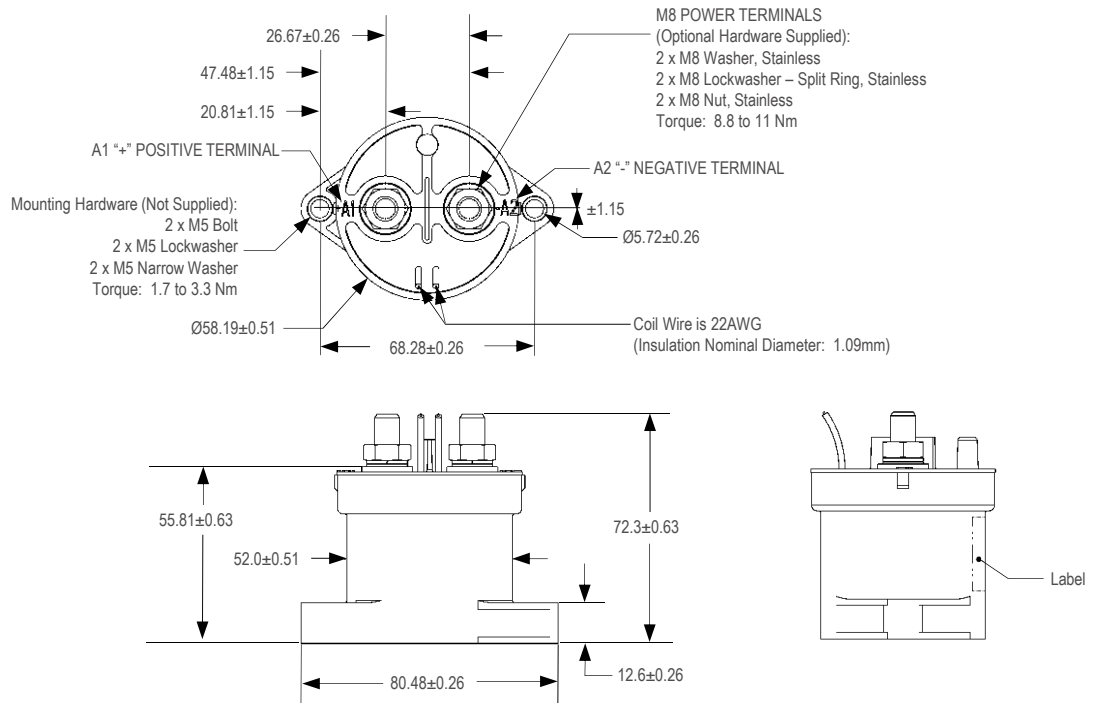

### Dimensions

EVC 500 main contactor with internal economizer

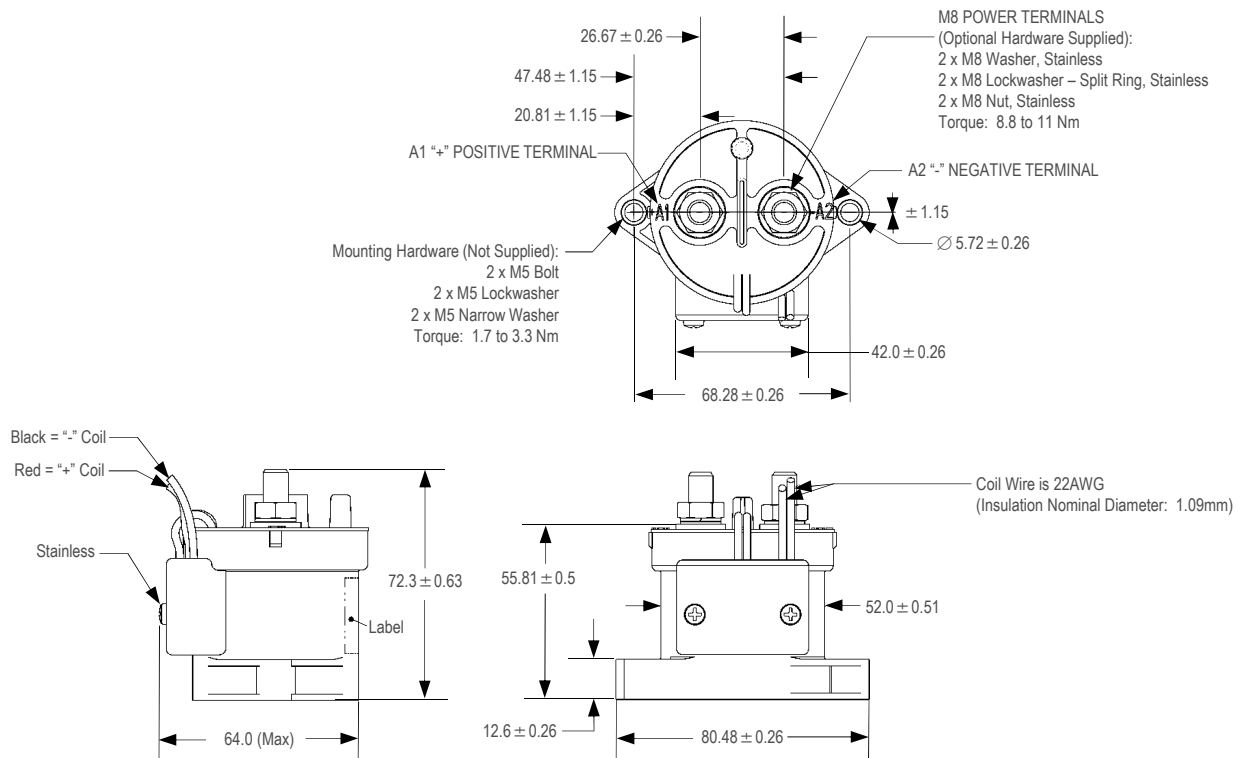

## EVC 500 Main Contactor (Continued)

### Contact performance

Estimated make and break power switching ratings (forward direction)

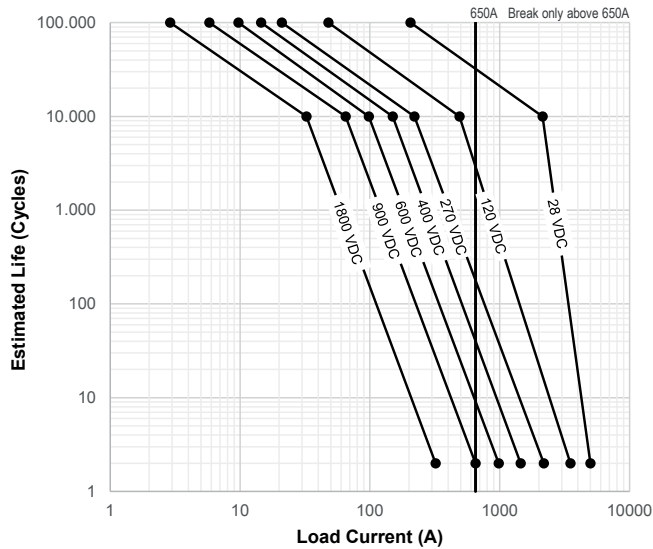

**Notes:**

- 1) Maximum of 300µH for resistive load. Consult TE Connectivity for inductive loads.
- 2) Estimates based on extrapolated data. Consult TE Connectivity to confirm performance in application.
- 3) End of life when "Insulation Resistance" between terminals falls below 50 MΩ at 500VDC.
- 4) The maximum make current is 650A to avoid contact welding.
- 5) Curves for voltages above maximum rated voltage for information purpose only.
- 6) For reverse current switching capability, please contact TE Connectivity for details.

Contacts closed into capacitor precharge sequence at various time constants

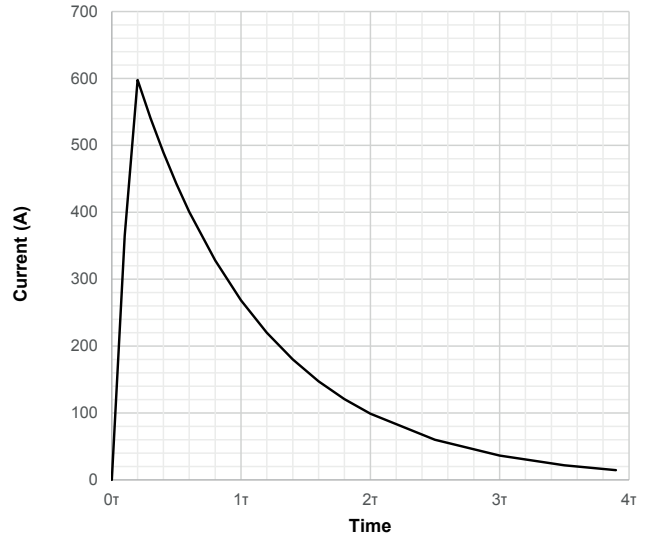

**Notes:**

- 1) Because higher current cause more damage to contact surface, at least 95% precharge recommended.
- 2) Inrush current dependent upon RC time constant and precharge timing sequence.

Estimated fuse guide for EVC 500 contactors  
(Reference only – not to be used for actual fuse sizing)

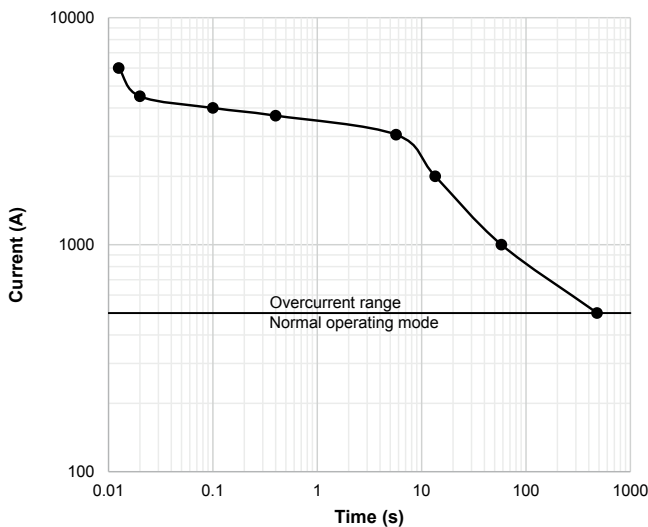

### Coil inductance

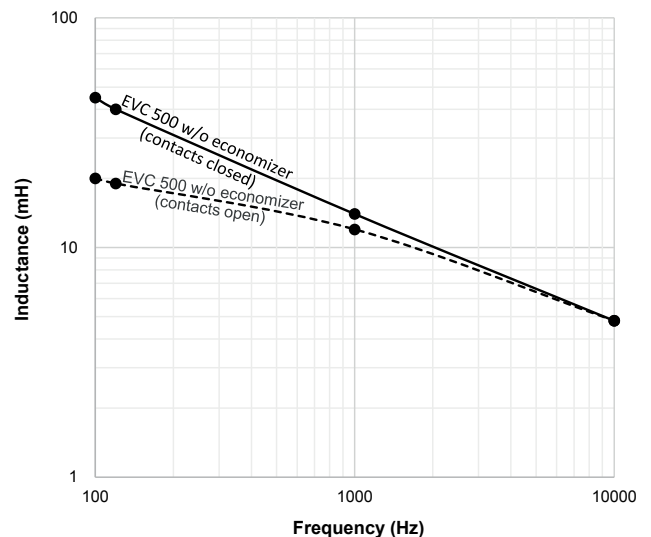

**Note:**

Data points above were measured using Quadtech 1715 LCR Bridge set 10Ω range, 1V output, measured at 100Hz, 120Hz, 1kHz and 10kHz.

## EVC 500 Main Contactor (Continued)

<b>Product code structure</b>	Typical product code						<b>EVC 500</b>	<b>-A</b>	<b>1</b>	<b>-A</b>	<b>N</b>	<b>A</b>	<b>M</b>
<b>Type</b>	<b>EVC 500</b> EVC 500 Main Contactor												
<b>Contact arrangement</b>	<b>A</b> SPST-NO-DM												
<b>Coil system</b>	<b>1</b> 12VDC (requires external economizer)						<b>A</b> 12VDC (internal economizer)						
<b>Coil wire length</b>	<b>A</b> 15.3 inches (390mm)												
<b>Coil termination</b>	<b>N</b> None – stripped wires						<b>C</b> Customer specific connector						
<b>Mounting &amp; power terminals</b>	<b>A</b> Bottom mount & male 10mm x M8 terminals												
<b>Connection hardware (power terminals)</b>	<b>M</b> Connection hardware included						<b>N</b> No connection hardware included						

### Production in Americas (only)

Product code	Contact arrang.	Coil	Circuit	Coil suppr.	Relay Type	Resistance	Part number
EVC 500-A1ANAM	SPDT-NO-DM	12VDC	No economizer	External >40V	450VDC	3.14Ω	2098372-1
EVC 500-AAANAM			Internal PWM	Internal			2098190-1

### Production in AP (Korea only)

Product code	Contact arrang.	Coil	Circuit	Coil suppr.	Relay Type	Resistance	Part number
EVC 500-A1ANAM	SPDT-NO-DM	12VDC	No economizer	External >40V	450VDC	3.14Ω	2219561-1
EVC 500-AAANAM			Internal PWM	Internal			2299223-2

### Production in AP (China only)

Product code	Contact arrang.	Coil	Circuit	Coil suppr.	Relay Type	Resistance	Part number
EVC 500-A1ANAM	SPDT-NO-DM	12VDC	No economizer	External >40V	450VDC	3.14Ω	2327585-1
EVC 500-AAANAM			Internal PWM	Internal			2303096-2
EVC 500-AAACAM-01			Internal PWM with connector	Internal			2303096-1