

DESIGNED AND DIMENSIONED IN MILLIMETERS [INCHES]

ERM5-XXX-XX.X-X-DV-XX-X-XR

DO NOT SCALE FROM THIS PRINT

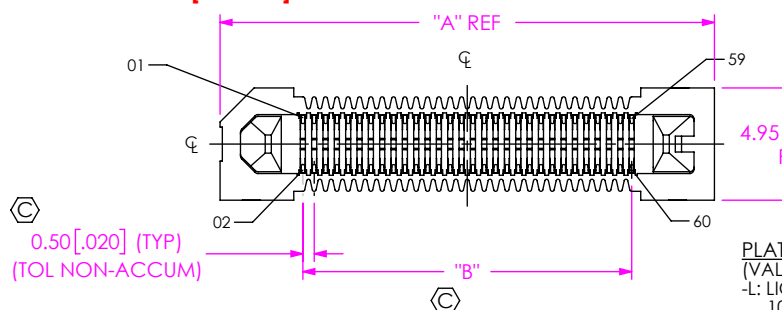

No. OF POSITIONS (PER ROW)

-005, -010, -020, -030, -040, -050, -060, -070, -075

LEAD STYLE

-02.0 = 2MM
-04.0 = 4MM
-05.0 = 5MM

TAPE & REEL (SEE NOTES 4, 5 & 6)

-TR: TAPE & REEL
-FR: FULL REEL QTY TAPE & REEL

PICK & PLACE OPTION

-K: POLYIMIDE FILM PAD (SEE NOTE 6) (NOT AVAILABLE FOR -005 POSITION)

-P: PICK AND PLACE PAD (PPP-08 ONLY AVAILABLE FOR -020 THRU -075 POSITIONS) (PPP-89 ONLY AVAILABLE FOR -005 AND -010 POSITIONS)

PLATING SPECIFICATION (VALUES GIVEN ARE IN MICRO-INCHES)

-L: LIGHT SELECTIVE, 10 Au / 50 Ni MIN ON CONTACT, MATTE TIN TAIL

-S: SELECTIVE, 30 Au / 50 Ni MIN ON CONTACT, MATTE TIN TAIL

OPTIONS

-FL: FRICTION LOCK (NOT AVAILABLE WITH -WT, ONLY AVAILABLE UP TO 30 POSITIONS) (FOR MATING WITH ERF5-XXX-XX.X-X-DV-FL)

-WT: WELD TAB (NOT AVAILABLE WITH -FL) (FOR MATING WITH ERF5-XXX-XX.X-X-DV-WT)

-L: LATCH (NOT AVAILABLE WITH -FL OR -WT OPTIONS) (ONLY AVAILABLE WITH -020, -030, & -040 POSITIONS AND 02.0 & 05.0 LEAD STYLES)

ROW SPECIFICATION

-DV: DOUBLE VERTICAL

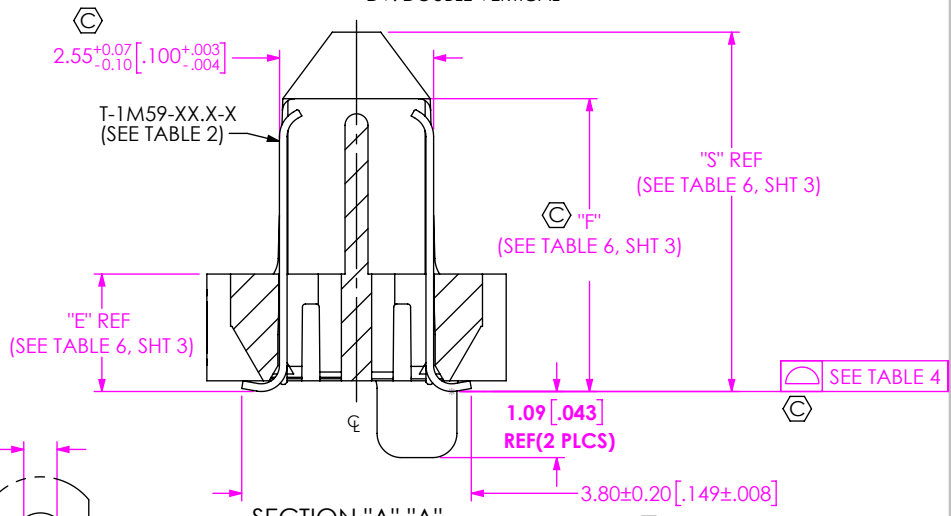
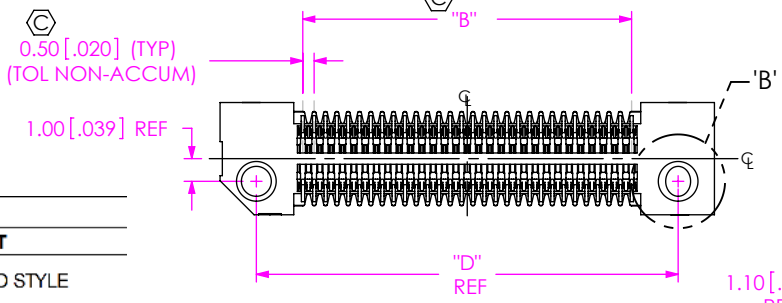
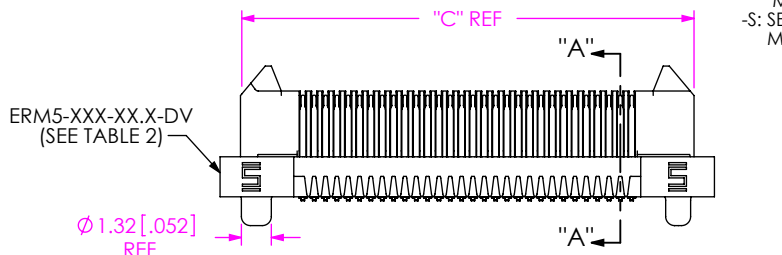

TABLE 1 REF STACK HEIGHT

ERM5 LEAD STYLE	ERF5 LEAD STYLE	
-05.0	-07.0	
-02.0	7.0MM	9MM
-05.0	10.0MM	12MM
-04.0	9.0MM	11MM

TABLE 2

LEAD STYLE	ERM5-XXX-XX.X-DV	T-1M59-XX.X-X
-02.0	ERM5-XXX-02.0-DV	T-1M59-02.0-X
-05.0	ERM5-XXX-05.0-DV	T-1M59-05.0-X
-04.0	ERM5-XXX-04.0-DV	T-1M59-04.0-X

TABLE 3

POSITION	"A"	"B"	"C"	"D"
-005	9.30 [0.366]	2.00 [0.079]	7.50 [0.295]	6.10 [0.240]
-010	11.80 [0.465]	4.50 [0.177]	10.00 [0.394]	8.60 [0.339]
-020	16.80 [0.661]	9.50 [0.374]	15.00 [0.591]	13.60 [0.535]
-030	21.80 [0.858]	14.50 [0.571]	20.00 [0.787]	18.60 [0.732]
-040	26.80 [1.055]	19.50 [0.768]	25.00 [0.984]	23.60 [0.929]
-050	31.80 [1.252]	24.50 [0.965]	30.00 [1.181]	28.60 [1.126]
-060	36.80 [1.449]	29.50 [1.161]	35.00 [1.378]	33.60 [1.323]
-070	41.80 [1.646]	34.50 [1.358]	40.00 [1.575]	38.60 [1.520]
-075	44.30 [1.744]	37.00 [1.457]	42.50 [1.673]	41.10 [1.618]

TABLE 4

No. OF POS.	
-005, -010, -020, -030, -040	0.10 [0.004]
-050, -060, -070, 075	0.13 [0.005]

DETAIL 'B' SCALE 4 : 1

NOTES:

- ⊙ REPRESENTS A CRITICAL DIMENSION.
- MAXIMUM BURR ALLOWANCE: 0.038[.0015]
- MINIMUM PUSHOUT FORCE: 1.6 N [.36 LB.]
MINIMUM WELD TAB PUSHOUT FORCE, -04.0 & -05.0 LEAD STYLES: 2.25 N [.51 LB.]
-02.0 LEAD STYLE: 1.45 N [.33 LB.]
- ORDERS WILL BE PACKAGED ACCORDING TO THE SAMTEC PACKAGING EFFICIENCY STANDARDS (SPES) FOUND ON WWW.SAMTEC.COM.
- ATTACH LABEL TO EACH REEL.
- LEAD STYLE -02.0 WITH -K-TR OPTIONS AVAILABLE TO EXISTING CUSTOMERS ONLY.

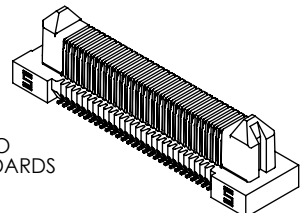

UNLESS OTHERWISE SPECIFIED, DIMENSIONS ARE IN MILLIMETERS [INCHES].

TOLERANCES ARE:

DECIMALS ANGLES

X.X: ±0.3 [.01]
X.XX: ±0.13 [.005]
X.XXX: ±0.050 [.0020]

PROPRIETARY NOTE

THIS DOCUMENT CONTAINS CONFIDENTIAL AND PROPRIETARY INFORMATION AND ALL DESIGN, MANUFACTURING, REPRODUCTION, USE, PATENT RIGHTS AND SALES RIGHTS ARE EXPRESSLY RESERVED BY SAMTEC, INC. THIS DOCUMENT SHALL NOT BE DISCLOSED, IN WHOLE OR PART, TO ANY UNAUTHORIZED PERSON OR ENTITY NOR REPRODUCED, TRANSFERRED OR INCORPORATED IN ANY OTHER PROJECT IN ANY MANNER WITHOUT THE EXPRESS WRITTEN CONSENT OF SAMTEC, INC.

samtec

520 PARK EAST BLVD. NEW ALBANY, IN 47150
PHONE: 812-944-6733 FAX: 812-948-5047
e-Mail info@SAMTEC.com code 55322

DESCRIPTION:
.5MM EDGE RATE TERMINAL ASSEMBLY

DWG. NO.
ERM5-XXX-XX.X-X-DV-XX-X-XR

BY: DAVID W 4/30/2008 SHEET 1 OF 4

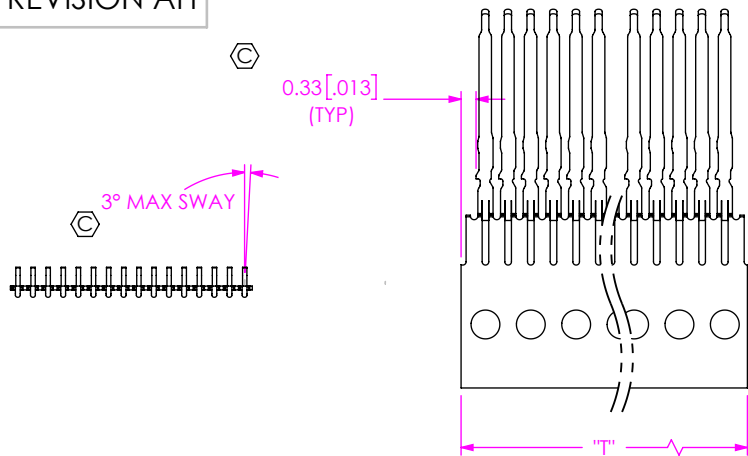

TABLE 9

POSITION	"T"
-005	3.00 [0.118]
-010	5.50 [0.216]
-020	10.50 [0.413]
-030	15.50 [0.610]
-040	20.50 [0.807]
-050	25.50 [1.004]
-060	30.50 [1.201]
-070	35.50 [1.398]
-075	38.00 [1.496]

IN PROCESS 1
CUT T-1M59-XX.X-X TERMINAL COMBS
(ALL TAILS SAME DIRECTION)

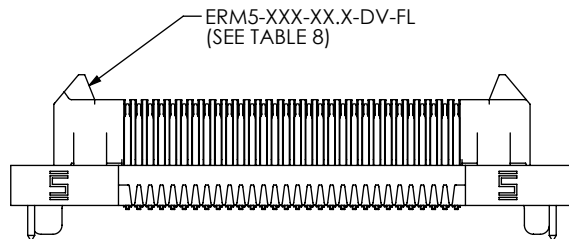

FIG 4
(ERM5-030-02.0-X-DV-WT-XR SHOWN)
(SAME AS FIG 3)
(NOT AVAILABLE WITH -FL)

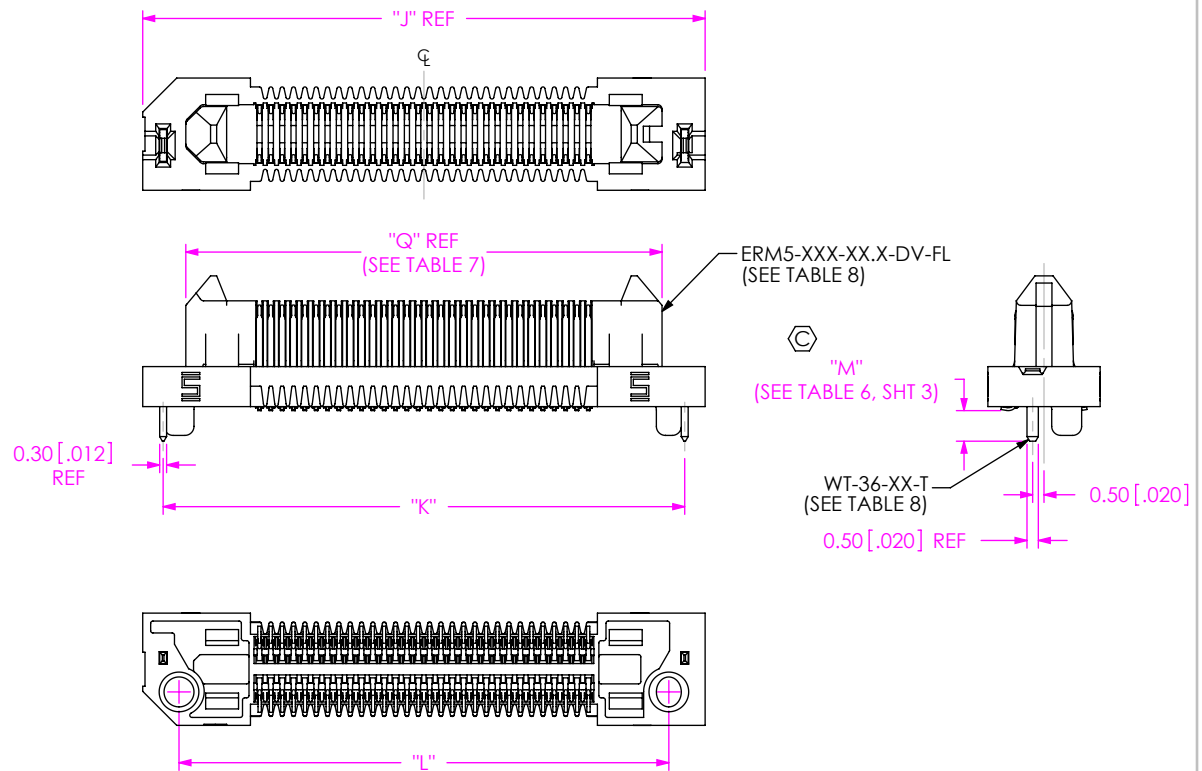

FIG 3
(ERM5-030-02.0-X-DV-FL-XR SHOWN)
(SAME AS FIG 1 EXCEPT AS SHOWN)
(NOT AVAILABLE WITH -WT, ONLY AVAILABLE UP TO 30 POSITIONS)

TABLE 7

POSITION	"J"	"K"	"L"	"Q"
-005	12.30 [0.484]	10.50 [0.413]	9.10 [0.358]	8.50 [0.335]
-010	14.80 [0.583]	13.00 [0.512]	11.60 [0.457]	11.50 [0.453]
-020	19.80 [0.780]	18.00 [0.709]	16.60 [0.654]	16.00 [0.630]
-030	24.80 [0.976]	23.00 [0.906]	21.60 [0.850]	21.00 [0.827]
-040	29.80 [1.173]	28.00 [1.102]	26.60 [1.047]	26.00 [1.024]
-050	34.80 [1.370]	33.00 [1.299]	31.60 [1.244]	31.00 [1.220]
-060	39.80 [1.567]	38.00 [1.496]	36.60 [1.441]	36.00 [1.417]
-070	44.80 [1.764]	43.00 [1.693]	41.60 [1.638]	41.00 [1.614]
-075	47.30 [1.862]	45.50 [1.791]	44.10 [1.736]	43.50 [1.713]

TABLE 8

LEAD STYLE	ERM5-XXX-XX.X-DV-XX	WT-36-XX-T
-02.0	ERM5-XXX-02.0-DV-FL	WT-36-05-T
-05.0	ERM5-XXX-05.0-DV-FL	WT-36-01-T
-04.0	ERM5-XXX-04.0-DV-FL	WT-36-06-T

PROPRIETARY NOTE
THIS DOCUMENT CONTAINS CONFIDENTIAL AND PROPRIETARY INFORMATION AND ALL DESIGN, MANUFACTURING, REPRODUCTION, USE, PATENT RIGHTS AND SALES RIGHTS ARE EXPRESSLY RESERVED BY SAMTEC, INC. THIS DOCUMENT SHALL NOT BE DISCLOSED, IN WHOLE OR PART, TO ANY UNAUTHORIZED PERSON OR ENTITY NOR REPRODUCED, TRANSFERRED OR INCORPORATED IN ANY OTHER PROJECT IN ANY MANNER WITHOUT THE EXPRESS WRITTEN CONSENT OF SAMTEC, INC.

DO NOT SCALE DRAWING

SHEET SCALE: 3:1



520 PARK EAST BLVD, NEW ALBANY, IN 47150
PHONE: 812-944-6733 FAX: 812-948-5047
e-Mail info@SAMTEC.com code 55322

DESCRIPTION:
.5MM EDGE RATE TERMINAL ASSEMBLY

DWG. NO.
ERM5-XXX-XX.X-X-DV-XX-X-XR

BY: DAVID W 4/30/2008 SHEET 2 OF 4

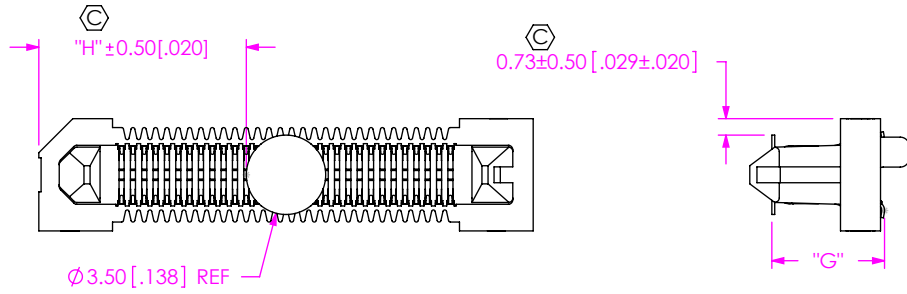

FIG 2
-K OPTION
(USE K-DOT-138-250-005)
(ERM5-030-02.0-X-DV-K SHOWN)

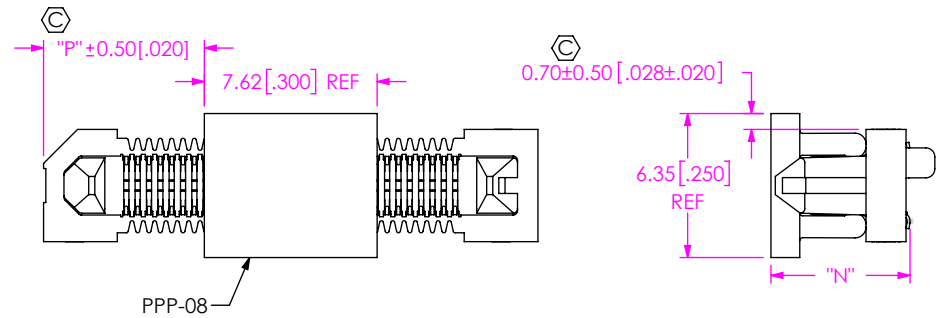

FIG 5
-P OPTION
(PPP-08 ONLY AVAILABLE FOR -020 THRU -075 POSITIONS)
(ERM5-030-02.0-X-DV-P-XR SHOWN)

TABLE 5

POSITION	"H"			"P"			"R"	
	-K	-WT-K	-FL-K	-P	-WT-P	-FL-P	-P	-WT-P
-005	2.90 [0.114]	4.40 [0.173]	4.40 [0.173]	-	-	-	2.90 [0.065]	4.40 [0.124]
-010	4.15 [0.163]	5.65 [0.222]	5.65 [0.222]	-	-	-	4.15 [0.163]	5.65 [0.222]
-020	6.65 [0.262]	8.15 [0.321]	8.15 [0.321]	4.59 [0.181]	6.09 [0.240]	6.09 [0.240]	-	-
-030	9.15 [0.360]	10.65 [0.419]	10.65 [0.419]	7.09 [0.279]	8.59 [0.338]	8.59 [0.338]	-	-
-040	11.65 [0.459]	13.15 [0.518]	-	9.59 [0.378]	11.09 [0.437]	-	-	-
-050	14.15 [0.557]	15.65 [0.616]	-	12.09 [0.476]	13.59 [0.535]	-	-	-
-060	16.65 [0.656]	18.15 [0.715]	-	14.59 [0.574]	16.09 [0.633]	-	-	-
-070	19.15 [0.754]	20.65 [0.813]	-	17.09 [0.673]	18.59 [0.732]	-	-	-
-075	20.40 [0.803]	21.90 [0.862]	-	18.34 [0.722]	19.84 [0.781]	-	-	-

TABLE 6

LEAD STYLE	"E"	"F"	"G"	"M"	"N"	"S"
-02.0	1.94 [0.076]	4.84 [0.191]	4.97 [0.196]	1.35 [0.053]	6.11 [0.241]	5.94 [0.234]
-05.0	4.94 [0.194]	7.84 [0.309]	7.97 [0.314]	1.40 [0.055]	9.11 [0.359]	8.94 [0.352]
-04.0	3.94 [0.155]	6.84 [0.269]	6.97 [0.274]	1.12 [0.044]	8.11 [0.319]	7.94 [0.313]

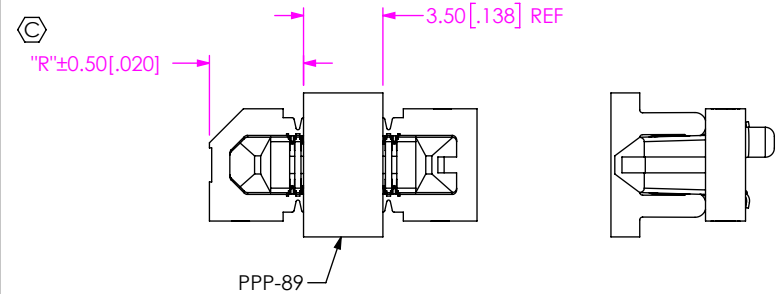

FIG 6
-P OPTION
(PPP-89 ONLY AVAILABLE FOR -005 AND -010 POSITIONS)
(ERM5-010-02.0-X-DV-P-XR SHOWN)
(DIFFERENT AS SHOWN, OTHERWISE SAME AS FIG 5)

PROPRIETARY NOTE

THIS DOCUMENT CONTAINS CONFIDENTIAL AND PROPRIETARY INFORMATION AND ALL DESIGN, MANUFACTURING, REPRODUCTION, USE, PATENT RIGHTS AND SALES RIGHTS ARE EXPRESSLY RESERVED BY SAMTEC, INC. THIS DOCUMENT SHALL NOT BE DISCLOSED, IN WHOLE OR PART, TO ANY UNAUTHORIZED PERSON OR ENTITY NOR REPRODUCED, TRANSFERRED OR INCORPORATED IN ANY OTHER PROJECT IN ANY MANNER WITHOUT THE EXPRESS WRITTEN CONSENT OF SAMTEC, INC.

DO NOT SCALE DRAWING

SHEET SCALE: 3:1

samtec

520 PARK EAST BLVD, NEW ALBANY, IN 47150
PHONE: 812-944-6733 FAX: 812-948-5047
e-Mail info@SAMTEC.com code 55322

DESCRIPTION:
.5MM EDGE RATE TERMINAL ASSEMBLY

DWG. NO.
ERM5-XXX-XX.X-X-DV-XX-X-XR

BY: DAVID W 4/30/2008 SHEET 3 OF 4

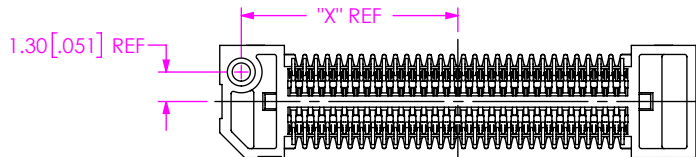
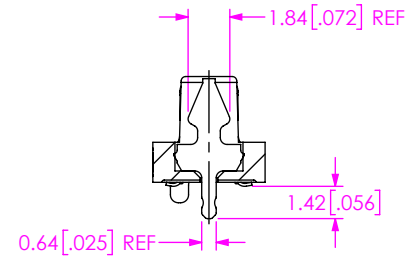
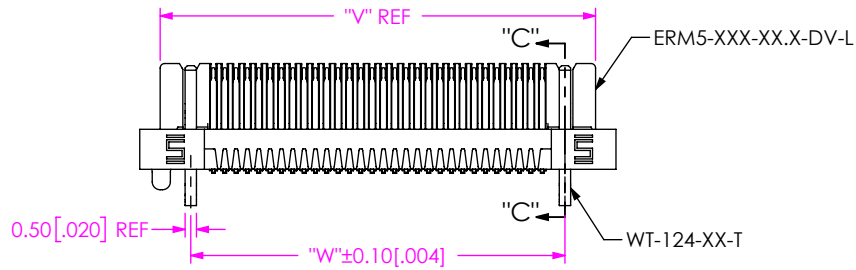
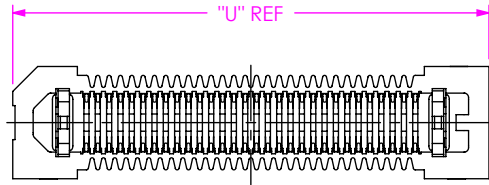

FIG 7
(ERM5-030-02.0-X-DV-L-XR SHOWN)
(SAME AS FIG 1 EXCEPT AS SHOWN)

TABLE 10		
LEAD STYLE	ERM5-XXX-XX.X-DV-XX	WT-124-XX-T
-02.0	ERM5-XXX-02.0-DV-L	WT-124-01-T
-05.0	ERM5-XXX-05.0-DV-L	WT-124-02-T

TABLE 11				
POSITION	"U"	"V"	"W"	"X"
-020	16.00 [0.630]	14.20 [0.559]	11.500 [0.4528]	7.05 [0.630]
-030	21.00 [0.827]	19.20 [0.756]	16.500 [0.6496]	9.55 [0.827]
-040	26.00 [1.024]	24.20 [0.953]	21.500 [0.8465]	12.05 [1.024]

PROPRIETARY NOTE
 THIS DOCUMENT CONTAINS CONFIDENTIAL AND PROPRIETARY INFORMATION AND ALL DESIGN, MANUFACTURING, REPRODUCTION, USE, PATENT RIGHTS AND SALES RIGHTS ARE EXPRESSLY RESERVED BY SAMTEC, INC. THIS DOCUMENT SHALL NOT BE DISCLOSED, IN WHOLE OR PART, TO ANY UNAUTHORIZED PERSON OR ENTITY NOR REPRODUCED, TRANSFERRED OR INCORPORATED IN ANY OTHER PROJECT IN ANY MANNER WITHOUT THE EXPRESS WRITTEN CONSENT OF SAMTEC, INC.



520 PARK EAST BLVD, NEW ALBANY, IN 47150
 PHONE: 812-944-6733 FAX: 812-948-5047
 e-Mail info@SAMTEC.com code 55322

DO NOT SCALE DRAWING

SHEET SCALE: 3:1

DESCRIPTION:
 .5MM EDGE RATE TERMINAL ASSEMBLY

DWG. NO.
 ERM5-XXX-XX.X-X-DV-XX-X-XR

BY: DAVID W 4/30/2008 SHEET 4 OF 4