



MMC3416PJ-B Prototyping Board

MMC3416PJ-B

GENERAL DESCRIPTION

The MMC3416PJ-B provides a convenient and easy way to evaluate and prototype with the MMC3416PJ three axes magnetic sensor. The magnetic sensor and passive components needed for operations are SMT mounted on the board. Communication, power and ground pins of the MMC3416PJ SMT device are brought out to standard 0.10 inch on center connections on the sides of the prototyping board. Wires can either be soldered directly to the prototyping board or DIP pins can be used with widely available breadboard kits.

For complete performance specifications of the MMC3416PJ refer to the MMC3416PJ datasheet.

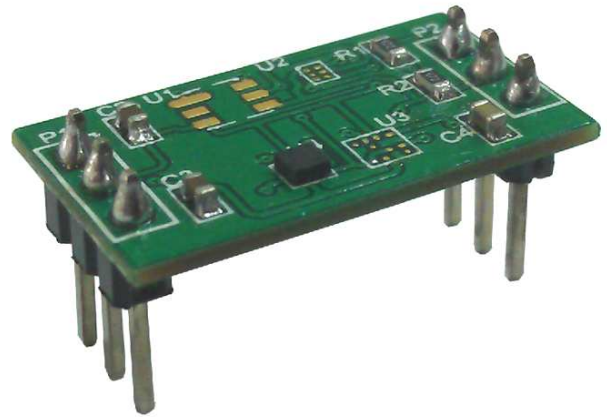

MMC3416PJ-B

PIN DESCRIPTION

Pin	Name	Description
P1-1	VDD	I2C Supply Voltage
P1-2	VDA	Power
P1-3	GND	Ground
P2-1	SDA	I2C SDA
P2-2	SCL	I2C SCL
P2-3	NC	No Connect

SCHEMATIC OF THE MMC3416PJ-B

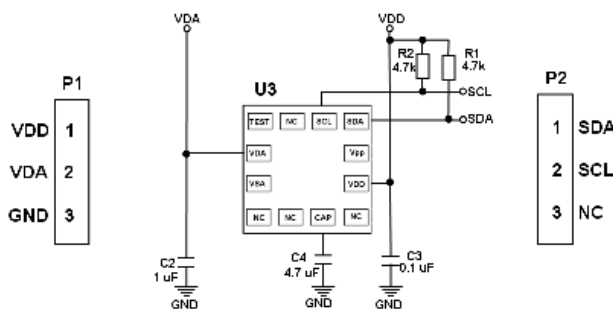

MMC3416PJ-B

PCB OUTLINE AND CONNECTION DIMENSIONS

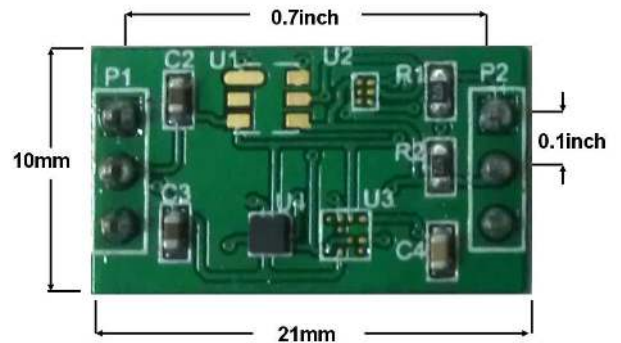

MMC3416PJ-B

Information furnished by MEMSIC is believed to be accurate and reliable. However, no responsibility is assumed by MEMSIC for its use, nor for any infringements of patents or other rights of third parties, which may result from its use. No license is granted by implication or otherwise under any patent or patent rights of MEMSIC.

©MEMSIC, Inc.
 One Technology Drive, Suite 325, Andover, MA, 01810, USA
 Tel: +1 978 738 0900 Fax: +1 978 738 0196
 www.memsic.com