

# TXS0108E-Q1 8-Bit Bi-directional, Level-Shifting, Voltage Translator for Open-Drain and Push-Pull Applications

## 1 Features

- AEC-Q100 Qualified for Automotive Applications
  - Device Temperature Grade 1:  $-40^{\circ}\text{C}$  to  $125^{\circ}\text{C}$
  - Device HBM ESD Classification Level 2
  - Device CDM ESD Classification Level C6
- No Direction-Control Signal Needed
- Maximum Data Rates
  - 110 Mbps (Push Pull)
  - 1.2 Mbps (Open Drain)
- 1.4 V to 3.6 V on A Port and 1.65 V to 5.5 V on B Port ( $V_{CCA} \leq V_{CCB}$ )
- No Power-Supply Sequencing Required – Either  $V_{CCA}$  or  $V_{CCB}$  Can Be Ramped First
- Latch-Up Performance Exceeds 100 mA Per JESD 78, Class II
- ESD Protection Exceeds JESD 22 (A Port)
  - 2000 V Human Body Model (A114-B)
  - 1000 V Charged-Device Model (C101)
- IEC 61000-4-2 ESD (B Port)
  - $\pm 8$  kV Contact Discharge
  - $\pm 6$  kV Air-Gap Discharge

## 2 Applications

- Automotive

## 3 Description

This device is a 8-bit non-inverting level translator which uses two separate configurable power-supply rails. The A port tracks the  $V_{CCA}$  pin supply voltage. The  $V_{CCA}$  pin accepts any supply voltage between 1.4 V and 3.6 V. The B port tracks the  $V_{CCB}$  pin supply voltage. The  $V_{CCB}$  pin accepts any supply voltage between 1.65 V and 5.5 V. Two input supply pins allows for low Voltage bidirectional translation between any of the 1.5 V, 1.8 V, 2.5 V, 3.3 V, and 5 V voltage nodes.

When the output-enable (OE) input is low, all outputs are placed in the high-impedance (Hi-Z) state.

To ensure the Hi-Z state during power-up or power-down periods, tie OE to GND through a pull-down resistor.

### Device Information

PART NUMBER	PACKAGE <sup>(1)</sup>	BODY SIZE (NOM)
TXS0108E-Q1	TSSOP (20)	6.50 mm × 6.40 mm

(1) For all available packages, see the orderable addendum at the end of the datasheet.

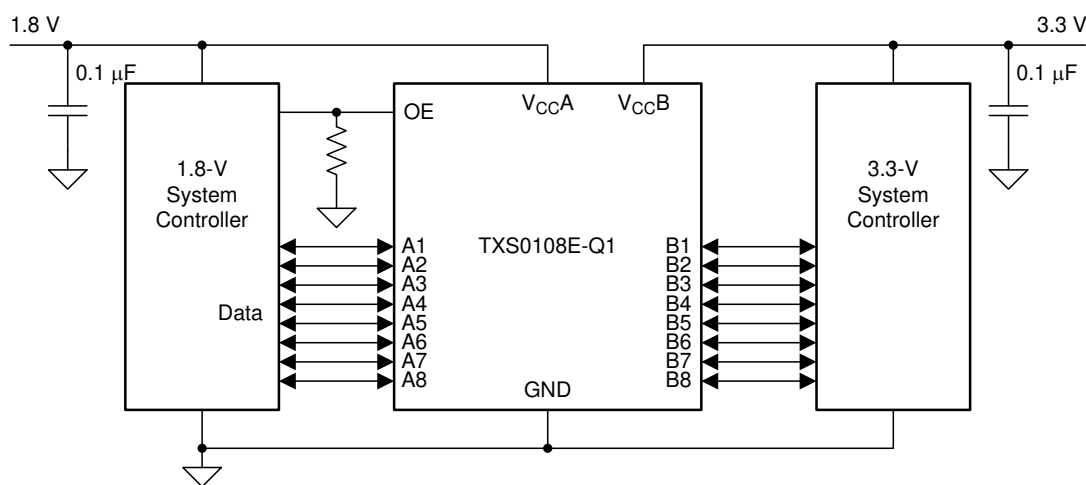

**Simplified Application**



## Table of Contents

<b>1 Features</b> .....	1	8.1 Load Circuits.....	13
<b>2 Applications</b> .....	1	8.2 Voltage Waveforms.....	14
<b>3 Description</b> .....	1	<b>9 Detailed Description</b> .....	15
<b>4 Revision History</b> .....	2	9.1 Overview.....	15
<b>5 Pin Configuration and Functions</b> .....	3	9.2 Functional Block Diagram.....	15
<b>6 Specifications</b> .....	4	9.3 Feature Description.....	16
6.1 Absolute Maximum Ratings.....	4	9.4 Device Functional Modes.....	17
6.2 ESD Ratings.....	4	<b>10 Application and Implementation</b> .....	18
6.3 Recommended Operating Conditions.....	5	10.1 Application Information.....	18
6.4 Thermal Information.....	5	10.2 Typical Application.....	18
6.5 Electrical Characteristics: $T_A = -40^{\circ}\text{C}$ to $125^{\circ}\text{C}$ .....	6	10.3 Power Supply Recommendations.....	19
6.6 Timing Requirements: $V_{CCA} = 1.5\text{ V} \pm 0.1\text{ V}$ .....	6	10.4 Layout.....	19
6.7 Timing Requirements: $V_{CCA} = 1.8\text{ V} \pm 0.15\text{ V}$ .....	7	<b>11 Device and Documentation Support</b> .....	21
6.8 Timing Requirements: $V_{CCA} = 2.5\text{ V} \pm 0.2\text{ V}$ .....	7	11.1 Receiving Notification of Documentation Updates..	21
6.9 Timing Requirements: $V_{CCA} = 3.3\text{ V} \pm 0.3\text{ V}$ .....	7	11.2 Support Resources.....	21
6.10 Switching Characteristics: $V_{CCA} = 1.5\text{ V} \pm 0.1\text{ V}$ .....	8	11.3 Trademarks.....	21
6.11 Switching Characteristics: $V_{CCA} = 1.8\text{ V} \pm 0.15\text{ V}$ .....	9	11.4 Electrostatic Discharge Caution.....	21
6.12 Switching Characteristics: $V_{CCA} = 2.5\text{ V} \pm 0.2\text{ V}$ .....	10	11.5 Glossary.....	21
6.13 Switching Characteristics: $V_{CCA} = 3.3\text{ V} \pm 0.3\text{ V}$ .....	11	<b>12 Mechanical, Packaging, and Orderable Information</b> .....	21
<b>7 Typical Characteristics</b> .....	12		
<b>8 Parameter Measurement Information</b> .....	13		

## 4 Revision History

NOTE: Page numbers for previous revisions may differ from page numbers in the current version.

Changes from Revision B (May 2020) to Revision C (July 2023)	Page
• Updated the numbering format for tables, figures, and cross-references throughout the document .....	1

---

Changes from Revision A (February 2016) to Revision B (May 2020)	Page
• Changed $V_{CCB\text{ MAX}}$ from 5.5 V to 6.5 V in the <i>Absolute Maximum Ratings</i> table .....	4

---

Changes from Revision * (June 2015) to Revision A (February 2016)	Page
• Made changes to Pin Functions .....	1

## 5 Pin Configuration and Functions

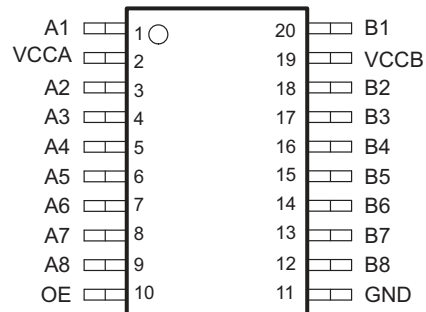

**Figure 5-1. PW PACKAGE 20-PIN TSSOP (TOP VIEW)**

### Pin Functions

PIN		I/O	DESCRIPTION
NAME	NO.		
A1	1	I/O	Input/output 1. Referenced to $V_{CCA}$
A2	3	I/O	Input/output 2. Referenced to $V_{CCA}$
A3	4	I/O	Input/output 3. Referenced to $V_{CCA}$
A4	5	I/O	Input/output 4. Referenced to $V_{CCA}$
A5	6	I/O	Input/output 5. Referenced to $V_{CCA}$
A6	7	I/O	Input/output 6. Referenced to $V_{CCA}$
A7	8	I/O	Input/output 7. Referenced to $V_{CCA}$
A8	9	I/O	Input/output 8. Referenced to $V_{CCA}$
B1	20	I/O	Input/output 1. Referenced to $V_{CCB}$
B2	18	I/O	Input/output 2. Referenced to $V_{CCB}$
B3	17	I/O	Input/output 3. Referenced to $V_{CCB}$
B4	16	I/O	Input/output 4. Referenced to $V_{CCB}$
B5	15	I/O	Input/output 5. Referenced to $V_{CCB}$
B6	14	I/O	Input/output 6. Referenced to $V_{CCB}$
B7	13	I/O	Input/output 7. Referenced to $V_{CCB}$
B8	12	I/O	Input/output 8. Referenced to $V_{CCB}$
GND	11	–	Ground
OE	10	I	3-state output-mode enable. Pull OE low to place all outputs in 3-state mode. Referenced to $V_{CCA}$ .
VCCA	2	–	A-port supply voltage. $1.4\text{ V} \leq V_{CCA} \leq 3.6\text{ V}$ , $V_{CCA} \leq V_{CCB}$ .
VCCB	19	–	B-port supply voltage. $1.65\text{ V} \leq V_{CCB} \leq 5.5\text{ V}$ .

## 6 Specifications

### 6.1 Absolute Maximum Ratings

over operating free-air temperature range (unless otherwise noted)<sup>(1)</sup>

		MIN	MAX	UNIT
Supply voltage, $V_{CCA}$		-0.5	4.6	V
Supply voltage, $V_{CCB}$		-0.5	6.5	V
Input voltage, $V_I$ <sup>(2)</sup>	A port	-0.5	4.6	V
	B port	-0.5	6.5	
Voltage applied to any output in the high-impedance or power-off state, $V_O$ <sup>(2)</sup>	A port	-0.5	4.6	V
	B port	-0.5	6.5	
Voltage applied to any output in the high or low state, $V_O$ <sup>(2) (3)</sup>	A port	-0.5	$V_{CCA} + 0.5$	V
	B port	-0.5	$V_{CCB} + 0.5$	V
Input clamp current, $I_{IK}$	$V_I < 0$		-50	mA
Output clamp current, $I_{OK}$	$V_O < 0$		-50	mA
Continuous output current, $I_O$		-50	50	mA
Continuous current through $V_{CCA}$ , $V_{CCB}$ , or GND		-100	100	mA
Junction temperature, $T_J$			150	°C
Storage temperature, $T_{stg}$		-65	150	°C

- (1) Stresses beyond those listed under *Absolute Maximum Ratings* may cause permanent damage to the device. These are stress ratings only, and functional operation of the device at these or any other conditions beyond those indicated under *Recommended Operating Conditions* is not implied. Exposure to absolute-maximum-rated conditions for extended periods may affect device reliability.
- (2) The input and output negative Voltage ratings may be exceeded if the input and output current ratings are observed.
- (3) The value of  $V_{CCA}$  and  $V_{CCB}$  are provided in the recommended operating conditions table.

### 6.2 ESD Ratings

			VALUE	UNIT
$V_{(ESD)}$	Electrostatic discharge	Human-body model (HBM), per AEC Q100-002 <sup>(1)</sup>	±2000	V
		Charged-device model (CDM), per AEC Q100-011	±1000	

- (1) AEC Q100-002 indicates that HBM stressing shall be in accordance with the ANSI/ESDA/JEDEC JS-001 specification.

### 6.3 Recommended Operating Conditions

over operating free-air temperature range (unless otherwise noted)<sup>(1)</sup> <sup>(2)</sup>

				MIN	MAX	UNIT	
V <sub>CCA</sub>	Supply voltage <sup>(3)</sup>			1.4	3.6	V	
V <sub>CCB</sub>	Supply voltage <sup>(3)</sup>			1.65	5.5	V	
V <sub>IH</sub>	High-level input voltage	A-Port I/Os	V <sub>CCA</sub> (V) = 1.4 to 1.95	V <sub>CCB</sub> (V) = 1.65 to 5.5	V <sub>CCI</sub> – 0.2	V <sub>CCI</sub>	V
			V <sub>CCA</sub> (V) = 1.95 to 3.6	V <sub>CCB</sub> (V) = 1.65 to 5.5	V <sub>CCI</sub> – 0.4	V <sub>CCI</sub>	
		B-Port I/Os	V <sub>CCA</sub> (V) = 1.4 to 3.6	V <sub>CCB</sub> (V) = 1.65 to 5.5	V <sub>CCI</sub> – 0.4	V <sub>CCI</sub>	V
		OE	V <sub>CCA</sub> (V) = 1.4 to 3.6	V <sub>CCB</sub> (V) = 1.65 to 5.5	V <sub>CCA</sub> × 0.65	5.5	V
V <sub>IL</sub>	Low-level input voltage	A-Port I/Os	V <sub>CCA</sub> (V) = 1.4 to 1.95	V <sub>CCB</sub> (V) = 1.65 to 5.5	0	0.15	V
			V <sub>CCA</sub> (V) = 1.95 to 3.6	V <sub>CCB</sub> (V) = 1.65 to 5.5	0	0.15	
		B-Port I/Os	V <sub>CCA</sub> (V) = 1.4 to 3.6	V <sub>CCB</sub> (V) = 1.65 to 5.5	0	0.15	V
		OE	V <sub>CCA</sub> (V) = 1.4 to 3.6	V <sub>CCB</sub> (V) = 1.65 to 5.5	0	V <sub>CCA</sub> × 0.35	V
Δt/Δv	Input transition rise or fall rate	A-Port I/Os Push-pull	V <sub>CCA</sub> (V) = 1.4 to 3.6	V <sub>CCB</sub> (V) = 1.65 to 5.5	10		ns/V
		B-Port I/Os Push-pull	V <sub>CCA</sub> (V) = 1.4 to 3.6	V <sub>CCB</sub> (V) = 1.65 to 5.5	10		ns/V
		Control input	V <sub>CCA</sub> (V) = 1.4 to 3.6	V <sub>CCB</sub> (V) = 1.65 to 5.5	10		ns/V
T <sub>A</sub>	Operating free-air temperature			–40	125	°C	

- (1) V<sub>CCI</sub> is the V<sub>CC</sub> associated with the data input port.  
(2) V<sub>CCO</sub> is the V<sub>CC</sub> associated with the output port.  
(3) V<sub>CCA</sub> must be less than or equal to V<sub>CCB</sub>, and V<sub>CCA</sub> must not exceed 3.6 V.

### 6.4 Thermal Information

THERMAL METRIC <sup>(1)</sup>		TXS0108E-Q1	UNIT
		PW (TSSOP)	
		20 PINS	
R <sub>θJA</sub>	Junction-to-ambient thermal resistance	101.5	°C/W
R <sub>θJC(top)</sub>	Junction-to-case (top) thermal resistance	35.9	
R <sub>θJB</sub>	Junction-to-board thermal resistance	52.4	
Ψ <sub>JT</sub>	Junction-to-top characterization parameter	2.3	
Ψ <sub>JB</sub>	Junction-to-board characterization parameter	51.9	
R <sub>θJC(bot)</sub>	Junction-to-case (bottom) thermal resistance	—	

- (1) For more information about traditional and new thermal metrics, see the *Semiconductor and IC Package Thermal Metrics* application report, [SPRA953](#).

### 6.5 Electrical Characteristics: $T_A = -40^{\circ}\text{C}$ to $125^{\circ}\text{C}$

over recommended operating free-air temperature range (unless otherwise noted)<sup>(1) (2) (3)</sup>

PARAMETER	TEST CONDITIONS	$V_{CCA}$ (V)	$V_{CCB}$ (V)	$T_A = 25^{\circ}\text{C}$			$T_A = -40^{\circ}\text{C}$ to $125^{\circ}\text{C}$		UNIT
				MIN	TYP	MAX	MIN	MAX	
$V_{OHA}$ Port A output high voltage	$I_{OH} = -20\ \mu\text{A}$ , $V_{IB} \geq V_{CCB} - 0.4\ \text{V}$	1.4 to 3.6	1.65 to 5.5				$V_{CCA} \times 0.67$		V
$V_{OLA}$ Port A output low voltage	$I_{OL} = 180\ \mu\text{A}$ , $V_{IB} \leq 0.15\ \text{V}$	1.4	1.65 to 5.5				0.4		V
	$I_{OL} = 220\ \mu\text{A}$ , $V_{IB} \leq 0.15\ \text{V}$	1.65	1.65 to 5.5				0.4		
	$I_{OL} = 300\ \mu\text{A}$ , $V_{IB} \leq 0.15\ \text{V}$	2.3	1.65 to 5.5				0.4		
	$I_{OL} = 400\ \mu\text{A}$ , $V_{IB} \leq 0.15\ \text{V}$	3	1.65 to 5.5				0.55		
$V_{OHB}$ Port B output high voltage	$I_{OH} = -20\ \mu\text{A}$ , $V_{IA} \geq V_{CCA} - 0.2\ \text{V}$	1.4 to 3.6	1.65 to 5.5				$V_{CCB} \times 0.67$		V
$V_{OLB}$ Port B output low voltage	$I_{OL} = 220\ \mu\text{A}$ , $V_{IA} \leq 0.15\ \text{V}$	1.4 to 3.6	1.65				0.4		V
	$I_{OL} = 300\ \mu\text{A}$ , $V_{IA} \leq 0.15\ \text{V}$	1.4 to 3.6	2.3				0.4		
	$I_{OL} = 400\ \mu\text{A}$ , $V_{IA} \leq 0.15\ \text{V}$	1.4 to 3.6	3				0.55		
	$I_{OL} = 620\ \mu\text{A}$ , $V_{IA} \leq 0.15\ \text{V}$	1.4 to 3.6	4.5				0.55		
$I_I$ Input leakage current	OE: $V_I = V_{CCI}$ or GND	1.4	1.65 to 5.5	-1		1		2	$\mu\text{A}$
$I_{OZ}$ High-impedance state output current	A or B port	1.4	1.65 to 5.5	-1		1	-2	2	$\mu\text{A}$
$I_{CCA}$ $V_{CCA}$ supply current	$V_I = V_O = \text{Open}$ , $I_O = 0$	1.4 to 3.6	2.3 to 5.5				2		$\mu\text{A}$
		3.6	0				2		
		0	5.5				-1		
$I_{CCB}$ $V_{CCB}$ supply current	$V_I = V_O = \text{Open}$ , $I_O = 0$	1.4 to 3.6	2.3 to 5.5				6		$\mu\text{A}$
		3.6	0				-1		
		0	5.5				1.5		
$I_{CCA} + I_{CCB}$ Combined supply current	$V_I = V_{CCI}$ or GND, $I_O = 0$	1.4 to 3.6	2.3 to 5.5				8		$\mu\text{A}$
$I_{CCZA}$ High-impedance state $V_{CCA}$ supply current	$V_I = V_O = \text{Open}$ , $I_O = 0$ , OE = GND	1.4 to 3.6	1.65 to 5.5				2		$\mu\text{A}$
$I_{CCZB}$ High-impedance state $V_{CCB}$ supply current	$V_I = V_O = \text{Open}$ , $I_O = 0$ , OE = GND	1.4 to 3.6	1.65 to 5.5				6		$\mu\text{A}$
$C_i$ Input capacitance	OE	3.3	3.3		4.5		6.75		pF
$C_{io}$ Input-to-output internal capacitance	A port	3.3	3.3		6		7.6		pF
	B port	3.3	3.3		5.5		6.9		

- (1)  $V_{CCO}$  is the  $V_{CC}$  associated with the output port.
- (2)  $V_{CCI}$  is the  $V_{CC}$  associated with the input port.
- (3)  $V_{CCA}$  must be less than or equal to  $V_{CCB}$ , and  $V_{CCA}$  must not exceed 3.6 V.

### 6.6 Timing Requirements: $V_{CCA} = 1.5\ \text{V} \pm 0.1\ \text{V}$

over recommended operating free-air temperature range,  $V_{CCA} = 1.5\ \text{V} \pm 0.1\ \text{V}$  (unless otherwise noted)

		$V_{CC B} = 1.8\ \text{V} \pm 0.15\ \text{V}$		$V_{CC B} = 2.5\ \text{V} \pm 0.2\ \text{V}$		$V_{CC B} = 3.3\ \text{V} \pm 0.3\ \text{V}$		$V_{CC B} = 5\ \text{V} \pm 0.5\ \text{V}$		UNIT
		MIN	MAX	MIN	MAX	MIN	MAX	MIN	MAX	
Data rate	Push-pull	40		60		60		60		Mbps
	Open-drain	0.8		0.8		1		1		
$t_w$ Pulse duration	Data inputs	Push-pull	25	16.7	16.7	16.7	16.7			ns
		Open-drain	1250	1250	1000	1000				

### 6.7 Timing Requirements: $V_{CCA} = 1.8\text{ V} \pm 0.15\text{ V}$

over recommended operating free-air temperature range,  $V_{CCA} = 1.8\text{ V} \pm 0.15\text{ V}$  (unless otherwise noted)

			$V_{CC\ B} = 1.8\text{ V} \pm 0.15\text{ V}$		$V_{CC\ B} = 2.5\text{ V} \pm 0.2\text{ V}$		$V_{CC\ B} = 3.3\text{ V} \pm 0.3\text{ V}$		$V_{CC\ B} = 5\text{ V} \pm 0.5\text{ V}$		UNIT
			MIN	MAX	MIN	MAX	MIN	MAX	MIN	MAX	
Data rate	Push-pull		45		65		70		70		Mbps
	Open-drain		0.8		0.8		0.8		1		
$t_w$ Pulse duration	Data inputs	Push-pull	22.2		15.3		15.3		15.3		ns
		Open-drain	1250		1250		1250		1000		

### 6.8 Timing Requirements: $V_{CCA} = 2.5\text{ V} \pm 0.2\text{ V}$

over recommended operating free-air temperature range,  $V_{CCA} = 2.5\text{ V} \pm 0.2\text{ V}$  (unless otherwise noted)

			$V_{CC\ B} = 2.5\text{ V} \pm 0.2\text{ V}$		$V_{CC\ B} = 3.3\text{ V} \pm 0.3\text{ V}$		$V_{CC} = 5\text{ V} \pm 0.5\text{ V}$		UNIT
			MIN	MAX	MIN	MAX	MIN	MAX	
Data rate	Push-pull		80		95		100		Mbps
	Open-drain		0.8		0.8		1		
$t_w$ Pulse duration	Data inputs	Push-pull	12.5		10.5		10		ns
		Open-drain	1250		1250		1000		

### 6.9 Timing Requirements: $V_{CCA} = 3.3\text{ V} \pm 0.3\text{ V}$

over recommended operating free-air temperature range,  $V_{CCA} = 3.3\text{ V} \pm 0.3\text{ V}$  (unless otherwise noted)

			$V_{CC\ B} = 3.3\text{ V} \pm 0.3\text{ V}$		$V_{CC} = 5\text{ V} \pm 0.5\text{ V}$		UNIT
			MIN	MAX	MIN	MAX	
Data rate	Push-pull		100		110		Mbps
	Open-drain		0.8		1.2		
$t_w$ Pulse duration	Data inputs	Push-pull	10		9.1		ns
		Open-drain	1250		833		

### 6.10 Switching Characteristics: $V_{CCA} = 1.5\text{ V} \pm 0.1\text{ V}$

over recommended operating free-air temperature range,  $V_{CCA} = 1.5\text{ V} \pm 0.1\text{ V}$  (unless otherwise noted)

PARAMETER	TEST CONDITIONS		$V_{CCB} = 1.8\text{ V} \pm 0.15\text{ V}$		$V_{CCB} = 2.5\text{ V} \pm 0.2\text{ V}$		$V_{CCB} = 3.3\text{ V} \pm 0.3\text{ V}$		$V_{CCB} = 5\text{ V} \pm 0.5\text{ V}$		UNIT
			MIN	MAX	MIN	MAX	MIN	MAX	MIN	MAX	
$t_{PHL}$ Propagation delay time high-to-low output	A-to-B	Push-pull driving	11		9.2		8.6		8.6		ns
		Open-drain driving	2.5	14.4	2	12.8	2	12.2	1.9	12	
$t_{PLH}$ Propagation delay time low-to-high output	A-to-B	Push-pull driving	12		10		9.8		9.7		ns
		Open-drain driving	0.9	720	0.9	554	1	473	1.5	384	
$t_{PHL}$ Propagation delay time high-to-low output	B-to-A	Push-pull driving	12.7		11.1		11		12		ns
		Open-drain driving	3.4	13.2	2.6	9.6	2.3	8.5	2	7.5	
$t_{PLH}$ Propagation delay time low-to-high output	B-to-A	Push-pull driving	9.5		6.2		5.1		4.2		ns
		Open-drain driving	745		603		519		407		
$t_{en}$ Enable time	OE-to-A or B	Push-pull driving	480		480		480		480		ns
$t_{dis}$ Disable time	OE-to-A or B	Push-pull driving	400		400		400		400		ns
$t_{rA}$ Input rise time	A-port rise time	Push-pull driving	3	13.1	2.4	9.8	2	9	2	8.9	ns
		Open-drain driving	220	982	180	716	140	592	100	481	
$t_{rB}$ Input rise time	B-port rise time	Push-pull driving	2.6	11.4	1.6	7.4	1	6	0.7	5	ns
		Open-drain driving	220	1020	150	756	100	653	40	370	
$t_{fA}$ Input fall time	A-port fall time	Push-pull driving	2.3	9.9	1.7	7.7	1.6	6.8	1.7	6	ns
		Open-drain driving	2.4	10	1.8	8.2	1.7	9	1.5	9.15	
$t_{fB}$ Input fall time	B-port fall time	Push-pull driving	2	8.7	1.3	5.5	1	3.8	1	3.1	ns
		Open-drain driving	2	11.5	1.3	8.6	1	9.6	1	7.7	
$t_{SK(O)}$ Skew (time), output	Channel-to-channel skew	Push-pull driving	1		1		1		1		ns



## 6.11 Switching Characteristics: $V_{CCA} = 1.8 \text{ V} \pm 0.15 \text{ V}$

over recommended operating free-air temperature range,  $V_{CCA} = 1.8 \text{ V} \pm 0.15 \text{ V}$  (unless otherwise noted)

PARAMETER	TEST CONDITIONS	$V_{CCB} = 1.8 \text{ V} \pm 0.15 \text{ V}$		$V_{CCB} = 2.5 \text{ V} \pm 0.2 \text{ V}$		$V_{CCB} = 3.3 \text{ V} \pm 0.3 \text{ V}$		$V_{CCB} = 5 \text{ V} \pm 0.5 \text{ V}$		UNIT		
		MIN	MAX	MIN	MAX	MIN	MAX	MIN	MAX			
$t_{PHL}$	Propagation delay time high-to-low output	A-to-B	Push-pull driving	8.2		6.4		5.7		ns		
				Open-drain driving	2.1	11.4	1.7	9.9	1.6		9.3	1.5
$t_{PLH}$	Propagation delay time low-to-high output	A-to-B	Push-pull driving		9		5.6		6.5		ns	
				Open-drain driving	0.15	729	0.2	584	0.3	466		0.3
$t_{PHL}$	Propagation delay time high-to-low output	B-to-A	Push-pull driving		9.8		8		7.4		ns	
				Open-drain driving	3.19	12.1	2	8.5	1.9	7.3		1.8
$t_{PLH}$	Propagation delay time low-to-high output	B-to-A	Push-pull driving		10.2		7		5.8		ns	
				Open-drain driving	733		578		459			323
$t_{en}$	Enable time	OE-to-A or B	Push-pull driving		100		100		100		ns	
$t_{dis}$	Disable time	OE-to-A or B	Push-pull driving	410		410		410		ns		
$t_{rA}$	Input rise time	A-port rise time	Push-pull driving	2.7	11.9	2	8.6	1.9	7.8	1.8	7.4	ns
				Open-drain driving	250	996	200	691	150	508	110	
$t_{rB}$	Input rise time	B-port rise time	Push-pull driving		2.5	10.5	1.7	7.4	1.1	5.3	60	4.7
				Open-drain driving	250	1001	170	677	120	546	32	323
$t_{fA}$	Input fall time	A-port fall time	Push-pull driving		2.1	8.8	1.6	7.1	1.4	6.8	1.4	6.06
				Open-drain driving	2.2	9	1.7	7.2	1.4	6.8	1.2	6.1
$t_{fB}$	Input fall time	B-port fall time	Push-pull driving		2	8.3	1.3	5.4	0.9	3.9	0.7	3
				Open-drain driving	2	10.5	1	10.7	1	9.6	0.6	7.8
$t_{SK(O)}$	Skew (time), output	Channel-to-channel skew	Push-pull driving		1		1		1		ns	

### 6.12 Switching Characteristics: $V_{CCA} = 2.5\text{ V} \pm 0.2\text{ V}$

over recommended operating free-air temperature range,  $V_{CCA} = 2.5\text{ V} \pm 0.2\text{ V}$  (unless otherwise noted)

PARAMETER		TEST CONDITIONS		$V_{CCB} = 2.5\text{ V} \pm 0.2\text{ V}$		$V_{CCB} = 3.3\text{ V} \pm 0.3\text{ V}$		$V_{CCB} = 5\text{ V} \pm 0.5\text{ V}$		UNIT
				MIN	MAX	MIN	MAX	MIN	MAX	
$t_{PHL}$	Propagation delay time high-to-low output	A-to-B	Push-pull driving		5		4		3.7	ns
			Open-drain driving		6.2		6.3		5.8	
$t_{PLH}$	Propagation delay time low-to-high output	A-to-B	Push-pull driving		5.2		4.3		3.9	
			Open-drain driving		5		17.5		15.5	
$t_{PHL}$	Propagation delay time high-to-low output	B-to-A	Push-pull driving		5.4		4.7		4.2	ns
			Open-drain driving		7.3		6		4.9	
$t_{PLH}$	Propagation delay time low-to-high output	B-to-A	Push-pull driving		5.9		4.4		3.5	
			Open-drain driving		5		5		5	
$t_{en}$	Enable time	OE-to-A or B	Push-pull driving		100		100		100	ns
$t_{dis}$	Disable time	OE-to-A or B			400		400		400	ns
$t_{rA}$	Input rise time	A-port rise time	Push-pull driving	1.89	7.3	1.6	6.4	1.5	5.8	ns
			Open-drain driving	110.00	692	157	529	116	377	
$t_{rB}$	Input rise time	B-port rise time	Push-pull driving	1.70	6.5	1.3	5.1	0.9	4.32	ns
			Open-drain driving	107.00	693	140	483	77	304	
$t_{fA}$	Input fall time	A-port fall time	Push-pull driving	1.50	5.7	1.2	4.7	1.3	3.8	ns
			Open-drain driving	1.50	5.6	1.2	4.7	1.1	4.2	
$t_{fB}$	Input fall time	B-port fall time	Push-pull driving	1.40	5.4	0.9	4.1	0.7	3	
			Open-drain driving	0.40	14.2	0.5	19.4	0.4	3	
$t_{SK(O)}$	Skew (time), output	Channel-to-channel skew	Push-pull driving		1		1		1	ns

### 6.13 Switching Characteristics: $V_{CCA} = 3.3\text{ V} \pm 0.3\text{ V}$

over recommended operating free-air temperature range,  $V_{CCA} = 3.3\text{ V} \pm 0.3\text{ V}$  (unless otherwise noted)

PARAMETER	TEST CONDITION (DRIVING)		$V_{CCB} = 3.3\text{ V} \pm 0.3\text{ V}$		$V_{CCB} = 5\text{ V} \pm 0.5\text{ V}$		UNIT	
			MIN	MAX	MIN	MAX		
$t_{PHL}$	Propagation delay time high-to-low output	A-to-B	Push-pull driving	3.8	3.28		ns	
			Open-drain driving	5.3	4.8			
$t_{PLH}$	Propagation delay time low-to-high output	A-to-B	Push-pull driving	3.9	3.5			
			Open-drain driving	5	12.5			
$t_{PHL}$	Propagation delay time high-to-low output	B-to-A	Push-pull driving	4.2	3.8		ns	
			Open-drain driving	5.5	4.5			
$t_{PLH}$	Propagation delay time low-to-high output	B-to-A	Push-pull driving	4.32	4.3			
			Open-drain driving	5	5			
$t_{en}$	Enable time	OE-to-A or B	Push-pull driving	100	100		ns	
$t_{dis}$	Disable time	OE-to-A or B	Push-pull driving	400	400		ns	
$t_{rA}$	Input rise time	A-port rise time	Push-pull driving	1.5	5.7	1.4	5	ns
			Open-drain driving	129	446	99.6	337	
$t_{rB}$	Input rise time	B-port rise time	Push-pull driving	1.35	5	1	4.24	ns
			Open-drain driving	129	427	77	290	
$t_{fA}$	Input fall time	A-port fall time	Push-pull driving	1.4	4.5	1.3	3.5	ns
			Open-drain driving	1.4	4.4	1.2	3.7	
$t_{fB}$	Input fall time	B-port fall time	Push-pull driving	1.3	4.2	1.1	3.1	
			Open-drain driving	1.3	4.2	1.1	3.1	
$t_{SK(O)}$	Skew (time), output	Channel-to-channel skew	Push-pull driving	1	1		ns	

## 7 Typical Characteristics

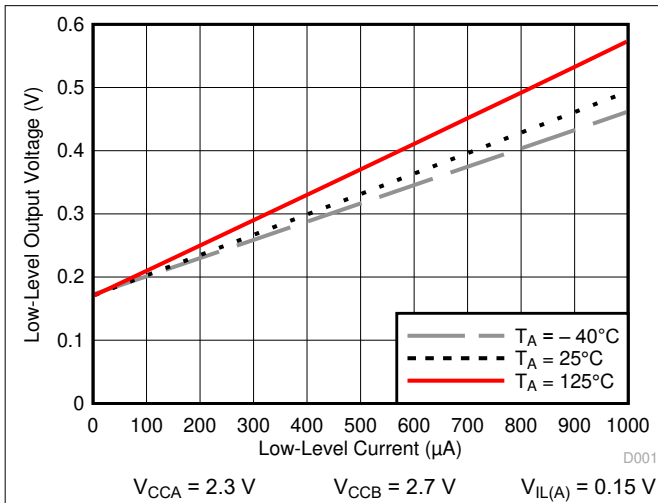

**Figure 7-1. Low-Level Output Voltage ( $V_{OL(Bx)}$ ) vs Low-Level Current ( $I_{OL(Bx)}$ )**

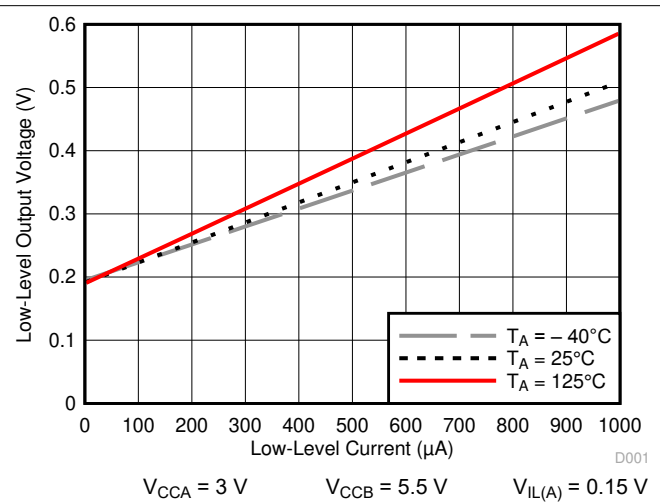

**Figure 7-2. Low-Level Output Voltage ( $V_{OL(Bx)}$ ) vs Low-Level Current ( $I_{OL(Bx)}$ )**

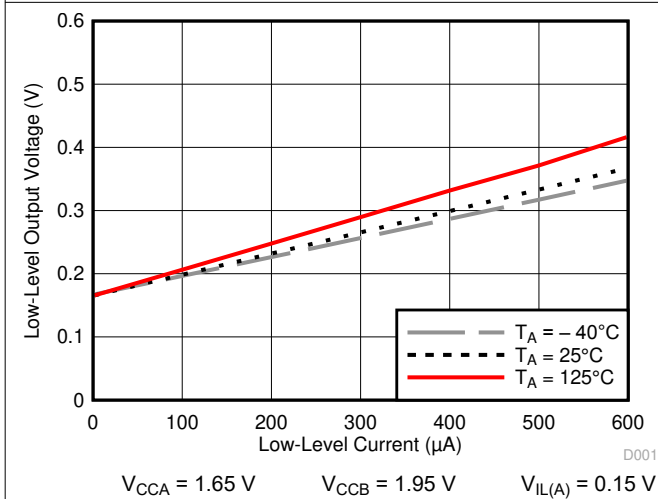

**Figure 7-3. Low-Level Output Voltage ( $V_{OL(Bx)}$ ) vs Low-Level Current ( $I_{OL(Bx)}$ )**

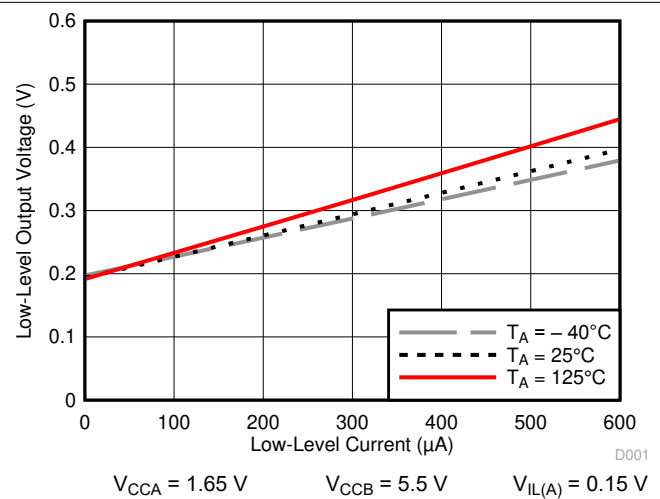
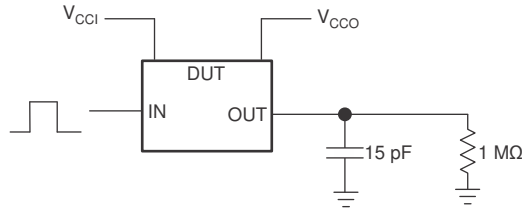

**Figure 7-4. Low-Level Output Voltage ( $V_{OL(Bx)}$ ) vs Low-Level Current ( $I_{OL(Bx)}$ )**

## 8 Parameter Measurement Information

### 8.1 Load Circuits

Figure 8-1 shows the push-pull driver circuit used for measuring data rate, pulse duration, propagation delay, output rise-time and fall-time. Figure 8-2 shows the open-drain driver circuit used for measuring data rate, pulse duration, propagation delay, output rise-time and fall-time.



- A.  $V_{CCI}$  is the  $V_{CC}$  associated with the input port.
- B.  $V_{CCO}$  is the  $V_{CC}$  associated with the output port.

**Figure 8-1. Data Rate, Pulse Duration, Propagation Delay, Output Rise-Time And Fall-Time Measurement Using a Push-Pull Driver**

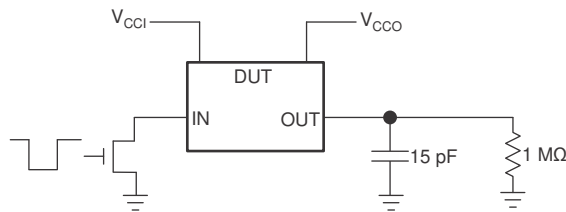

- A.  $V_{CCI}$  is the  $V_{CC}$  associated with the input port.
- B.  $V_{CCO}$  is the  $V_{CC}$  associated with the output port.

**Figure 8-2. Data Rate (10 pF), Pulse Duration (10 pF), Propagation Delay, Output Rise-Time And Fall-Time Measurement Using an Open-Drain Driver**

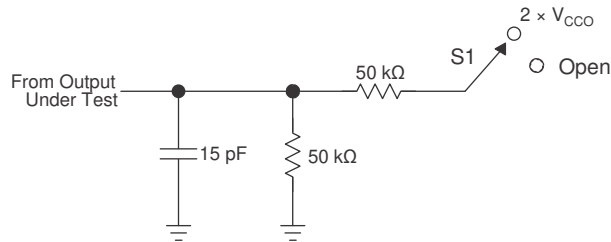

TEST	S1
$t_{PZL}$ , $t_{PLZ}$ ( $t_{dis}$ )	$2 \times V_{CCO}$
$t_{PHZ}$ , $t_{PZH}$ ( $t_{en}$ )	Open

- A.  $t_{PLZ}$  and  $t_{PHZ}$  are the same as  $t_{dis}$ .
- B.  $t_{PZL}$  and  $t_{PZH}$  are the same as  $t_{en}$ .

**Figure 8-3. Load Circuit for Enable-Time and Disable-Time Measurement**

## 8.2 Voltage Waveforms

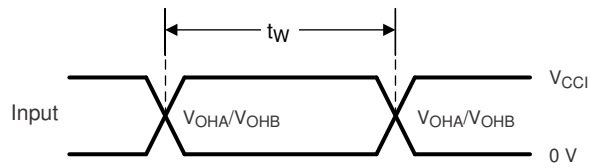

Figure 8-4. Pulse Duration (Push-Pull)

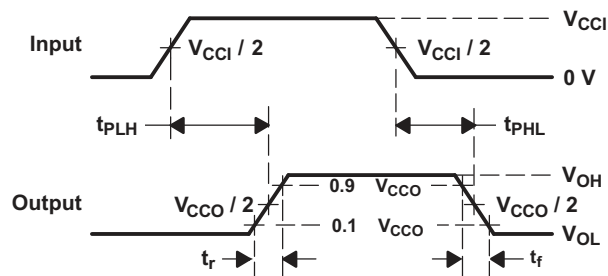
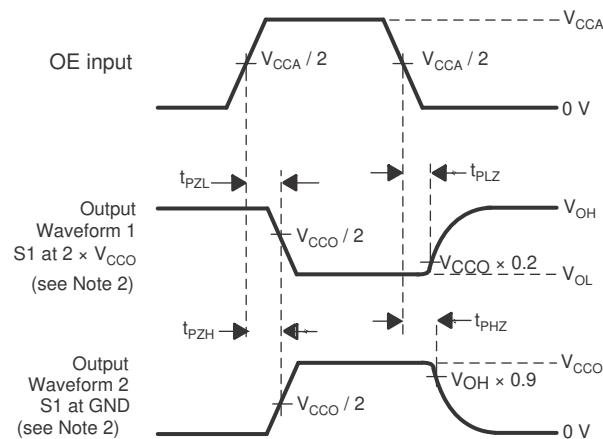

Figure 8-5. Propagation Delay Times



- $C_L$  includes probe and jig capacitance.
- Waveform 1 in Figure 8-6 is for an output with internal such that the output is high, except when OE is high (see Figure 8-3). Waveform 2 in Figure 8-6 is for an output with conditions such that the output is low, except when OE is high.
- All input pulses are supplied by generators having the following characteristics:  $PRR \leq 10 \text{ MHz}$ ,  $Z_O = 50 \Omega$ ,  $dv/dt \geq 1 \text{ V/ns}$ .
- The outputs are measured one at a time, with one transition per measurement.
- $t_{PLZ}$  and  $t_{PHZ}$  are the same as  $t_{dis}$ .
- $t_{PZL}$  and  $t_{PZH}$  are the same as  $t_{en}$ .
- $t_{PLH}$  and  $t_{PHL}$  are the same as  $t_{pd}$ .
- $V_{CCI}$  is the  $V_{CC}$  associated with the input port.
- $V_{CCO}$  is the  $V_{CC}$  associated with the output port.

Figure 8-6. Enable and Disable Times

## 9 Detailed Description

### 9.1 Overview

The TXS0108E-Q1 device is a directionless voltage-level translator specifically designed for translating logic voltage levels. The A-port accepts I/O voltages ranging from 1.4 V to 3.6 V. The B-port accepts I/O voltages from 1.65 V to 5.5 V. The device uses pass gate architecture with edge rate accelerators (one shots) to improve the overall data rate. The pull-up resistors, commonly used in open-drain applications, have been conveniently integrated so that an external resistor is not needed. While this device is designed for open-drain applications, the device can also translate push-pull CMOS logic outputs.

### 9.2 Functional Block Diagram

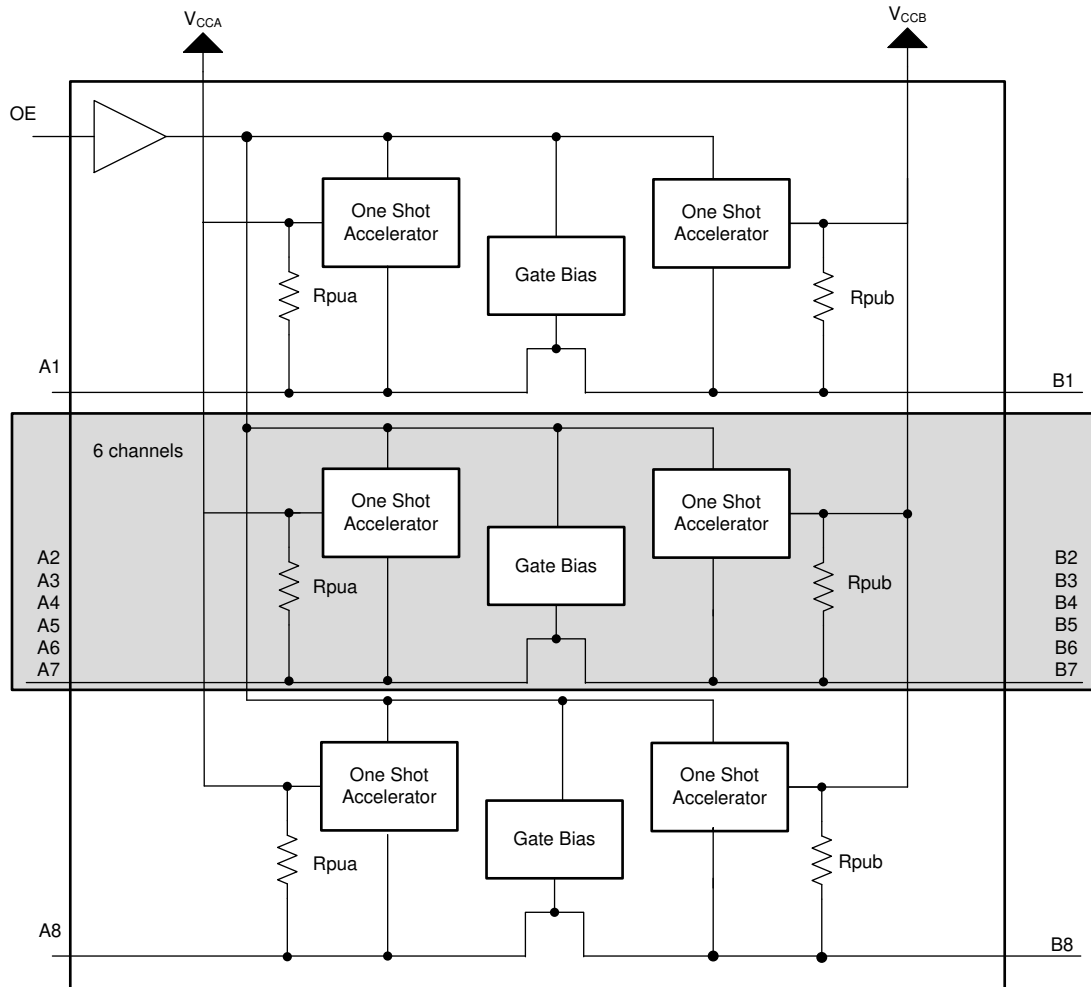

**Figure 9-1. Functional Block Diagram**

Each A-port I/O has a pull-up resistor ( $R_{PUA}$ ) to  $V_{CCA}$  and each B-port I/O has a pull-up resistor ( $R_{PUB}$ ) to  $V_{CCB}$ .  $R_{PUA}$  and  $R_{PUB}$  have a value of 40 k $\Omega$  when the output is driving low.  $R_{PUA}$  and  $R_{PUB}$  have a value of 4 k $\Omega$  when the output is driving high.  $R_{PUA}$  and  $R_{PUB}$  are disabled when OE = Low.

## 9.3 Feature Description

### 9.3.1 Architecture

Figure 9-2 describes semi-buffered architecture design this application requires for both push-pull and open-drain mode. This application uses edge-rate accelerator circuitry (for both the high-to-low and low-to-high edges), a high-on-resistance N-channel pass-gate transistor (on the order of 300  $\Omega$  to 500  $\Omega$ ) and pull-up resistors (to provide DC-bias and drive capabilities) to meet these requirements. This design needs no direction-control signal (to control the direction of data flow from A to B or from B to A). The resulting implementation supports both low-speed open-drain operation as well as high-speed push-pull operation.

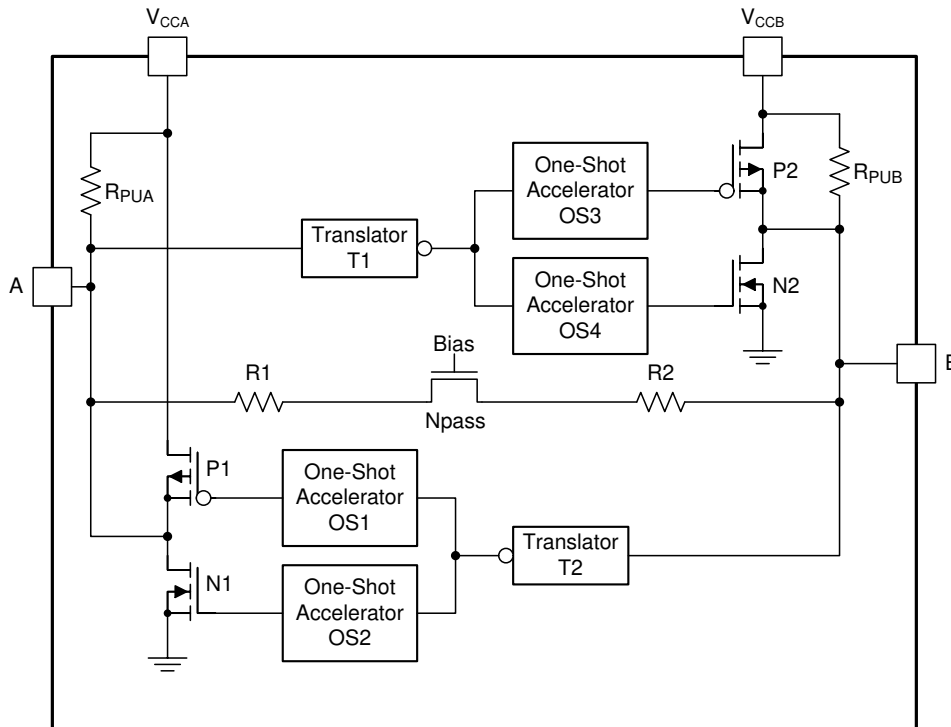

**Figure 9-2. Architecture of a TXS0108E-Q1 Cell**

When transmitting data from A-ports to B-ports, during a rising edge the one-shot circuit (OS3) turns on the PMOS transistor (P2) for a short-duration which reduces the low-to-high transition time. Similarly, during a falling edge, when transmitting data from A to B, the one-shot circuit (OS4) turns on the N-channel MOSFET transistor (N2) for a short-duration which speeds up the high-to-low transition. The B-port edge-rate accelerator consists of one-shot circuits OS3 and OS4, transistors P2 and N2 and serves to rapidly force the B port high or low when a corresponding transition is detected on the A port.

When transmitting data from B- to A-ports, during a rising edge the one-shot circuit (OS1) turns on the PMOS transistor (P1) for a short-duration which reduces the low-to-high transition time. Similarly, during a falling edge, when transmitting data from B to A, the one-shot circuit (OS2) turns on NMOS transistor (N1) for a short-duration and this speeds up the high-to-low transition. The A-port edge-rate accelerator consists of one-shots OS1 and OS2, transistors P1 and N1 components and form the edge-rate accelerator and serves to rapidly force the A port high or low when a corresponding transition is detected on the B port.



### 9.3.2 Input Driver Requirements

The continuous DC-current *sinking* capability is determined by the external system-level open-drain (or push-pull) drivers that are interfaced to the TXS0108E-Q1 I/O pins. Because the high bandwidth of these bidirectional I/O circuits is used to facilitate this fast change from an input to an output and an output to an input, they have a modest DC-current *sourcing* capability of hundreds of micro-amperes, as determined by the internal pull-up resistors.

The fall time ( $t_{fA}$ ,  $t_{fB}$ ) of a signal depends on the edge-rate and output impedance of the external device driving TXS0108E-Q1 data I/Os, as well as the capacitive loading on the data lines.

Similarly, the  $t_{PHL}$  and maximum data rates also depend on the output impedance of the external driver. The values for  $t_{fA}$ ,  $t_{fB}$ ,  $t_{PHL}$ , and maximum data rates in the data sheet assume that the output impedance of the external driver is less than 50  $\Omega$ .

### 9.3.3 Output Load Considerations

TI recommends careful PCB layout practices with short PCB trace lengths to avoid excessive capacitive loading and to ensure that proper one-shot triggering takes place. PCB signal trace-lengths should be kept short enough such that the round trip delay of any reflection is less than the one-shot duration. This improves signal integrity by ensuring that any reflection sees a low impedance at the driver. The one-shot circuits have been designed to stay on for approximately 30 ns. The maximum capacitance of the lumped load that can be driven also depends directly on the one-shot duration. With very heavy capacitive loads, the one-shot can time-out before the signal is driven fully to the positive rail. The one-shot duration has been set to best optimize trade-offs between dynamic  $I_{CC}$ , load driving capability, and maximum bit-rate considerations. Both PCB trace length and connectors add to the capacitance of the TXS0108E-Q1 output. Therefore, TI recommends that this lumped-load capacitance is considered in order to avoid one-shot retriggering, bus contention, output signal oscillations, or other adverse system-level affects.

### 9.3.4 Enable and Disable

The TXS0108E-Q1 has an OE pin input that is used to disable the device by setting the OE pin low, which places all I/Os in the Hi-Z state. The disable time ( $t_{dis}$ ) indicates the delay between the time when the OE pin goes low and when the outputs actually get disabled (Hi-Z). The enable time ( $t_{en}$ ) indicates the amount of time the design must allow for the one-shot circuitry to become operational after the OE pin goes high.

### 9.3.5 Pull-up or Pull-down Resistors on I/O Lines

The TXS0108E-Q1 has the smart pull-up resistors dynamically change value based on whether a low or a high is being passed through the I/O line. Each A-port I/O has a pull-up resistor ( $R_{PUA}$ ) to  $V_{CCA}$  and each B-port I/O has a pull-up resistor ( $R_{PUB}$ ) to  $V_{CCB}$ .  $R_{PUA}$  and  $R_{PUB}$  have a value of 40 k $\Omega$  when the output is driving low.  $R_{PUA}$  and  $R_{PUB}$  have a value of 4 k $\Omega$  when the output is driving high.  $R_{PUA}$  and  $R_{PUB}$  are disabled when OE = Low. This feature provides lower static power consumption (when the I/Os are passing a low), and supports lower  $V_{OL}$  values for the same size pass-gate transistor, and helps improve simultaneous switching performance.

## 9.4 Device Functional Modes

The TXS0108E-Q1 device has two functional modes, enabled and disabled. To disable the device set the OE pin input low, which places all I/Os in a high impedance state. Setting the OE pin input high enables the device.

## 10 Application and Implementation

### Note

Information in the following applications sections is not part of the TI component specification, and TI does not warrant its accuracy or completeness. TI's customers are responsible for determining suitability of components for their purposes. Customers should validate and test their design implementation to confirm system functionality.

### 10.1 Application Information

The TXS0108E-Q1 can be used in level-translation applications for interfacing devices or systems operating at different interface voltages with one another. The device is ideal for use in applications where an open-drain driver is connected to the data I/Os. The device is appropriate for applications where a push-pull driver is connected to the data I/Os, but the TXB0104 device, ([SCES650](#)) *4-Bit Bidirectional Voltage-Level Translator* might be a better option for such push-pull applications. The device is a semi-buffered auto-direction-sensing voltage translator design is optimized for translation applications (for example, MMC Card Interfaces) that require the system to start out in a low-speed open-drain mode and then switch to a higher speed push-pull mode.

### 10.2 Typical Application

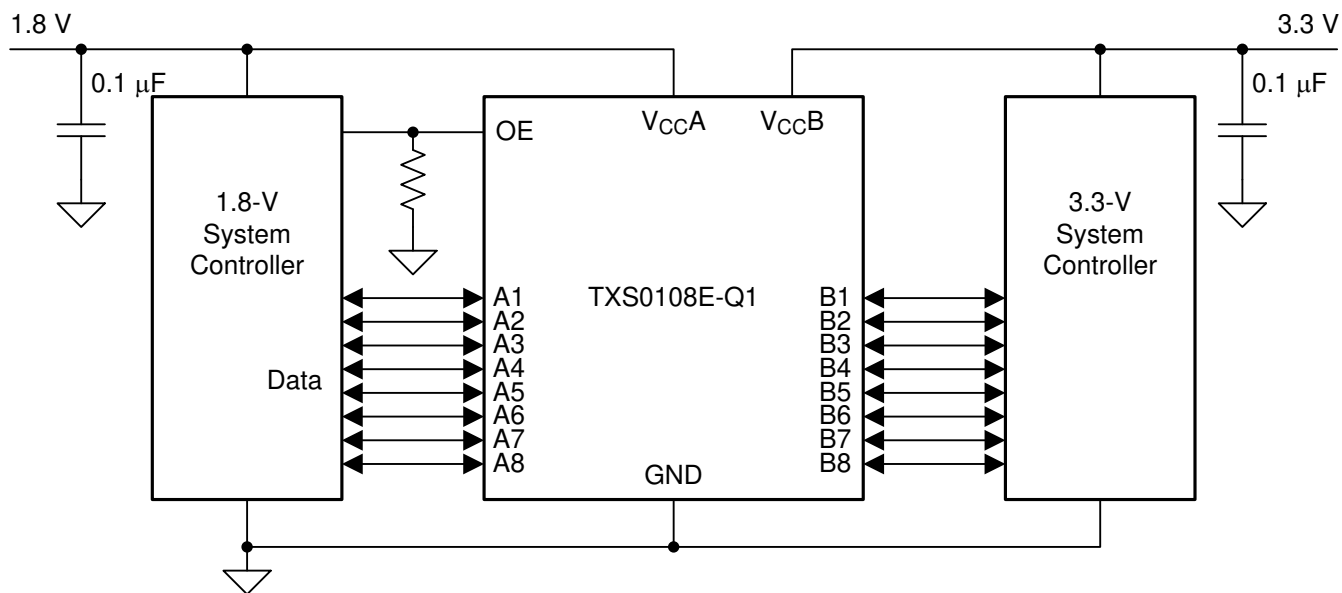

Figure 10-1. Typical Application Circuit

#### 10.2.1 Design Requirements

For this design example, use the parameters listed in [Table 10-1](#). Ensure that  $V_{CCA} \leq V_{CCB}$ .

Table 10-1. Design Parameters

DESIGN PARAMETER	EXAMPLE VALUE
Input voltage range	1.4 V to 3.6 V
Output voltage range	1.65 V to 5.5 V

#### 10.2.2 Detailed Design Procedure

To begin the design process, determine the following:

- Input voltage range

- Use the supply voltage of the device that is driving the TXS0108E-Q1 device to determine the input voltage range. For a valid logic high the value must exceed the  $V_{IH}$  of the input port. For a valid logic low the value must be less than the  $V_{IL}$  of the input port.
- Output voltage range
  - Use the supply voltage of the device that the TXS0108E-Q1 device is driving to determine the output voltage range.
  - The TXS0108E-Q1 device has smart internal pull-up resistors. External pull-up resistors can be added to reduce the total RC of a signal trace if necessary.
- An external pull-down resistor decreases the output  $V_{OH}$  and  $V_{OL}$ . Use Equation 1 to calculate the  $V_{OH}$  as a result of an external pull-down resistor.

$$V_{OH} = V_{CCx} \times R_{PD} / (R_{PD} + 4 \text{ k}\Omega) \quad (1)$$

### 10.2.3 Application Curves

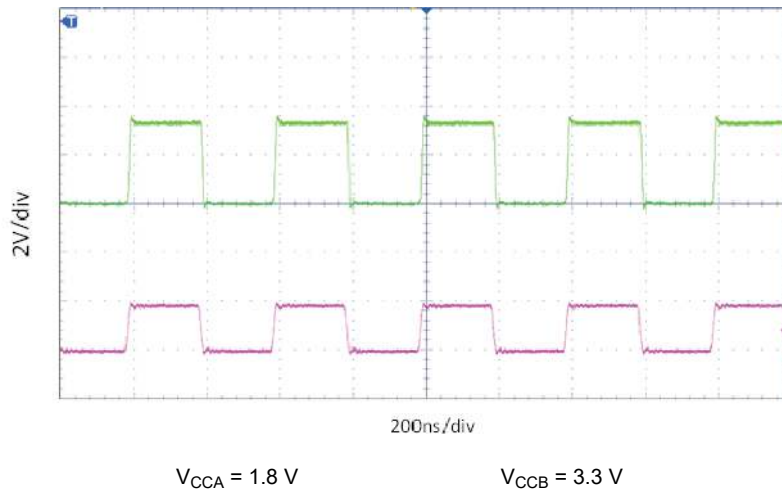

**Figure 10-2. Level-Translation of a 2.5-MHz Signal**

## 10.3 Power Supply Recommendations

During operation, ensure that  $V_{CCA} \leq V_{CCB}$  at all times. The sequencing of each power supply will not damage the device during the power up operation, so either power supply can be ramped up first. The output-enable (OE) input circuit is designed so that it is supplied by  $V_{CCA}$  and when the (OE) input is low, all outputs are placed in the high-impedance state. To ensure the high-impedance state of the outputs during power up or power down, the OE input pin must be tied to GND through a pull-down resistor and must not be enabled until  $V_{CCA}$  and  $V_{CCB}$  are fully ramped and stable. The minimum value of the pull-down resistor to ground is determined by the current-sourcing capability of the driver.

## 10.4 Layout

### 10.4.1 Layout Guidelines

To ensure reliability of the device, following common printed-circuit board layout guidelines is recommended.

- Bypass capacitors should be used on power supplies. Place the capacitors as close as possible to the  $V_{CCA}$ ,  $V_{CCB}$  pin and GND pin.
- Short trace lengths should be used to avoid excessive loading.
- PCB signal trace-lengths must be kept short enough so that the round-trip delay of any reflection is less than the one shot duration, approximately 30 ns, ensuring that any reflection encounters low impedance at the source driver.

### 10.4.2 Layout Example

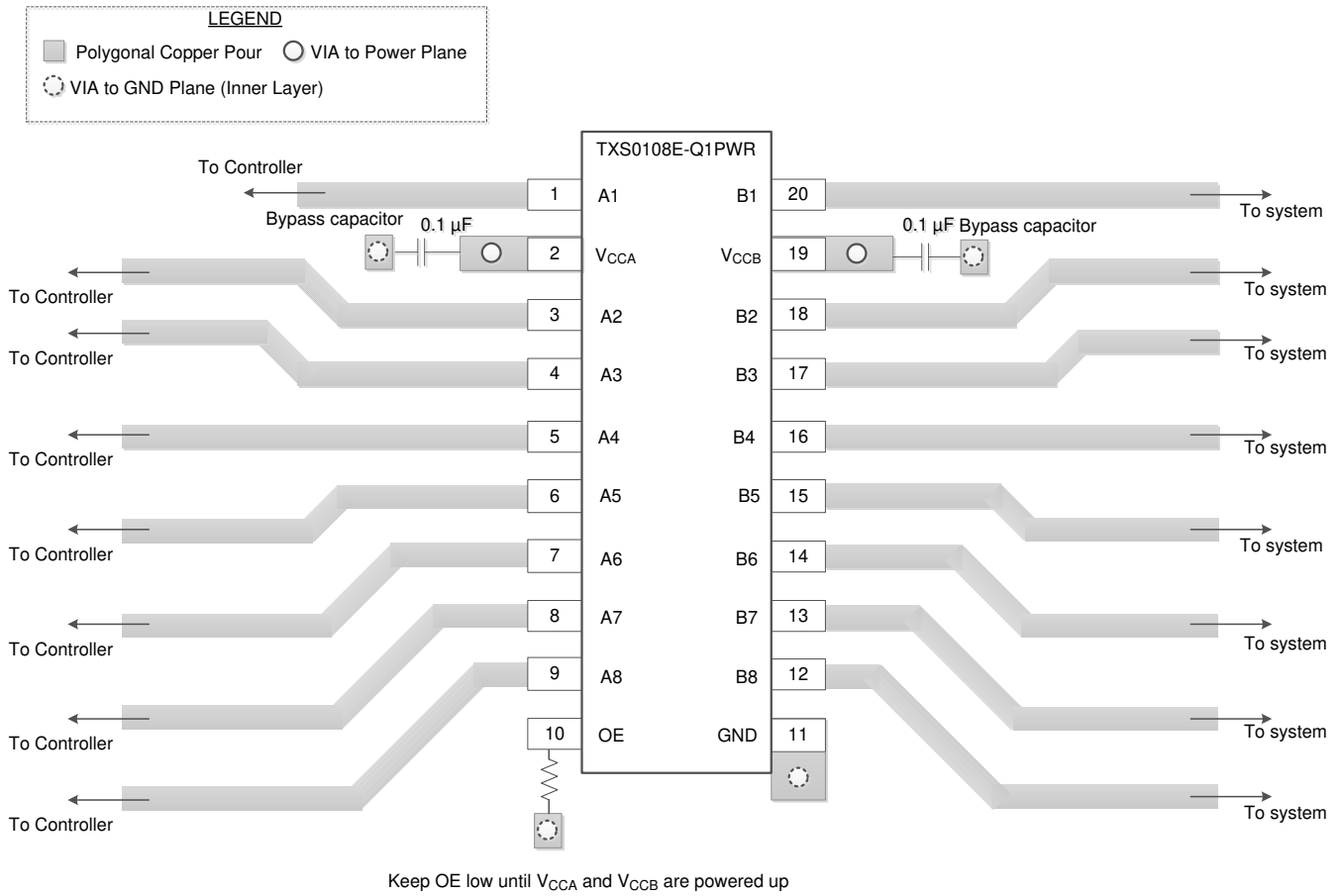

**Figure 10-3. Layout Example**

## 11 Device and Documentation Support

### 11.1 Receiving Notification of Documentation Updates

To receive notification of documentation updates, navigate to the device product folder on [ti.com](http://ti.com). Click on *Subscribe to updates* to register and receive a weekly digest of any product information that has changed. For change details, review the revision history included in any revised document.

### 11.2 Support Resources

TI E2E™ [support forums](#) are an engineer's go-to source for fast, verified answers and design help — straight from the experts. Search existing answers or ask your own question to get the quick design help you need.

Linked content is provided "AS IS" by the respective contributors. They do not constitute TI specifications and do not necessarily reflect TI's views; see TI's [Terms of Use](#).

1. Texas Instruments, Application Note, [A guide to Voltage level translation using TXS devices](#)
2. Texas Instruments, Application Note, [Factors affecting the Vol of TXS AutoBidirectional Devices](#)
3. Texas Instruments, Application Note, [Effects of Pullup and Pulldown resistors on TXS Devices](#)

### 11.3 Trademarks

TI E2E™ is a trademark of Texas Instruments.  
All trademarks are the property of their respective owners.

### 11.4 Electrostatic Discharge Caution



This integrated circuit can be damaged by ESD. Texas Instruments recommends that all integrated circuits be handled with appropriate precautions. Failure to observe proper handling and installation procedures can cause damage.

ESD damage can range from subtle performance degradation to complete device failure. Precision integrated circuits may be more susceptible to damage because very small parametric changes could cause the device not to meet its published specifications.

### 11.5 Glossary

[TI Glossary](#) This glossary lists and explains terms, acronyms, and definitions.

## 12 Mechanical, Packaging, and Orderable Information

The following pages include mechanical, packaging, and orderable information. This information is the most current data available for the designated devices. This data is subject to change without notice and revision of this document. For browser-based versions of this data sheet, refer to the left-hand navigation.

**PACKAGING INFORMATION**

Orderable Device	Status (1)	Package Type	Package Drawing	Pins	Package Qty	Eco Plan (2)	Lead finish/ Ball material (6)	MSL Peak Temp (3)	Op Temp (°C)	Device Marking (4/5)	Samples
TXS0108EQPWRQ1	ACTIVE	TSSOP	PW	20	2000	RoHS & Green	NIPDAU	Level-1-260C-UNLIM	-40 to 125	YF08EQ1	Samples

(1) The marketing status values are defined as follows:

**ACTIVE:** Product device recommended for new designs.

**LIFEBUY:** TI has announced that the device will be discontinued, and a lifetime-buy period is in effect.

**NRND:** Not recommended for new designs. Device is in production to support existing customers, but TI does not recommend using this part in a new design.

**PREVIEW:** Device has been announced but is not in production. Samples may or may not be available.

**OBSELETE:** TI has discontinued the production of the device.

(2) **RoHS:** TI defines "RoHS" to mean semiconductor products that are compliant with the current EU RoHS requirements for all 10 RoHS substances, including the requirement that RoHS substance do not exceed 0.1% by weight in homogeneous materials. Where designed to be soldered at high temperatures, "RoHS" products are suitable for use in specified lead-free processes. TI may reference these types of products as "Pb-Free".

**RoHS Exempt:** TI defines "RoHS Exempt" to mean products that contain lead but are compliant with EU RoHS pursuant to a specific EU RoHS exemption.

**Green:** TI defines "Green" to mean the content of Chlorine (Cl) and Bromine (Br) based flame retardants meet JS709B low halogen requirements of <=1000ppm threshold. Antimony trioxide based flame retardants must also meet the <=1000ppm threshold requirement.

(3) MSL, Peak Temp. - The Moisture Sensitivity Level rating according to the JEDEC industry standard classifications, and peak solder temperature.

(4) There may be additional marking, which relates to the logo, the lot trace code information, or the environmental category on the device.

(5) Multiple Device Markings will be inside parentheses. Only one Device Marking contained in parentheses and separated by a "-" will appear on a device. If a line is indented then it is a continuation of the previous line and the two combined represent the entire Device Marking for that device.

(6) Lead finish/Ball material - Orderable Devices may have multiple material finish options. Finish options are separated by a vertical ruled line. Lead finish/Ball material values may wrap to two lines if the finish value exceeds the maximum column width.

**Important Information and Disclaimer:**The information provided on this page represents TI's knowledge and belief as of the date that it is provided. TI bases its knowledge and belief on information provided by third parties, and makes no representation or warranty as to the accuracy of such information. Efforts are underway to better integrate information from third parties. TI has taken and continues to take reasonable steps to provide representative and accurate information but may not have conducted destructive testing or chemical analysis on incoming materials and chemicals. TI and TI suppliers consider certain information to be proprietary, and thus CAS numbers and other limited information may not be available for release.

In no event shall TI's liability arising out of such information exceed the total purchase price of the TI part(s) at issue in this document sold by TI to Customer on an annual basis.

**OTHER QUALIFIED VERSIONS OF TXS0108E-Q1 :**

- Catalog : [TXS0108E](#)

NOTE: Qualified Version Definitions:

- Catalog - TI's standard catalog product

**TAPE AND REEL INFORMATION**

**QUADRANT ASSIGNMENTS FOR PIN 1 ORIENTATION IN TAPE**

\*All dimensions are nominal

Device	Package Type	Package Drawing	Pins	SPQ	Reel Diameter (mm)	Reel Width W1 (mm)	A0 (mm)	B0 (mm)	K0 (mm)	P1 (mm)	W (mm)	Pin1 Quadrant
TXS0108EQPWRQ1	TSSOP	PW	20	2000	330.0	16.4	6.95	7.0	1.4	8.0	16.0	Q1



**TAPE AND REEL BOX DIMENSIONS**

\*All dimensions are nominal

Device	Package Type	Package Drawing	Pins	SPQ	Length (mm)	Width (mm)	Height (mm)
TXS0108EQPWRQ1	TSSOP	PW	20	2000	356.0	356.0	35.0

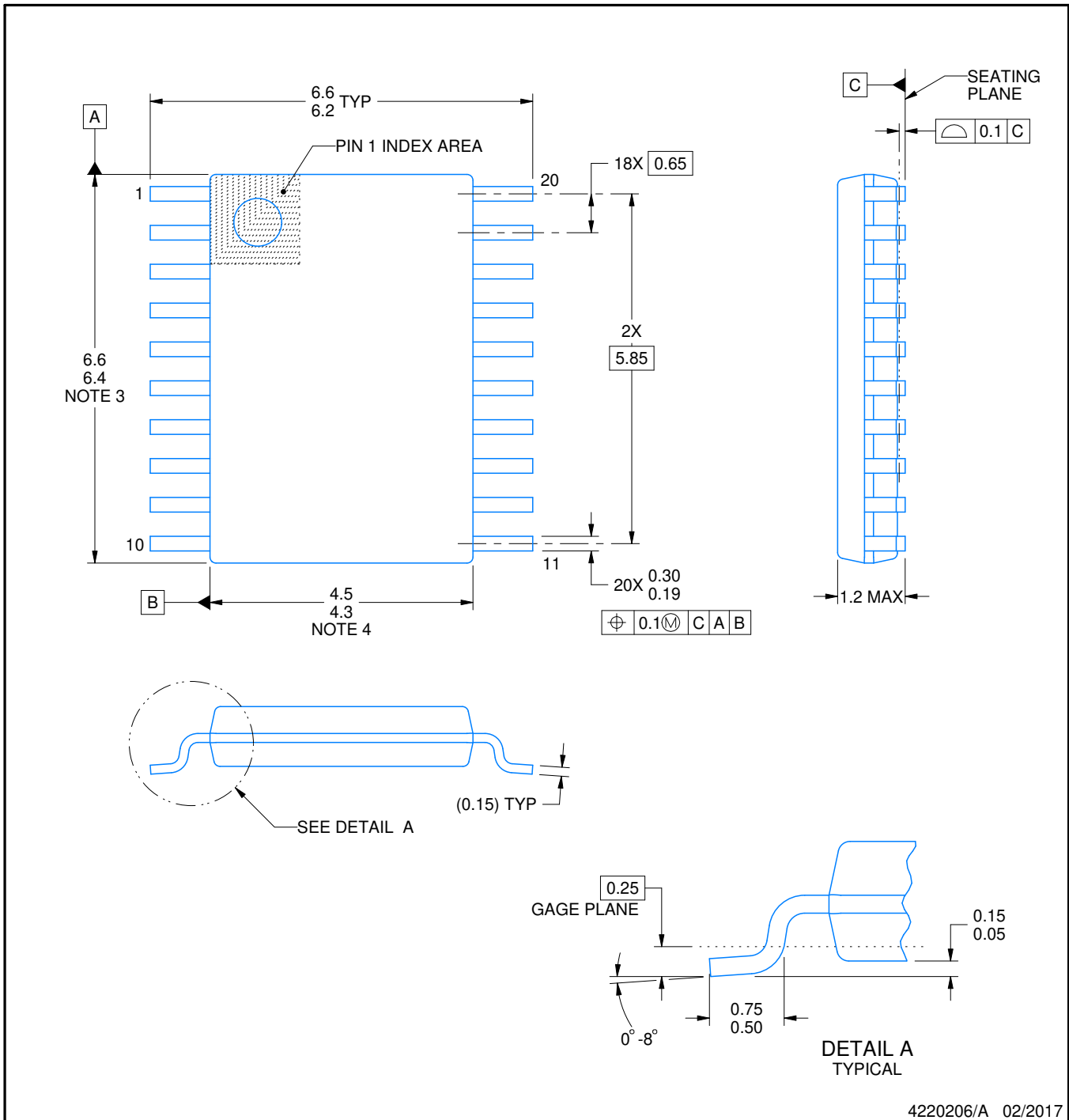

4220206/A 02/2017

NOTES:

1. All linear dimensions are in millimeters. Any dimensions in parenthesis are for reference only. Dimensioning and tolerancing per ASME Y14.5M.
2. This drawing is subject to change without notice.
3. This dimension does not include mold flash, protrusions, or gate burrs. Mold flash, protrusions, or gate burrs shall not exceed 0.15 mm per side.
4. This dimension does not include interlead flash. Interlead flash shall not exceed 0.25 mm per side.
5. Reference JEDEC registration MO-153.

# EXAMPLE BOARD LAYOUT

PW0020A

TSSOP - 1.2 mm max height

SMALL OUTLINE PACKAGE

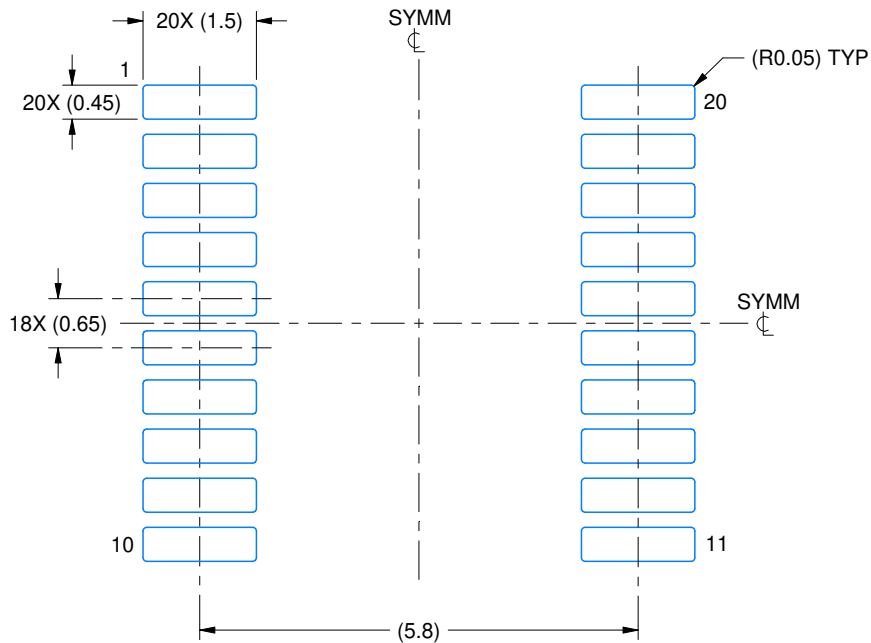

LAND PATTERN EXAMPLE  
EXPOSED METAL SHOWN  
SCALE: 10X



4220206/A 02/2017

NOTES: (continued)

- 6. Publication IPC-7351 may have alternate designs.
- 7. Solder mask tolerances between and around signal pads can vary based on board fabrication site.

# EXAMPLE STENCIL DESIGN

PW0020A

TSSOP - 1.2 mm max height

SMALL OUTLINE PACKAGE

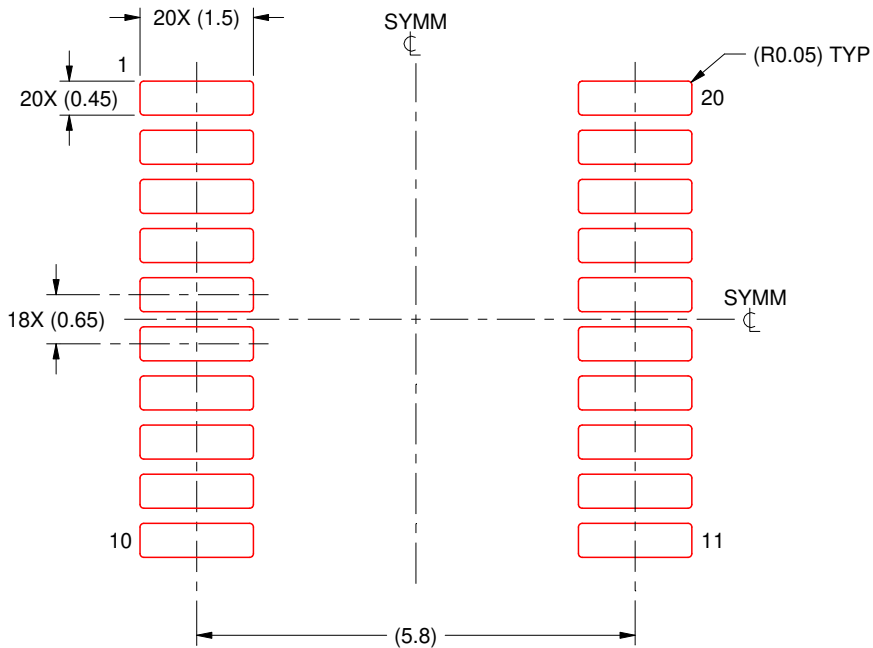

SOLDER PASTE EXAMPLE  
BASED ON 0.125 mm THICK STENCIL  
SCALE: 10X

4220206/A 02/2017

NOTES: (continued)

8. Laser cutting apertures with trapezoidal walls and rounded corners may offer better paste release. IPC-7525 may have alternate design recommendations.
9. Board assembly site may have different recommendations for stencil design.

PW (R-PDSO-G20)

PLASTIC SMALL OUTLINE

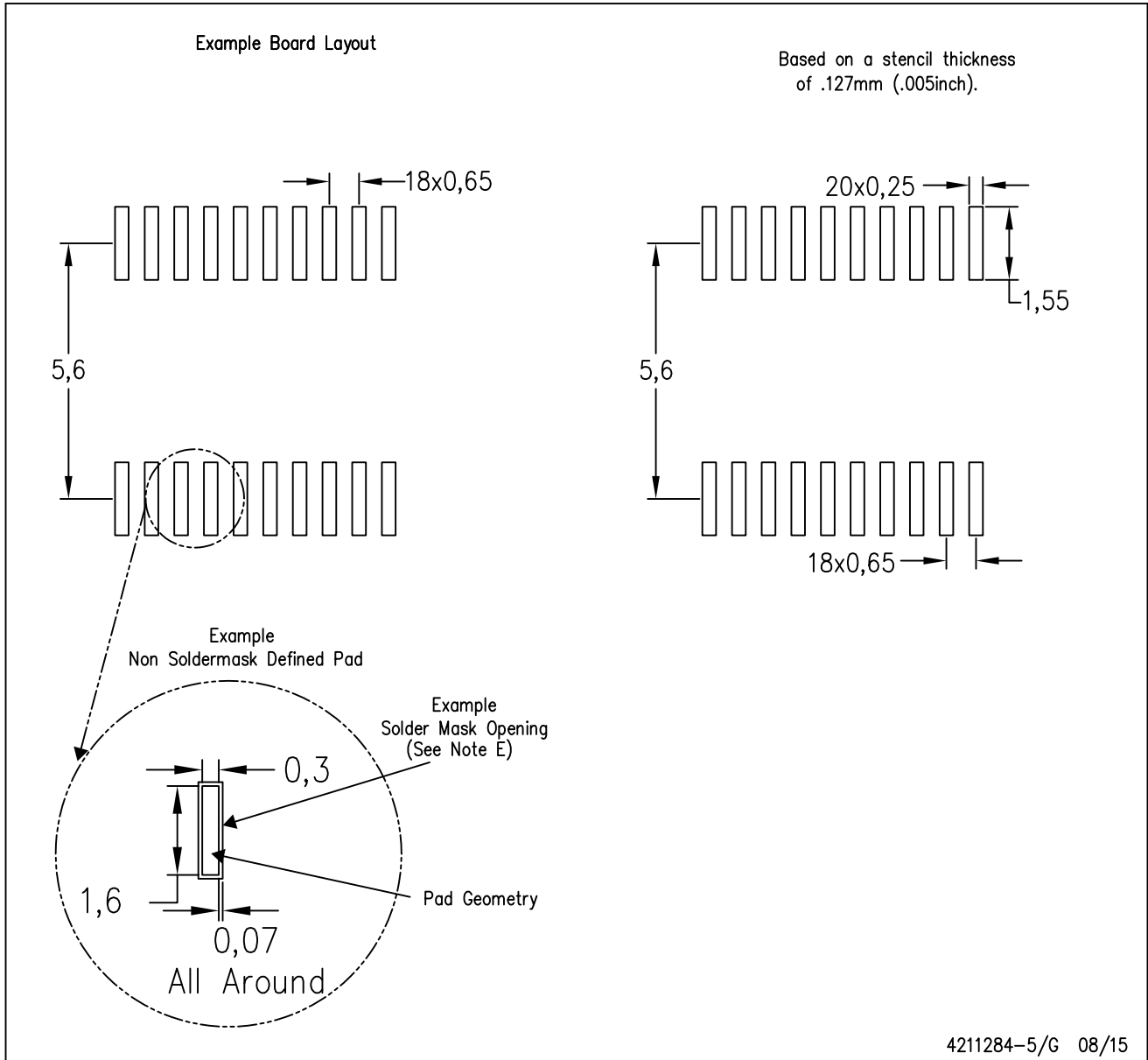

- NOTES:
- A. All linear dimensions are in millimeters.
  - B. This drawing is subject to change without notice.
  - C. Publication IPC-7351 is recommended for alternate design.
  - D. Laser cutting apertures with trapezoidal walls and also rounding corners will offer better paste release. Customers should contact their board assembly site for stencil design recommendations. Refer to IPC-7525 for other stencil recommendations.
  - E. Customers should contact their board fabrication site for solder mask tolerances between and around signal pads.

## IMPORTANT NOTICE AND DISCLAIMER

TI PROVIDES TECHNICAL AND RELIABILITY DATA (INCLUDING DATA SHEETS), DESIGN RESOURCES (INCLUDING REFERENCE DESIGNS), APPLICATION OR OTHER DESIGN ADVICE, WEB TOOLS, SAFETY INFORMATION, AND OTHER RESOURCES "AS IS" AND WITH ALL FAULTS, AND DISCLAIMS ALL WARRANTIES, EXPRESS AND IMPLIED, INCLUDING WITHOUT LIMITATION ANY IMPLIED WARRANTIES OF MERCHANTABILITY, FITNESS FOR A PARTICULAR PURPOSE OR NON-INFRINGEMENT OF THIRD PARTY INTELLECTUAL PROPERTY RIGHTS.

These resources are intended for skilled developers designing with TI products. You are solely responsible for (1) selecting the appropriate TI products for your application, (2) designing, validating and testing your application, and (3) ensuring your application meets applicable standards, and any other safety, security, regulatory or other requirements.

These resources are subject to change without notice. TI grants you permission to use these resources only for development of an application that uses the TI products described in the resource. Other reproduction and display of these resources is prohibited. No license is granted to any other TI intellectual property right or to any third party intellectual property right. TI disclaims responsibility for, and you will fully indemnify TI and its representatives against, any claims, damages, costs, losses, and liabilities arising out of your use of these resources.

TI's products are provided subject to [TI's Terms of Sale](#) or other applicable terms available either on [ti.com](https://www.ti.com) or provided in conjunction with such TI products. TI's provision of these resources does not expand or otherwise alter TI's applicable warranties or warranty disclaimers for TI products.

TI objects to and rejects any additional or different terms you may have proposed.

Mailing Address: Texas Instruments, Post Office Box 655303, Dallas, Texas 75265  
Copyright © 2023, Texas Instruments Incorporated