

4

3

2

1

THIS DRAWING IS UNPUBLISHED. RELEASED FOR PUBLICATION
 © COPYRIGHT - TE Connectivity Ltd. ALL RIGHTS RESERVED.

REVISIONS					
P	LTR	DESCRIPTION	DATE	DWN	APVD
	O	RELEASED PER 0720-008-93	3-1-93	-	DAP
	A	REVISED PER ECO-18-013301	23AUG2018	RS	DR

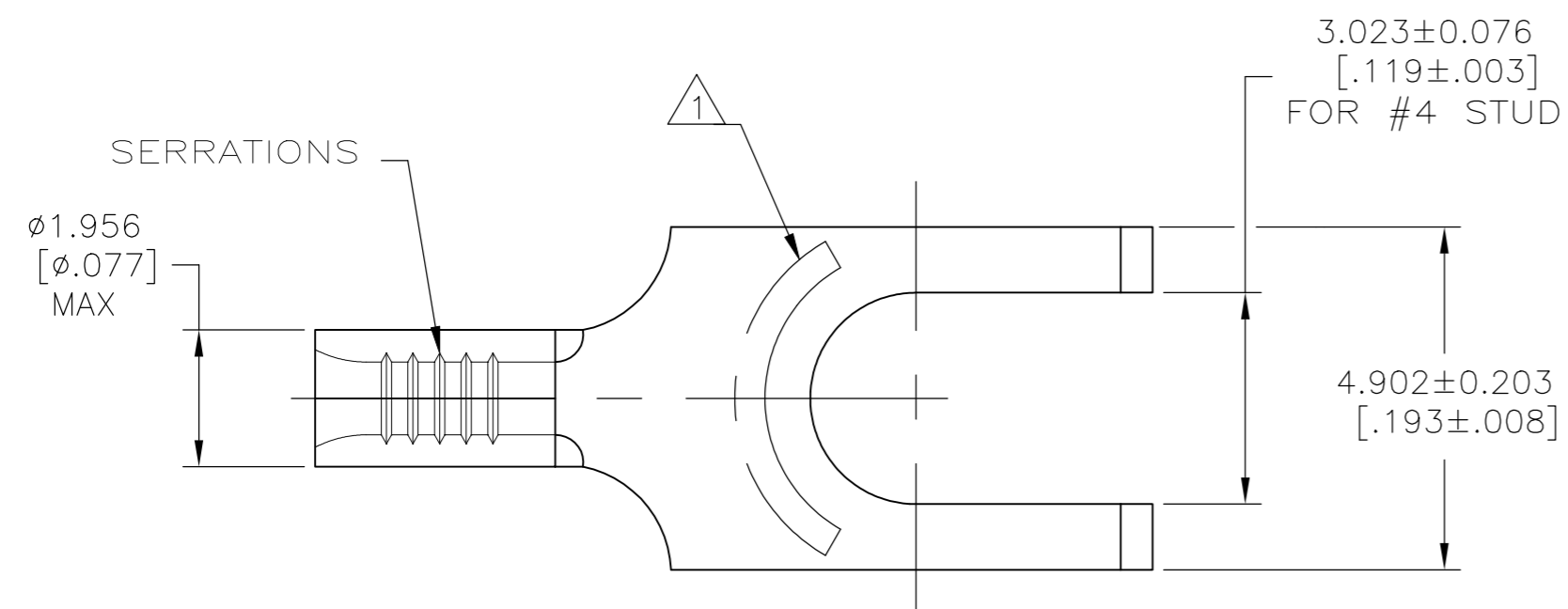

AMP
 WIRE RANGE
 26-22 AWG
 STRANDED

△ 1 STAMP AMP APPROX AS SHOWN

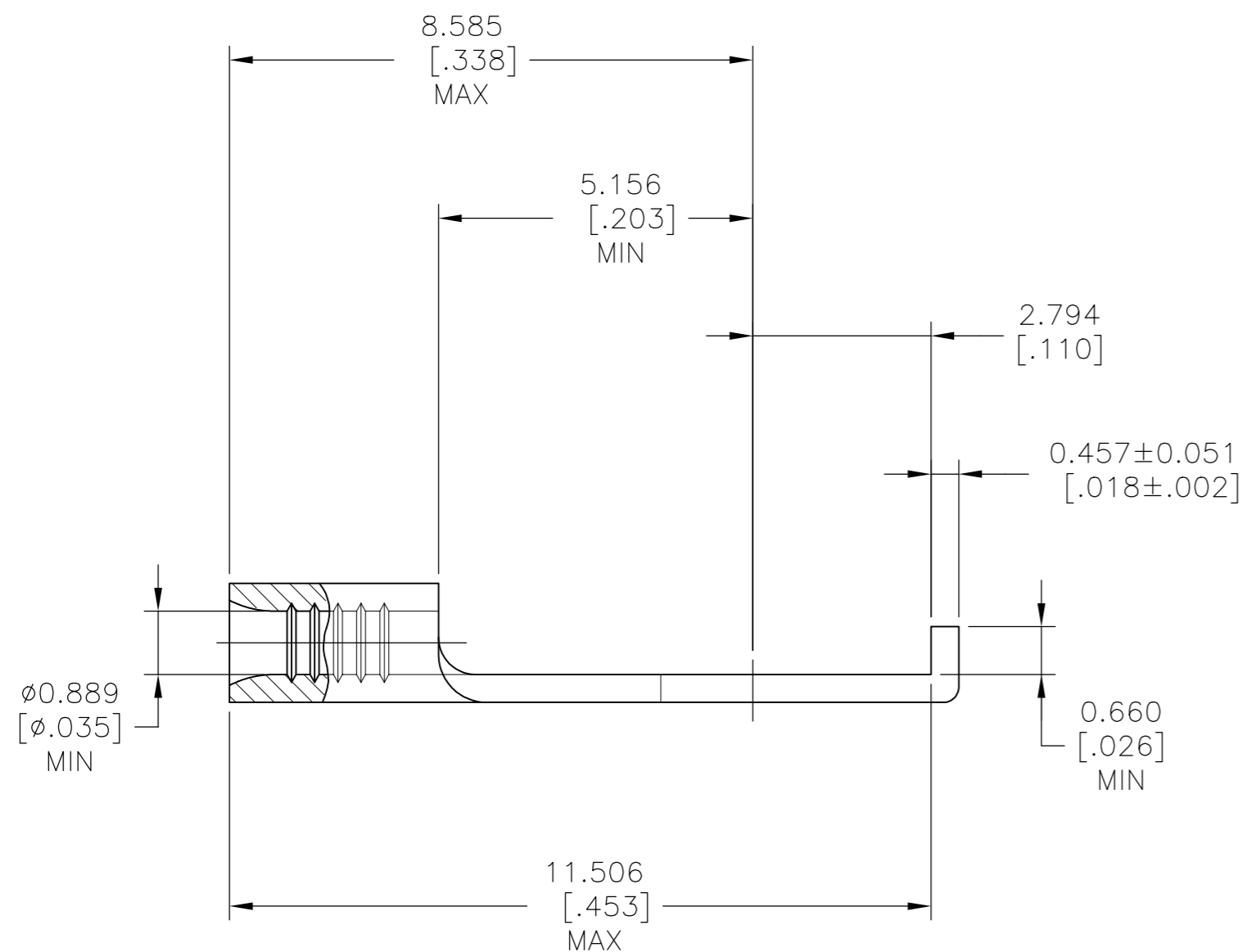

1000	LOOSE PIECE	52512-1
QTY	PACKAGE TYPE	PART NO

AMP INCORPORATED CUSTOMER SERVICE SYSTEMS		
FOR ADDITIONAL PRODUCT INFORMATION OR COPIES OF DRAWINGS AND TECHNICAL DOCUMENTS	PRODUCT INFORMATION CENTER 1-800-522-6752	MAX RECOMMENDED OPERATING TEMPERATURE: 170°C [338°F] MAX
FOR APPLICATION TOOLING INFORMATION	TOOLING ASSISTANCE CENTER 1-800-722-1111	VOLTAGE RATING: NOT APPLICABLE
FOR ORDER ENTRY	1-800-526-5142	WIRE CROSS SECTIONAL AREA RANGE, 0.1-0.41mm² [202-810] CIR MILS STRANDED

THIS DRAWING IS A CONTROLLED DOCUMENT.		DWN TA BRINKMAN 3-1-93	1000		LOOSE PIECE	52512-1
DIMENSIONS: mm [INCHES]		CHK DA PATTERSON 3-1-93	QTY		PACKAGE TYPE	PART NO
TOLERANCES UNLESS OTHERWISE SPECIFIED: 0 PLC ± - 1 PLC ± - 2 PLC ± - 3 PLC ± 0.127[.005] 4 PLC ± -		APVD DE MILLER 3-1-93	TE Connectivity Ltd.			
MATERIAL COPPER PER ASTM B-152 ANNEALED		FINISH TIN PLATE 0.00254[.000100] MIN THK PER ASTM B545	NAME TERMINAL, FLANGED SPADE, BUDGET 26-22 AWG		RESTRICTED TO	
WEIGHT		SIZE A2	CAGE CODE 00779	DRAWING NO C=52512	SCALE 10:1	
CUSTOMER DRAWING		SHEET 1 of 1		REV A		