

CONFIDENTIAL. THE INFORMATION CONTAINED IN THIS DOCUMENT IS THE PROPERTY OF COOPER INDUSTRIES, INC. IT IS NOT FOR PUBLIC DISCLOSURE. POSSESSION OF THE INFORMATION DOES NOT CONVEY ANY RIGHT TO LOAN, SELL OR DISCLOSE THE INFORMATION. UNAUTHORIZED REPRODUCTION OR USE OF THE INFORMATION IS PROHIBITED. THIS DOCUMENT IS TO BE RETURNED TO COOPER INDUSTRIES, INC. UPON COMPLETION OF THE PURPOSE FOR WHICH IT IS LOANED OR UPON REQUEST.

COPYRIGHT Cooper Industries, Inc.
This is an unpublished work. The disclosure of this work is limited to select personnel. Further dissemination or disclosure to the public is PROHIBITED. This unpublished work is protected by Federal Copyright law and all rights thereunder are reserved by Cooper Industries, Inc.

SCALE
1x

UNLESS OTHERWISE SPECIFIED TOLERANCES TO BE:
METRIC $\pm .13\text{mm}$
INCHES $\pm .005''$
ANGULAR $\pm 2^\circ$

(O)
INDICATES CRITICAL DIMENSION OR FEATURE

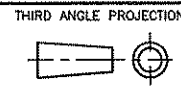

THIRD ANGLE PROJECTION

INCHES (OR U.S. UNITS) IS THE PRIMARY UNIT OF MEASURE
METRIC(mm)
[INCHES]

DATE	NO.	
1-2-04	4164-SM	
TITLE		
FUSEBLOCK		
SUP. NO.	DATED	
4164-SM	4-28-03	
DWG.	CK.	REV.
DAG		C
PAGE 1 OF 2		N03069
COOPER Bussmann		
St. Louis, MO 63178		
C/F NO.	DISTRIBUTION	
55842		56 J

CUSTOMER PRINT

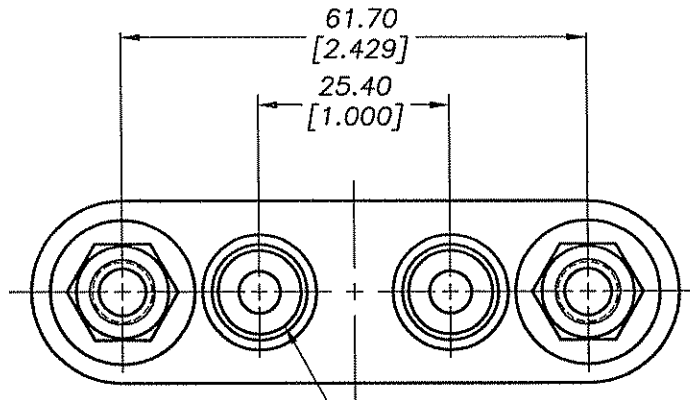

11.10 DIA. x 82° COUNTERSINK
[.437]
AND 5.59 DIA. THRU HOLE (2 PLACES)
[.220]

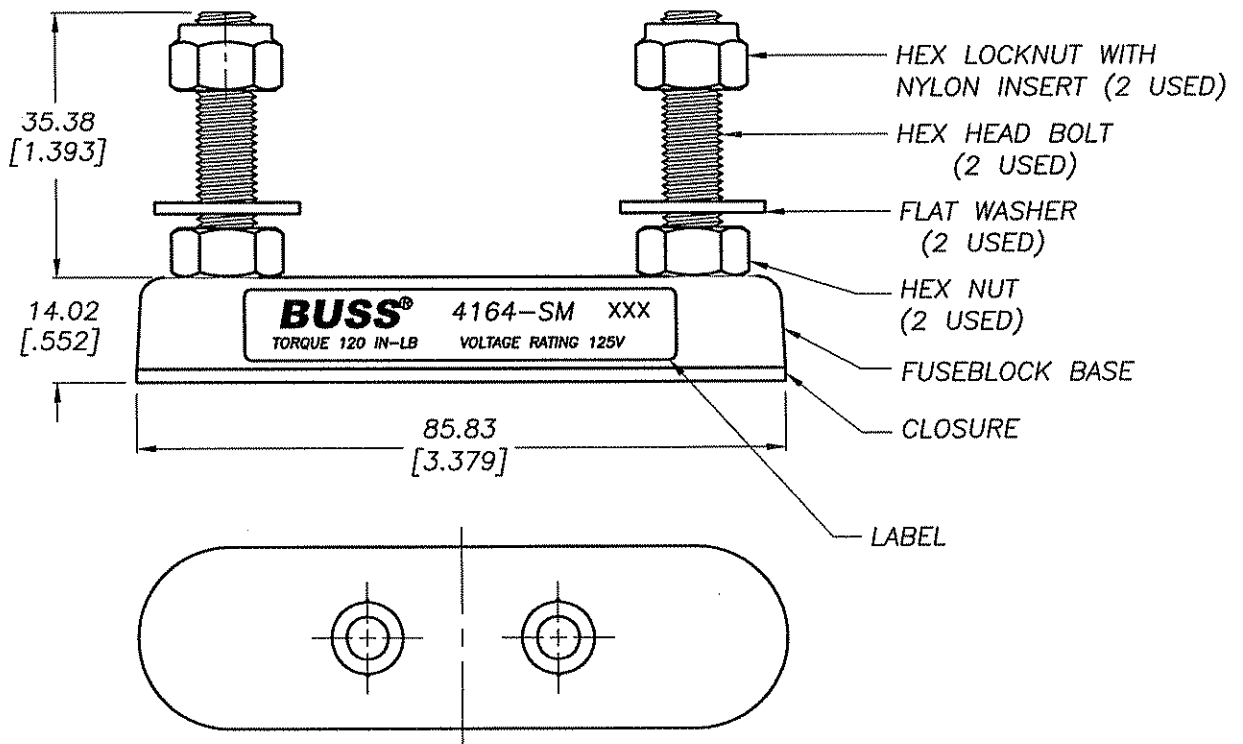

NOTE: ALL HARDWARE IS METRIC, SIZE M8, ZINC PLATED STEEL.