

Transfer or duplication of this document as well as the utilisation or communication of its content are not permitted unless express consent is granted. Violations give rise to claims for damages. All rights reserved in case of patent, utility model or design patent registrations.

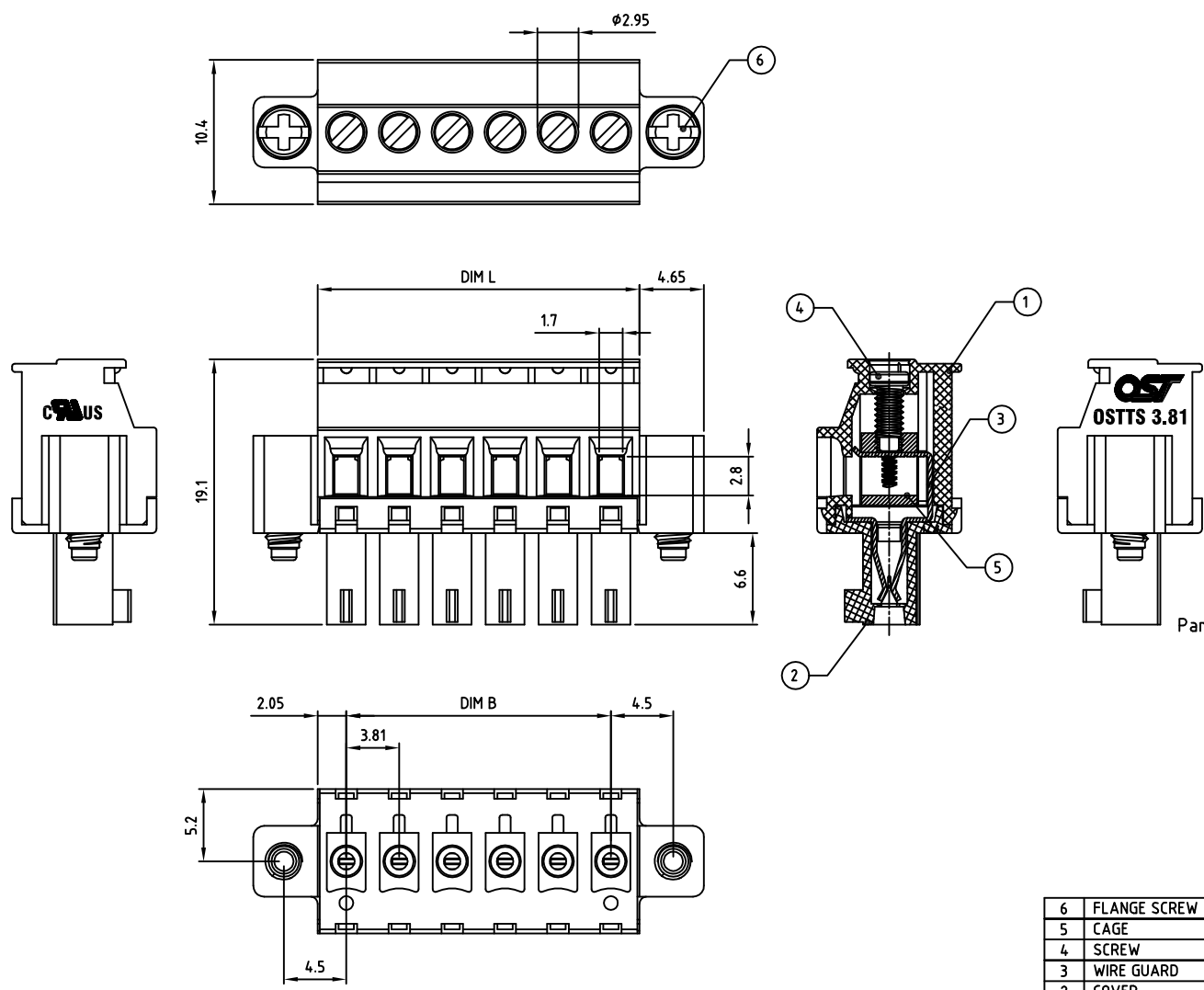

- Technical data**
- Nominal voltage: 300V/8A
PITCH:3.81mm
 - Connection capacity:
AWG 30-16
 - Insulation Withstanding Voltage:
AC 1600V/MIN
 - Insulation Resistance:
1000MΩ or more at DC500V
 - Tightening torque:
2.3kgf.cm (2 Lb-in / 0.23N.m)
 - Screw thread: M2
 - Stripping length: 6-7mm
 - Operating temperature range:-40°C ~ 115°C
 - Undimensioned Tolerances:

Dim.L=Px3.81+0.3 Dim.B=(P-1)x3.81 P= number of poles		
0-30mm	Dim B ±0.15	Dim L ±0.20
over 30mm-60mm	±0.20	±0.25
over 60mm-90mm	±0.25	±0.30
over 90mm	±0.30	±0.40

- Safety approval:
- RoHS Compliance

Part No.:

OSTTSXX315C

No. of Poles	COLOR
02 2 Poles	0: Black
03 3 Poles	2: Red
...	3: Orange
24 24 Poles	4: Yellow
	5: Green (Standard)
	6: Blue
Nonstandard colors Mins could apply	8: Grey

6	FLANGE SCREW	STEEL	M2.5x0.45, Zn Plated	2
5	CAGE	BRASS	M2.0x0.4, Ni PLATED	P
4	SCREW	STEEL	M2.0x0.4, Zn Plated	P
3	WIRE GUARD	BRONZE (PhBz)	TIN PLATED	P
2	COVER	PA66 UL94V-0	ALL COLOR	1
1	BODY	PA66 UL94V-0	ALL COLOR	1
ITEM	NAME OF PART	MATERIAL	NOTES	Q'TY
DWG.	WF. Zhang	DATE	2016.05.28	UNITS: MM SHEET: 1 OF 1 Tolerance
CHK.	WF. Zhang	DATE	2016.06.21	SCALE: NONE 2.5:1 (:) REV.: A
APP.		DATE		TITLE: OSTTS 3.81 Series W/Flange "- " Slot screw type
				PART NO. OSTTSXX315C
				DWG NO. OSTTSXX315C.dwg

	SIGN	DESCRIPTION	CHK.	DATE
--	------	-------------	------	------



ON-SHORE TECHNOLOGY, INC.